	E480232
---	----------------

Features

- AEC-Q101 Qualified
- For Surface Mount Applications
- Excellent Clamping Capability
- High Temp Soldering: 260°C / 10 Seconds at Terminals
- Halogen Free. "Green" Device (Note 1)
- Moisture Sensitivity Level 1
- Epoxy Meets UL 94 V-0 Flammability Rating
- Lead Free Finish/RoHS Compliant (Note 2) ("P" Suffix Designates RoHS Compliant. See Ordering Information)
- ESD protection of data lines in accordance with IEC 61000-4-2, 30kV(Air), 30kV (Contact)



Maximum Ratings

Parameter	Symbol	Value	Unit
Peak Pulse Power Surge Current with a 10/1000µs Waveform (Note 3)	I_{PPM}	See Next Table	A
Peak Pulse Power Dissipation (Note 3)	P_{PPM}	5000	W
Power Dissipation infinite heat sink at $T_L = 75^\circ$	P_D	6.5	W
Peak Forward Surge Current Unidirectional Only (Note 4)	I_{FSM}	300	A

Note:

1. Halogen free "Green" products are defined as those which contain <900ppm bromine, <900ppm chlorine (<1500ppm total Br + Cl) and <1000ppm antimony compounds.
2. High Temperature Solder Exemption Applied, see EU Directive Annex 7a.
3. Non-repetitive current pulse, per Fig.3 and derated above $T_A = 25^\circ C$ per Fig.4.
4. 8.3ms, single half sine wave duty cycle = 4 pulses per Minutes maximum.

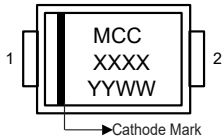
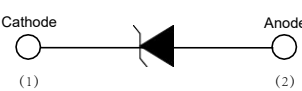
Internal Structure

Description	Simplified outline	Graphic symbol
Uni-directional		
Bi-directional		

XXXX = Marking code YYWW = Date Code

5000Watt TVS
5.0 to 85
Volts

SMC (DO-214AB)
(LEAD FRAME)

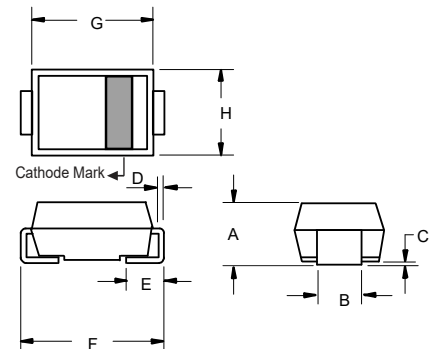

DIMENSIONS

DIM	INCHES		MM		NOTE
	MIN	MAX	MIN	MAX	
A	0.079	0.103	2.00	2.62	
B	0.108	0.128	2.75	3.25	
C	0.002	0.008	0.051	0.203	
D	0.006	0.012	0.152	0.305	
E	0.030	0.060	0.76	1.52	
F	0.305	0.320	7.75	8.13	
G	0.260	0.280	6.60	7.11	
H	0.220	0.245	5.59	6.22	

Suggested Solder Pad Layout

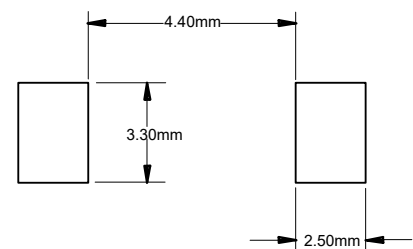

Thermal Characteristics

Parameter	Symbol	Value	Unit
Operating Junction Temperature Range	T_J	-55 to +175	°C
Storage Temperature Range	T_{STG}	-55 to +175	°C
Typical Thermal Resistance Junction to Lead	$R_{\theta JL}$	15	°C/W
Typical Thermal Resistance Junction to Ambient	$R_{\theta JA}$	75	°C/W
Typical Thermal Resistance Junction to Case	$R_{\theta JC}$	13	°C/W

Note:

5. Mounted on 0.31 x 0.31" (8.0 x 8.0 mm) copper pads to each terminal.

Electrical Characteristics @ 25°C Unless Otherwise Specified

MCC Part Number		Reverse Stand-Off Voltage	Breakdown Voltage VBR(V)		Test Current	Max. Clamping Voltage @IPP	Peak Pulse Current	Reverse Leakage Current@VRWM	Marking Code	
Uni-directional	Bi-directional	V _{RWM} (V)	Min (V)	Max (V)	I _T (mA)	V _C (V)	I _{PP} (A)	I _R (μA)	Uni	Bi
5.0SMLJ5.0AHE3	5.0SMLJ5.0CAHE3	5.0	6.40	7.00	10	9.2	543.6	1000	5PDE	5BDE
5.0SMLJ6.0AHE3	5.0SMLJ6.0CAHE3	6.0	6.67	7.37	10	10.3	485.5	1000	5PDG	5BDG
5.0SMLJ6.5AHE3	5.0SMLJ6.5CAHE3	6.5	7.22	7.98	10	11.2	446.5	800	5PDK	5BDK
5.0SMLJ7.0AHE3	5.0SMLJ7.0CAHE3	7.0	7.78	8.60	10	12.0	416.8	800	5PDP	5BDP
5.0SMLJ7.5AHE3	5.0SMLJ7.5CAHE3	7.5	8.33	9.21	5	12.9	387.7	800	5PDR	5BDR
5.0SMLJ8.0AHE3	5.0SMLJ8.0CAHE3	8.0	8.89	9.83	5	13.6	367.7	800	5PDT	5BDT
5.0SMLJ8.5AHE3	5.0SMLJ8.5CAHE3	8.5	9.44	10.40	5	14.4	347.3	800	5PDV	5BDV
5.0SMLJ9.0AHE3	5.0SMLJ9.0CAHE3	9.0	10.00	11.10	5	15.4	324.8	800	5PDX	5BDX
5.0SMLJ10AHE3	5.0SMLJ10CAHE3	10.0	11.10	12.30	1	17.0	294.1	5	5SAE	5DAE
5.0SMLJ11AHE3	5.0SMLJ11CAHE3	11.0	12.20	13.50	1	18.2	275.0	2	5SAF	5DAF
5.0SMLJ12AHE3	5.0SMLJ12CAHE3	12.0	13.30	14.70	1	19.9	252.0	2	5SAG	5DAG
5.0SMLJ13AHE3	5.0SMLJ13CAHE3	13.0	14.40	15.90	1	21.5	233.0	2	5SAK	5DAK
5.0SMLJ14AHE3	5.0SMLJ14CAHE3	14.0	15.60	17.20	1	23.2	216.0	2	5SAM	5DAM
5.0SMLJ15AHE3	5.0SMLJ15CAHE3	15.0	16.70	18.50	1	24.4	205.0	2	5SAP	5DAP
5.0SMLJ16AHE3	5.0SMLJ16CAHE3	16.0	17.80	19.70	1	26.0	193.0	2	5SAR	5DAR
5.0SMLJ17AHE3	5.0SMLJ17CAHE3	17.0	18.90	20.90	1	27.6	181.0	2	5SAT	5DAT
5.0SMLJ18AHE3	5.0SMLJ18CAHE3	18.0	20.00	22.10	1	29.2	172.0	2	5SAV	5DAV
5.0SMLJ19AHE3	5.0SMLJ19CAHE3	19.0	21.10	23.30	1	30.8	162.4	2	5SAX	5DAX
5.0SMLJ20AHE3	5.0SMLJ20CAHE3	20.0	22.20	24.50	1	32.4	155.0	2	5SAZ	5DAZ
5.0SMLJ22AHE3	5.0SMLJ22CAHE3	22.0	24.40	26.90	1	35.5	141.0	2	5SBE	5DBE
5.0SMLJ24AHE3	5.0SMLJ24CAHE3	24.0	26.70	29.50	1	38.9	129.0	2	5SBF	5DBF
5.0SMLJ26AHE3	5.0SMLJ26CAHE3	26.0	28.90	31.90	1	42.1	119.0	2	5SBG	5DBG
5.0SMLJ28AHE3	5.0SMLJ28CAHE3	28.0	31.10	34.40	1	45.4	110.0	2	5SBK	5DBK
5.0SMLJ30AHE3	5.0SMLJ30CAHE3	30.0	33.30	36.80	1	48.4	103.0	2	5SBM	5DBM
5.0SMLJ33AHE3	5.0SMLJ33CAHE3	33.0	36.70	40.60	1	53.3	93.9	2	5SBP	5DBP
5.0SMLJ36AHE3	5.0SMLJ36CAHE3	36.0	40.00	44.20	1	58.1	86.1	2	5SBR	5DBR
5.0SMLJ40AHE3	5.0SMLJ40CAHE3	40.0	44.40	49.10	1	64.5	77.6	2	5SBT	5DBT
5.0SMLJ43AHE3	5.0SMLJ43CAHE3	43.0	47.80	52.80	1	69.4	72.1	2	5SBV	5DBV
5.0SMLJ45AHE3	5.0SMLJ45CAHE3	45.0	50.00	55.30	1	72.7	68.8	2	5SBX	5DBX
5.0SMLJ48AHE3	5.0SMLJ48CAHE3	48.0	53.30	58.90	1	77.4	64.7	2	5SBZ	5DBZ
5.0SMLJ51AHE3	5.0SMLJ51CAHE3	51.0	56.70	62.70	1	82.4	60.7	2	5SCE	5DCE
5.0SMLJ54AHE3	5.0SMLJ54CAHE3	54.0	60.00	66.30	1	87.1	57.5	2	5SCF	5DCF
5.0SMLJ58AHE3	5.0SMLJ58CAHE3	58.0	64.40	71.20	1	93.6	53.5	2	5SCG	5DCG
5.0SMLJ60AHE3	5.0SMLJ60CAHE3	60.0	66.70	73.70	1	96.8	51.7	2	5PGK	5BGK
5.0SMLJ64AHE3	5.0SMLJ64CAHE3	64.0	71.10	78.60	1	103.0	48.5	2	5PGM	5BGM
5.0SMLJ70AHE3	5.0SMLJ70CAHE3	70.0	77.80	86.00	1	113.0	44.2	2	5PGP	5BGP
5.0SMLJ75AHE3	5.0SMLJ75CAHE3	75.0	83.30	92.10	1	121.0	41.3	2	5PGR	5BGR
5.0SMLJ78AHE3	5.0SMLJ78CAHE3	78.0	86.70	95.80	1	126.0	39.7	2	5PGT	5BGT
5.0SMLJ80AHE3	5.0SMLJ80CAHE3	80.0	88.90	97.60	1	129.6	38.6	2	5PGU	5BGU
5.0SMLJ85AHE3	5.0SMLJ85CAHE3	85.0	94.40	104.00	1	137.0	36.5	2	5PGV	5BGV

Note:

4. Add suffix 'C' after part number to specify Bi-directional devices
5. For Bi-Directional devices having V_R of 10 volts, the I_R limit is double

Curve Characteristics

Fig. 1 - Peak Pulse Power Rating Curve

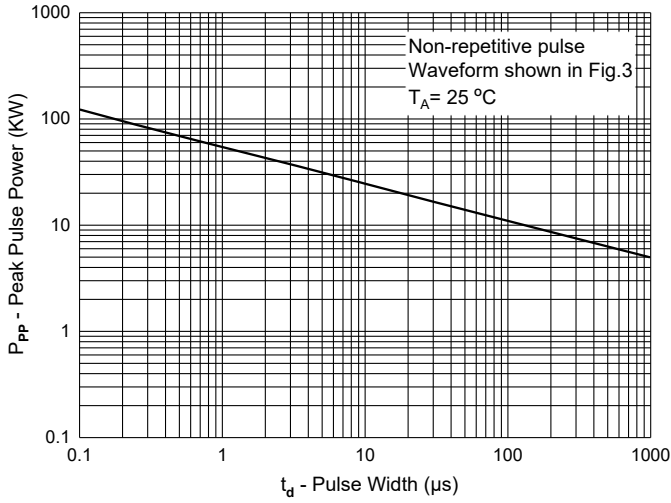

Fig. 2 - Typical Junction Capacitance

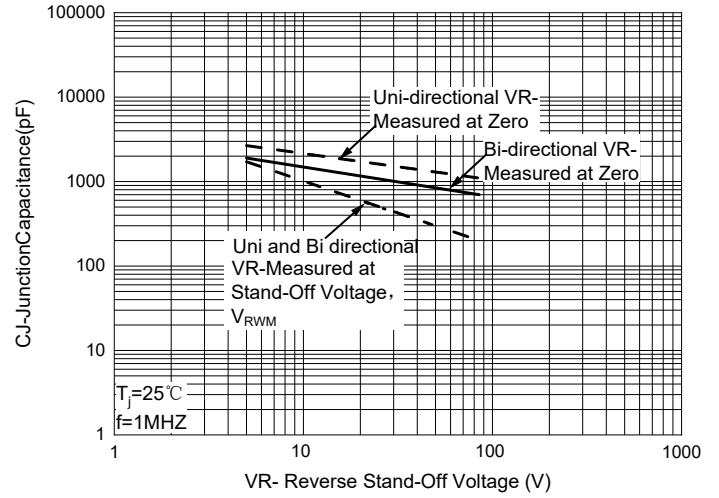

Fig. 3 - Pulse Waveform

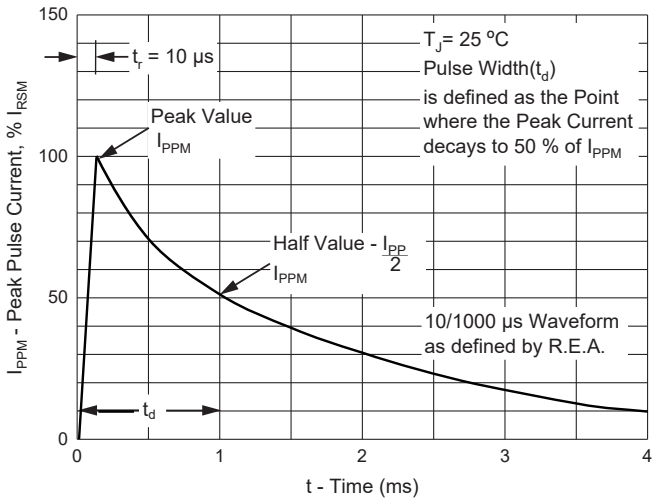
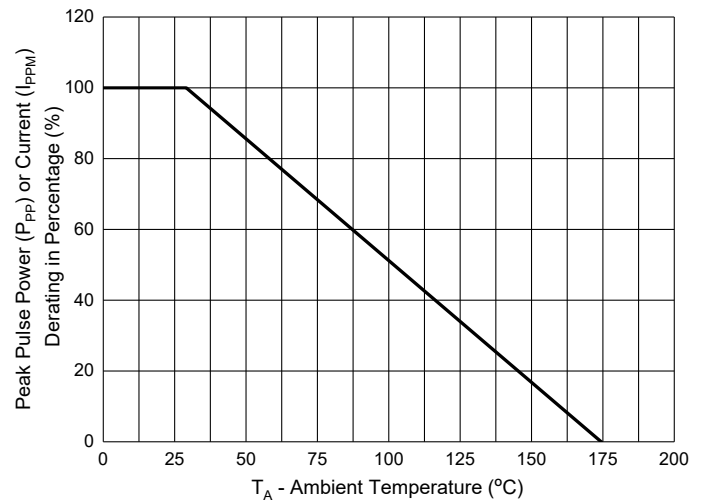

Fig. 4 - Pulse Derating Curve



Ordering Information

Device	Packing
Part Number-TP	Tape&Reel:3Kpcs/Reel

IMPORTANT NOTICE

Micro Commercial Components Corp. reserves the right to make changes without further notice to any product herein to make corrections, modifications, enhancements, improvements, or other changes. **Micro Commercial Components Corp.** does not assume any liability arising out of the application or use of any product described herein; neither does it convey any license under its patent rights, nor the rights of others. The user of products in such applications shall assume all risks of such use and will agree to hold **Micro Commercial Components Corp.** and all the companies whose products are represented on our website, harmless against all damages. **Micro Commercial Components Corp.** products are sold subject to the general terms and conditions of commercial sale, as published at <https://www.mccsemi.com/Home/TermsAndConditions>.

LIFE SUPPORT

MCC's products are not authorized for use as critical components in life support devices or systems without the express written approval of Micro Commercial Components Corporation.

CUSTOMER AWARENESS

Counterfeiting of semiconductor parts is a growing problem in the industry. Micro Commercial Components (MCC) is taking strong measures to protect ourselves and our customers from the proliferation of counterfeit parts. MCC strongly encourages customers to purchase MCC parts either directly from MCC or from Authorized MCC Distributors who are listed by country on our web page cited below. Products customers buy either from MCC directly or from Authorized MCC Distributors are genuine parts, have full traceability, meet MCC's quality standards for handling and storage. **MCC will not provide any warranty coverage or other assistance for parts bought from Unauthorized Sources.** MCC is committed to combat this global problem and encourage our customers to do their part in stopping this practice by buying direct or from authorized distributors.