

Features

Frequency range : 10MHz to 114MHz
 Ceramic SMD package
 Seam sealing
 External dimensions (mm)
 L : 3.2 x W : 2.5 x H : 0.7
 RoHS compliant & Pb free

Applications

Bluetooth, Wireless LAN
 Cellular phone, Pager, DSC
 Display, TV
 Computer peripherals
 Consumer products

Electrical Characteristics

Item		7M	Conditions
Frequency Range	F_0	10MHz ~ 114MHz	
Frequency Tolerance	F_{tol}	±30ppm, ±20ppm, ±10ppm	at 25°C
Frequency Stability over Operating Temperature Range (refer to 25°C)	F_{stab}	±30 ppm	-20°C ~ +70°C
		±20 ppm	
		±10 ppm	
		±10 ppm	-30°C ~ +85°C
		±30 ppm	
		±20 ppm	
		±15 ppm	
±60 ppm	-40°C ~ +125°C		
Operating Temperature Range	T_{OTR}	-20°C ~ +70°C	
		-40°C ~ +85°C	
		-40°C ~ +125°C	
Shunt Capacitance	C_0	3pF Max.	
Drive Level	D_L	1 ~ 200µW (100µW Typ.)	
Load Capacitance	C_L	6pF, 7pF, 8pF, 9pF, 10pF 12pF, 16pF, 18pF, 20pF	
Aging (at 25°C ± 3°C, first year)	F_{aging}	±3ppm Max.	Note [1]
Storage Temperature Range	T_{STR}	-40°C ~ +85°C	

Notes:

[1] Please contact us for low aging +/-1ppm grade crystals.

Motional Resistance (ESR)

Fundamental	
10 ~ 12 MHz	150Ω Max.
12 ~ 16 MHz	80Ω Max.
16 ~ 20 MHz	60Ω Max.
20 ~ 64 MHz	50Ω Max.

3rd Overtone	
60 ~ 80 MHz	80Ω Max.
80 ~ 114 MHz	60Ω Max.

Dimensions

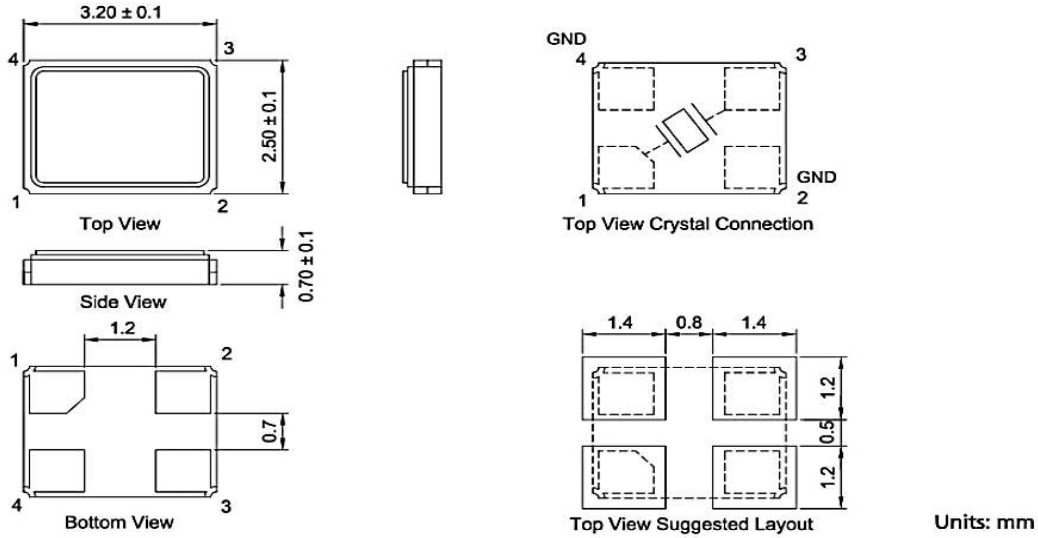

Ordering Information

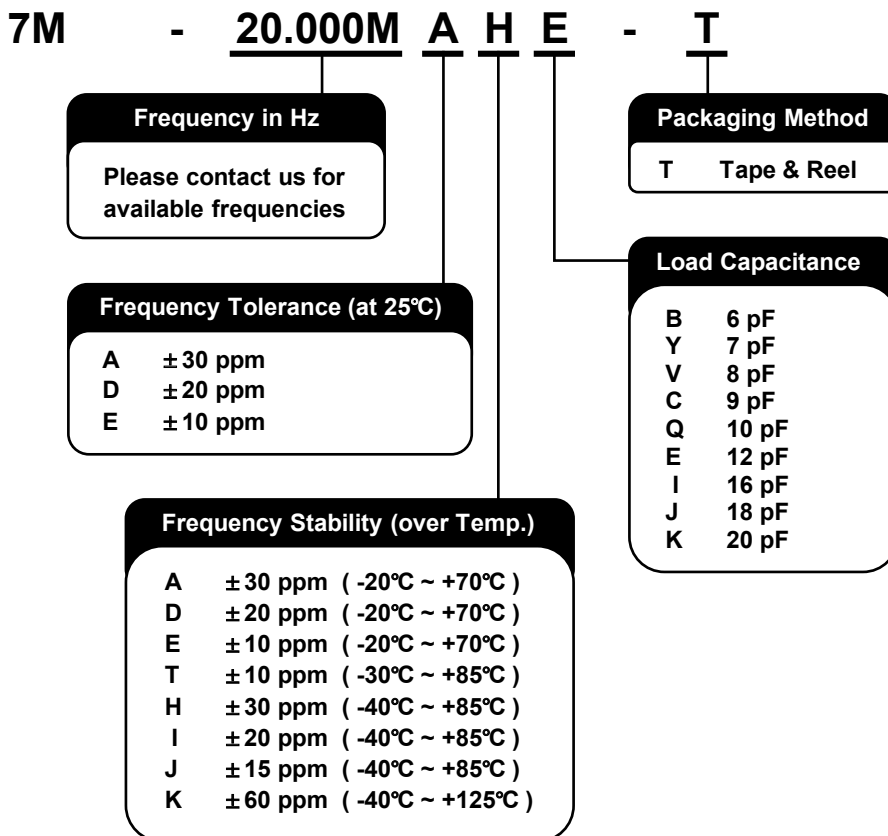

Packing

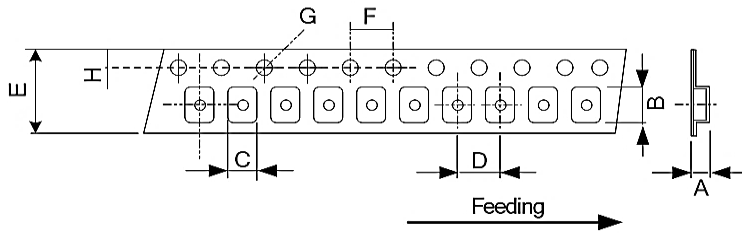

DIMENSIONS	A	B	C	D	E	F	G	H
	1.65	3.40	2.70	4.00	8.00	4.00	1.55	1.75
	±0.10	±0.10	±0.10	±0.10	±0.20	±0.10	±0.05	±0.10

(Unit: mm)

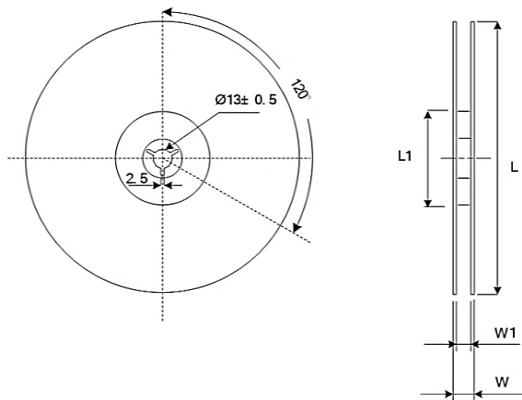

DIMENSIONS	L	L1	W	W1
	178	60.2	11.5	8
	±1.00	±0.50	±0.2	±0.1

(Unit: mm)

Reflow Profile

Solder melting point : 220°C ± 10°C, 60 sec. Min.

Peak temperature : 260°C ± 10°C, 10 sec. Min.

