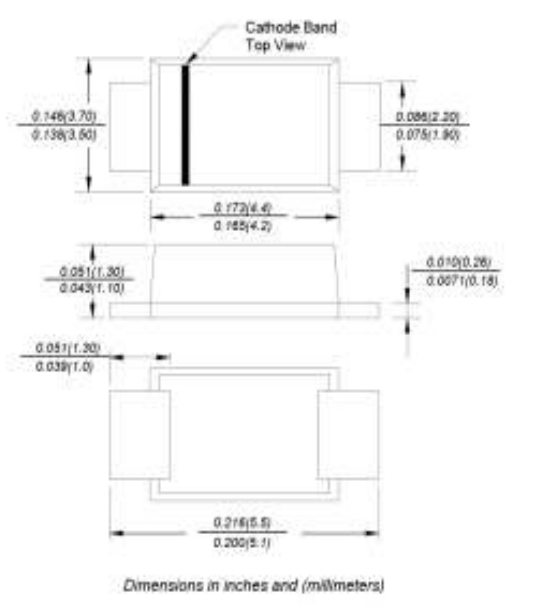

SURFACE MOUNT SUPERFAST RECOVERY RECTIFIER

Reverse Voltage - 50 to 600 Volts Forward Current - 3.0 Amperes

<div style="text-align: center;">SMBF</div>  <p style="text-align: center; font-size: small;">Dimensions in inches and (millimeters)</p>	<div style="text-align: center;">FEATURES</div> <ul style="list-style-type: none"> ◆ For surface mounted applications ◆ Low profile package ◆ Glass Passivated Chip Junction ◆ Superfast reverse recovery time ◆ Lead free in comply with EU RoHS 2011/65/EU directives
<div style="text-align: center;">MECHANICAL DATA</div> <p>Case: JEDEC SMBF molded plastic body Terminals: leads solderable per MIL-STD-750, Method 2026 Mounting Position: Any Weight: 57mg/0.002oz</p>	

MAXIMUM RATINGS AND ELECTRICAL CHARACTERISTICS

Ratings at 25°C ambient temperature unless otherwise specified.
 Single phase half-wave 60Hz, resistive or inductive load, for capacitive load current derate by 20%.

TWGMC Catalog Number	SYMBOLS	ES3ABF	ES3BBF	ES3DBF	ES3GBF	ES3JBF	UNITS
Maximum repetitive peak reverse voltage	V_{RRM}	50	100	200	400	600	VOLTS
Maximum RMS voltage	V_{RMS}	35	70	140	280	420	VOLTS
Maximum DC blocking voltage	V_{DC}	50	100	200	400	600	VOLTS
Maximum average forward rectified current at $T_L=100^\circ\text{C}$	$I_{(AV)}$	3.0					Amps
Peak forward surge current 8.3ms single half sine-wave superimposed on rated load (JEDEC Method)	I_{FSM}	100					Amps
Maximum instantaneous forward voltage at 3.0A	V_F	1.0		1.25		1.7	Volts
Maximum DC reverse current $T_A=25^\circ\text{C}$ at rated DC blocking voltage $T_A=125^\circ\text{C}$	I_R	5.0 100.0					μA
Maximum reverse recovery time (NOTE 1)	t_{rr}	35					ns
Typical junction capacitance (NOTE 2)	C_j	45.0					pF
Typical thermal resistance (NOTE 3)	$R_{\theta JA}$	55.0					$^\circ\text{C/W}$
Operating junction and storage temperature range	T_J, T_{STG}	-55 to +150					$^\circ\text{C}$

Note: 1. Reverse recovery condition $I_F=0.5\text{A}, I_R=1.0\text{A}, I_{rr}=0.25\text{A}$
 2. Measured at 1MHz and applied reverse voltage of 4.0V D.C.
 3. P.C.B. mounted with 0.5x0.5" (12.7x12.7mm) copper pad areas

RATINGS AND CHARACTERISTIC CURVES ES3ABF THRU ES3JBF

Fig.1 Reverse Recovery Time Characteristic And Test Circuit Diagram

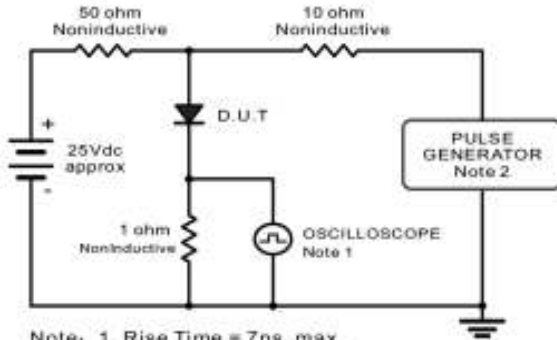

Note: 1. Rise Time = 7ns, max.
Input Impedance = 1megohm, 22pF.
2. Rise Time = 10ns, max.
Source Impedance = 50 ohms.

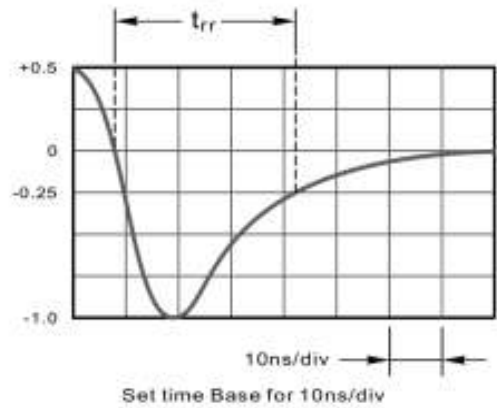

Fig.2 Maximum Average Forward Current Rating

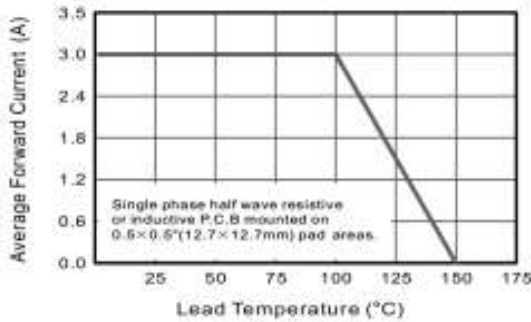

Fig.3 Typical Reverse Characteristics

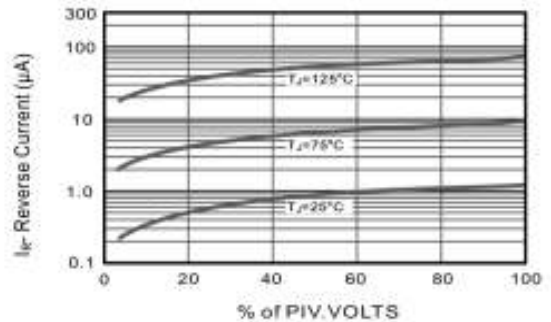

Fig.4 Typical Forward Characteristics

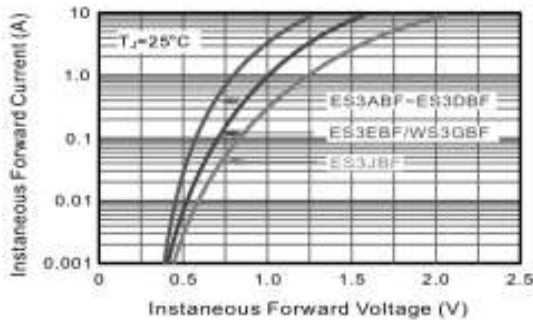

Fig.5 Typical Junction Capacitance

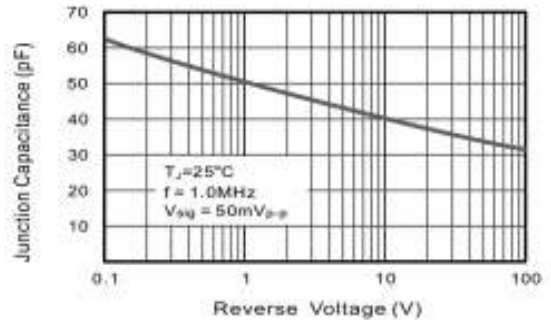

Fig.6 Maximum Non-Repetitive Peak Forward Surge Current

