



DESCRIPTION

The popular 1N4099 thru 1N4135 and 1N4614 thru 1N4627 series of 0.5 watt Zener Voltage Regulators provides a selection from 1.8 to 100 volts in standard 5% tolerances as well as tighter tolerances identified by different suffix letters on the part number. The DO-7 packaging option offers a "straight-through" soldered internal connection with a larger active die element than otherwise provided in the smaller DO-35 package when needed. Microsemi also offers numerous other Zener products to meet higher and lower power applications.

APPEARANCE

**DO-7
(DO-204AA)**

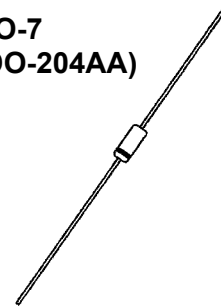

IMPORTANT: For the most current data, consult MICROSEMI's website: <http://www.microsemi.com>

FEATURES

- JEDEC registered 1N4099 thru 1N4135 and 1N4614 thru 1N4627 series
- Internally solder bonded
- Also available in JAN, JANTX, and JANTXV qualifications per MIL-PRF-19500/435 by adding the JAN, JANTX, or JANTXV prefixes to part numbers for desired screening level as well as "-1" suffix: e.g. JANTX1N4099-1, JANTXV1N4109D-1, etc.
- Military Surface Mount available in DO-213AA package outline by adding a UR-1 suffix in addition to the JAN, JANTX, and JANTXV prefix; e.g. JANTX1N4099UR-1 (see separate data sheet)
- Commercial Surface Mount also available in separate data sheet as 1N4099UR to 1N4135UR, and 1N4614UR to 1N4627UR in DO-213AA package (consult factory for others)
- Smaller DO-35 glass body axial-leaded Zener equivalents are also available

APPLICATIONS / BENEFITS

- Regulates voltage over a broad operating current and temperature range
- Extensive selection from 1.8 to 100 V
- Standard voltage tolerances are plus/minus 5% with no suffix
- Tight tolerances available in plus or minus 2% or 1% with C or D suffix respectively
- Flexible axial-lead mounting terminals
- Nonsensitive to ESD per MIL-STD-750 Method 1020
- Capacitance also specified (see Figure 3)
- Inherently radiation hard as described in Microsemi MicroNote 050

MAXIMUM RATINGS

- Operating and Storage temperature: -65°C to +175°C
- Thermal Resistance: 300 °C/W junction to lead at 3/8 (10 mm) lead length from body, or 360 °C/W junction to ambient when mounted on FR4 PC board (1 oz Cu) with 4 mm² copper pads and track width 1 mm, length 25 mm
- Steady-State Power: 0.5 watts at T_L ≤ 25°C 3/8 inch (10 mm) from body or 0.417 W at T_A ≤ 25°C when mounted on FR4 PC board as described for thermal resistance above (also see Figure 2)
- Forward voltage @200 mA: 1.1 volts (maximum)
- Solder Temperatures: 260 °C for 10 s (max)

MECHANICAL AND PACKAGING

- CASE: Hermetically sealed axial-lead glass DO-7 (DO-204AA) package
- TERMINALS: Leads, tin-lead plated solderable per MIL-STD-750, method 2026
- POLARITY: Cathode indicated by band where diode is to be operated with the banded end positive with respect to the opposite end for Zener regulation
- MARKING: Part number
- TAPE & REEL option: Standard per EIA-296 (add "TR" suffix to part number)
- WEIGHT: 0.2 grams
- See package dimensions on last page

1N4099 - 1N4135-1 &
1N4614 - 1N4627-1 (DO-7)

*** ELECTRICAL CHARACTERISTICS @ 25°C**

JEDEC TYPE NO.	NOMINAL ZENER VOLTAGE $V_Z @ I_{ZT}$ (Note 1)	ZENER TEST CURRENT I_{ZT}	MAXIMUM ZENER IMPEDANCE Z_{ZT} (Note 2)	MAXIMUM REVERSE CURRENT $I_R @ V_R$		MAXIMUM NOISE DENSITY $N_D @ I_{ZT}$ (Figure 1)	MAXIMUM ZENER CURRENT I_{ZM} (Note 3)	MAXIMUM TEMP. COEFF. OF ZENER VOLTAGE α_{VZ}
	VOLTS	μA	OHMS	μA	VOLTS	$\mu V / \sqrt{HZ}$	mA	%/°C
1N4614	1.8	250	1200	7.5	1	1	120	-0.075
1N4615	2.0	250	1250	5.0	1	1	110	-0.075
1N4616	2.2	250	1300	4.0	1	1	100	-0.075
1N4617	2.4	250	1400	2.0	1	1	95	-0.075
1N4618	2.7	250	1500	1.0	1	1	90	-0.075
1N4619	3.0	250	1600	0.8	1	1	87	-0.075
1N4620	3.3	250	1650	7.5	1.5	1	85	-0.075
1N4621	3.6	250	1700	7.5	2	1	83	-0.065
1N4622	3.9	250	1650	5.0	2	1	80	-0.060
1N4623	4.3	250	1600	4.0	2	1	77	-0.050
1N4624	4.7	250	1550	10.0	3	1	75	-0.050+0.020
1N4625	5.1	250	1500	10.0	3	2	70	-0.045 +0.030
1N4626	5.6	250	1400	10.0	4	4	65	-0.020 +0.040
1N4627	6.2	250	1200	10.0	5	5	61	-0.010 +0.050
1N4099	6.8	250	200	10.0	5.17	40	56	0.060
1N4100	7.5	250	200	10.0	5.70	40	51	0.065
1N4101	8.2	250	200	1.0	6.24	40	46	0.070
1N4102	8.7	250	200	1.0	6.61	40	44	0.075
1N4103	9.1	250	200	1.0	6.92	40	42	0.080
1N4104	10	250	200	1.0	7.60	40	38	0.080
1N4105	11	250	200	.05	8.44	40	35	0.080
1N4106	12	250	200	.05	8.12	40	32	0.080
1N4107	13	250	200	.05	9.857	40	29	0.080
1N4108	14	250	200	.05	10.65	40	27	0.085
1N4109	15	250	100	.05	11.40	40	25	0.085
1N4110	16	250	100	.05	12.15	40	24	0.085
1N4111	17	250	100	.05	12.92	40	22	0.090
1N4112	18	250	100	.05	13.67	40	21	0.090
1N4113	19	250	150	.05	14.44	40	20	0.090
1N4114	20	250	150	.01	15.20	40	19	0.090
1N4115	22	250	150	.01	16.72	40	17	0.090
1N4116	24	250	150	.01	18.25	40	16	0.090
1N4117	25	250	150	.01	19.00	40	15	0.090
1N4118	27	250	150	.01	20.45	40	14	0.090
1N4119	28	250	200	.01	21.28	40	14	0.095
1N4120	30	250	200	.01	22.80	40	13	0.095
1N4121	33	250	200	.01	25.08	40	12	0.095
1N4122	36	250	200	.01	27.38	40	11	0.095
1N4123	39	250	200	.01	29.65	40	9.8	0.095
1N4124	43	250	250	.01	32.65	40	8.9	0.095
1N4125	47	250	250	.01	35.75	40	8.1	0.095
1N4126	51	250	300	.01	38.76	40	7.5	0.100
1N4127	56	250	300	.01	42.60	40	6.7	0.100
1N4128	60	250	400	.01	45.60	40	6.4	0.100
1N4129	62	250	500	.01	47.10	40	6.1	0.100
1N4130	68	250	700	.01	51.68	40	5.6	0.100
1N4131	75	250	700	.01	57.00	40	5.1	0.100
1N4132	82	250	800	.01	62.32	40	4.6	0.100
1N4133	87	250	1000	.01	66.12	40	4.4	0.100
1N4134	91	250	1200	.01	69.16	40	4.2	0.100
1N4135	100	250	1500	.01	76.00	40	3.8	0.100

*JEDEC Registered Data.

- NOTES:**
- The JEDEC type numbers shown with no suffix have a standard tolerance of +/-5% on the nominal Zener voltage: suffix C is used to identify +/-2%; and suffix D is to identify +/-1% tolerance. V_Z is measured with the diode in thermal equilibrium in 25°C still air.
 - Zener impedance is derived by superimposing on I_{ZT} a 60 Hz rms ac current equal to 10% of I_{ZT} (25 μA). See MicroNote 202 for zener impedance variation with different operating currents.
 - Based upon 400 mW maximum power dissipation at 25°C lead temperature, allowance has been made for the higher voltage associated with operation at higher currents.

OUTLINE AND CIRCUIT

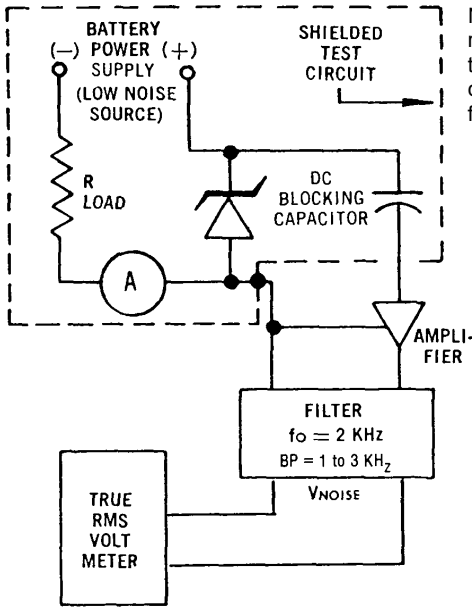
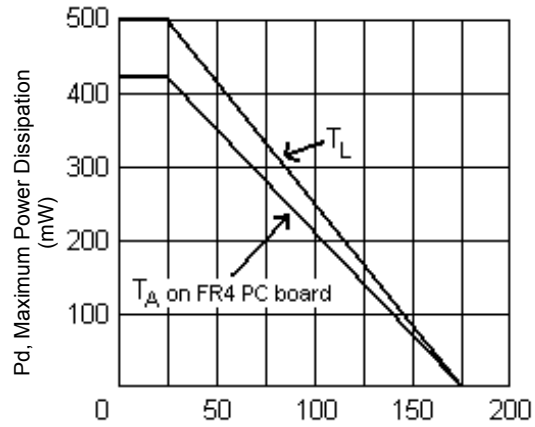

FIGURE 1

Noise Density Measurement Circuit

Noise density, (N_D) is specified in microvolt-rms per square-root-hertz. Actual measurement is performed using a 1 kHz to 3 kHz frequency bandpass filter at a constant Zener test current (I_{ZT}) AT 25°C ambient temperature. N_D is calculated from the formula.



T_L – Lead Temperature (°C) 3/8" from body
or T_A on FR4 PC Board

FIGURE 2 – Power Derating Curve

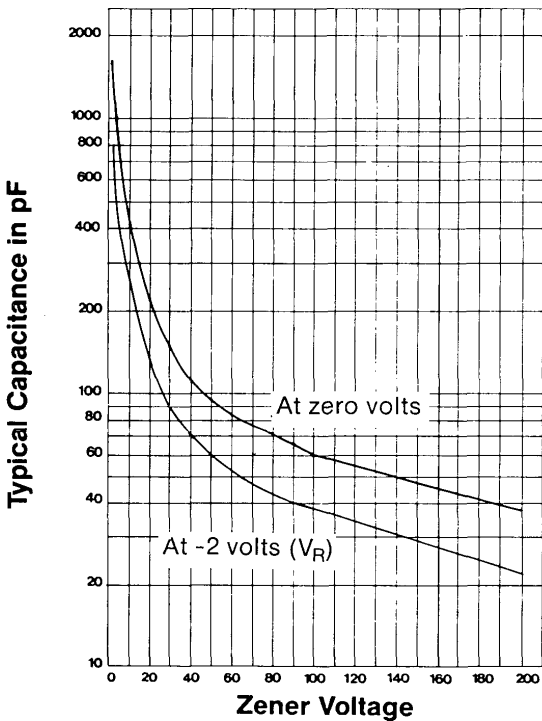
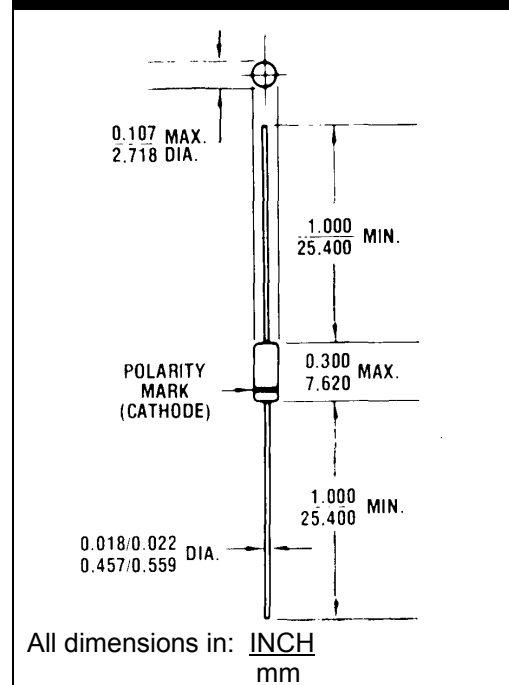

FIGURE 3

CAPACITANCE vs. ZENER VOLTAGE
(TYPICAL)

PACKAGE DIMENSIONS



All dimensions in: INCH
mm