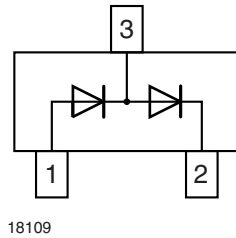
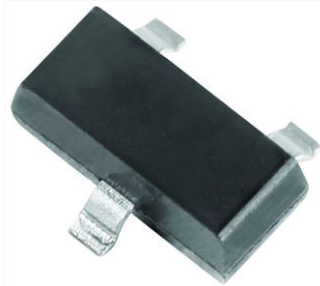


Small Signal Switching Diode, Dual in Series



FEATURES

- Fast switching speed
- High conductance
- Surface mount package ideally suited for automatic insertion
- Connected in series
- AEC-Q101 qualified available (part number on request)
- Molding compound meets UL 94 V-0 flammability rating
- Moisture sensitivity level (MSL) 1
- Base P/N-G3 - green, commercial grade
- Material categorization: for definitions of compliance please see www.vishay.com/doc?99912



LINKS TO ADDITIONAL RESOURCES



MECHANICAL DATA

Case: SOT-23

Weight: approx. 9.2 mg

Packaging codes / options:

18/10K per 13" reel (8 mm tape), 10K/box

08/3K per 7" reel (8 mm tape), 15K/box

| PARTS TABLE | | | | | | |
|-------------|---------------|--------------------|--------------|-----------------------|-----------------------------------|------------------------|
| PART | ORDERING CODE | AEC-Q101 QUALIFIED | TYPE MARKING | CIRCUIT CONFIGURATION | TAPED UNITS PER REEL | MINIMUM ORDER QUANTITY |
| BAV99-G | BAV99-G3-08 | no | JEG | Dual serial | 3 000 (8 mm tape on 7" reel) | 15 000 |
| | BAV99-G3-18 | no | | | 10 000 (8 mm tape on 13" reel) | 10 000 |

| ABSOLUTE MAXIMUM RATINGS ($T_{amb} = 25\text{ }^{\circ}\text{C}$, unless otherwise specified) | | | | |
|---|--|---------------------------|-------|------|
| PARAMETER | TEST CONDITION | SYMBOL | VALUE | UNIT |
| Non repetitive peak reverse voltage | | V_{RM} | 100 | V |
| Repetitive peak reverse voltage = working peak reverse voltage = DC blocking voltage | | $V_{RRM} = V_{RWM} = V_R$ | 70 | |
| Peak forward surge current ⁽¹⁾ | $t_p = 1\text{ s}$ | I_{FSM} | 1 | A |
| | $t_p = 1\text{ }\mu\text{s}$ | | 4.5 | |
| Average forward current ⁽¹⁾ | Half wave rectification with resistive load and $f \geq 50\text{ MHz}$ | $I_{F(AV)}$ | 250 | mA |
| Forward current ⁽¹⁾ | | I_F | 350 | |
| Power dissipation | on FR-4 board with recommended soldering footprint | P_{tot} | 270 | mW |
| | Infinite heatsink | | 390 | |

Note

⁽¹⁾ Infinite heatsink

| THERMAL CHARACTERISTICS ($T_{amb} = 25\text{ }^{\circ}\text{C}$, unless otherwise specified) | | | | |
|--|---|------------|-------------|--------------------|
| PARAMETER | TEST CONDITION | SYMBOL | VALUE | UNIT |
| Thermal resistance junction to ambient air | according to JEDEC [®] 51-3 on FR-4 board with recommended soldering footprint | R_{thJA} | 460 | K/W |
| Thermal resistance junction to lead | Infinite heatsink | R_{thJL} | 320 | K/W |
| Junction temperature | | T_j | 150 | $^{\circ}\text{C}$ |
| Storage temperature range | | T_{stg} | -65 to +150 | $^{\circ}\text{C}$ |
| Operating temperature range | | T_{op} | -55 to +150 | $^{\circ}\text{C}$ |

| ELECTRICAL CHARACTERISTICS ($T_{amb} = 25\text{ }^{\circ}\text{C}$, unless otherwise specified) | | | | |
|--|--|----------|-------|---------------|
| PARAMETER | TEST CONDITION | SYMBOL | MAX. | UNIT |
| Forward voltage | $I_F = 1\text{ mA}$ | V_F | 0.715 | V |
| | $I_F = 10\text{ mA}$ | | 0.855 | V |
| | $I_F = 50\text{ mA}$ | | 1 | V |
| | $I_F = 150\text{ mA}$ | | 1.25 | V |
| Reverse current | $V_R = 70\text{ V}$ | I_R | 100 | nA |
| | $V_R = 70\text{ V}, T_J = 150\text{ }^{\circ}\text{C}$ | | 50 | μA |
| | $V_R = 25\text{ V}, T_J = 150\text{ }^{\circ}\text{C}$ | | 30 | μA |
| Diode capacitance | $V_R = 0, f = 1\text{ MHz}$ | C_D | 1.5 | pF |
| Reverse recovery time | $I_F = 10\text{ mA}$ to $i_R = 1\text{ mA}$, $V_R = 6\text{ V}$, $R_L = 100\ \Omega$ | t_{rr} | 6 | ns |

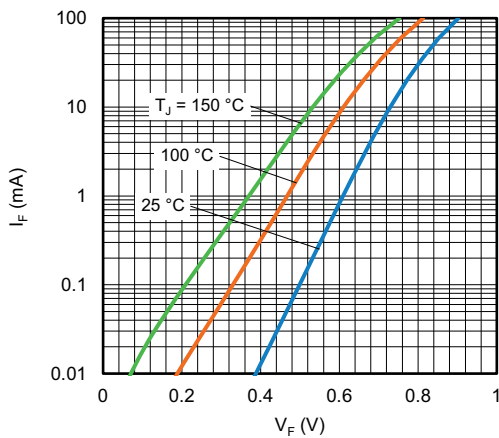
TYPICAL CHARACTERISTICS ($T_{amb} = 25\text{ }^{\circ}\text{C}$, unless otherwise specified)


Fig. 1 - Forward Current vs. Forward Voltage

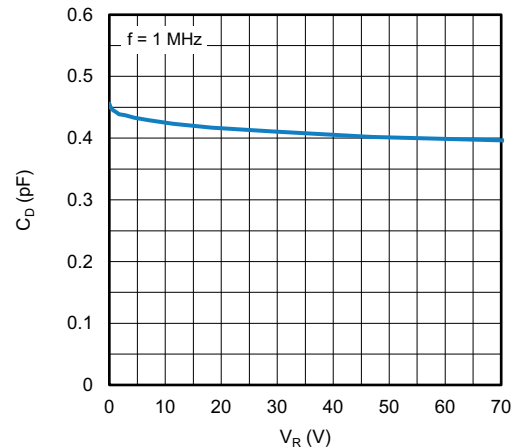


Fig. 3 - Typical Capacitance vs. Reverse Voltage

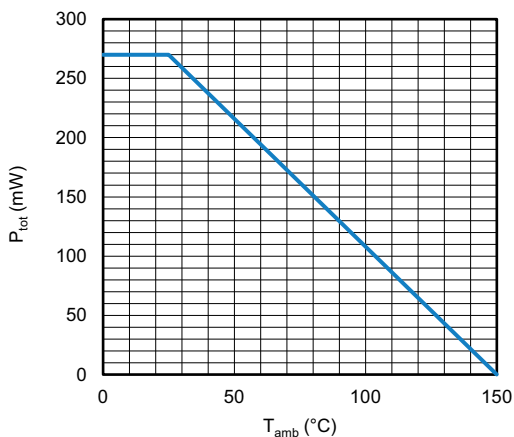


Fig. 2 - Admissible Power Dissipation vs. Ambient Temperature

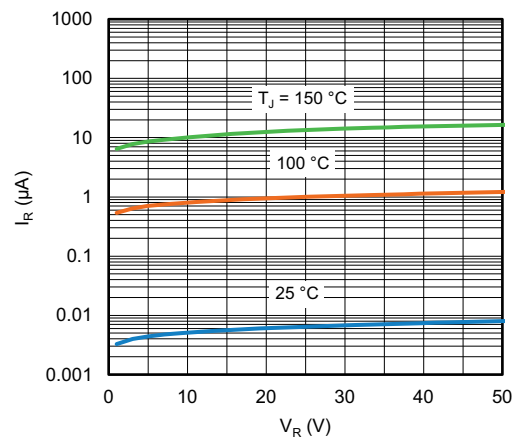
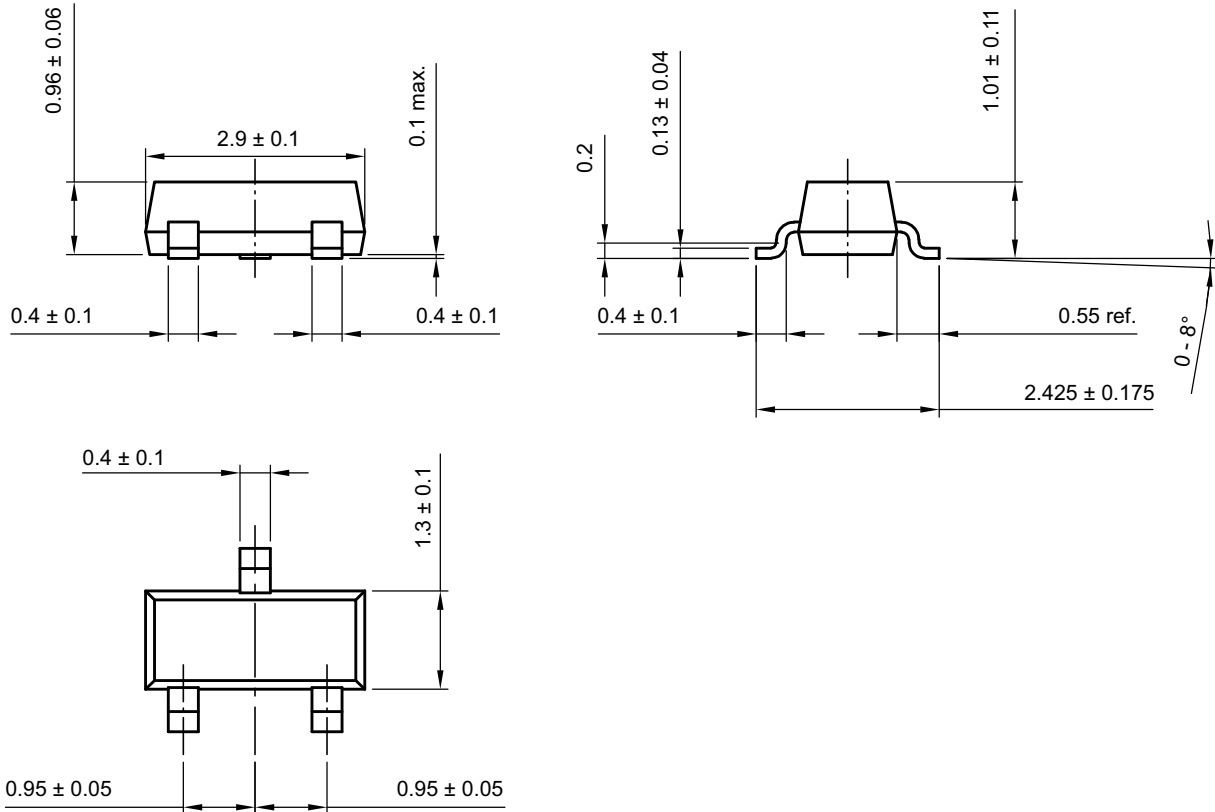


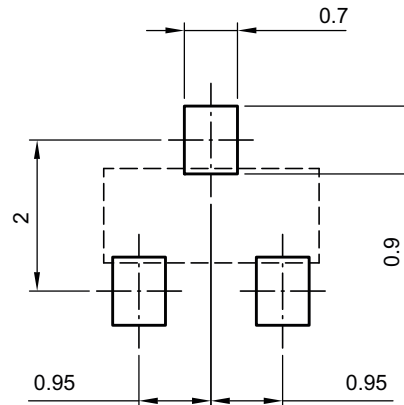
Fig. 4 - Typical Reverse Leakage Current vs. Reverse Voltage



PACKAGE DIMENSIONS in millimeters: **SOT-23**

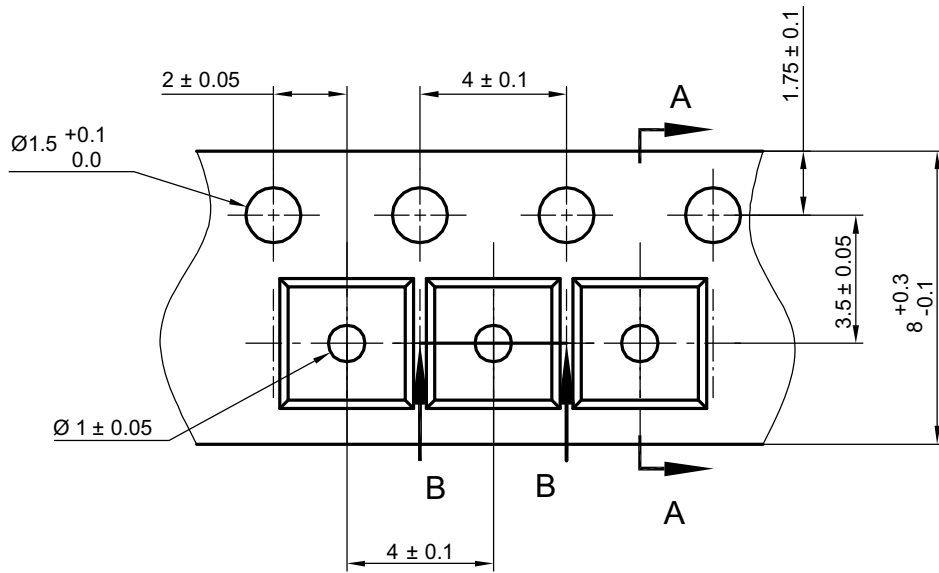


footprint recommendation:

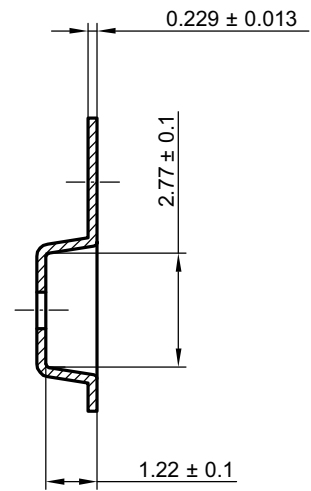


Created - Date: 18-Oct-2021
Rev. 01 - Date: 18-Jan-2022
S8-V-3929.01-009 (4)

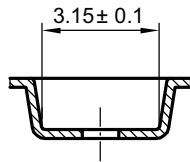
CARRIER TAPE SOT-23



A-A Section



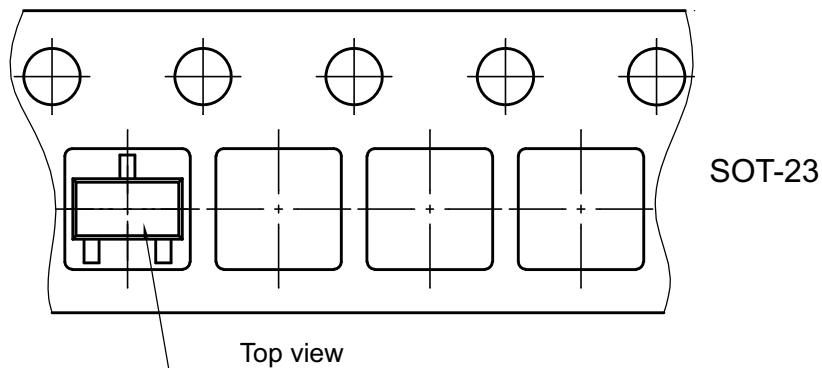
B-B Section



Created Date: 04-Feb-2010
 Rev. Date: 07-Feb-2022
 S8-V-3929.01-005 (4)

ORIENTATION IN CARRIER TAPE SOT-23

Unreeling direction →



Created Date: 04-Feb-2010
 Rev. Date: 07-Nov-2022
 S8-V-3929.01-005 (4)



Disclaimer

ALL PRODUCT, PRODUCT SPECIFICATIONS AND DATA ARE SUBJECT TO CHANGE WITHOUT NOTICE TO IMPROVE RELIABILITY, FUNCTION OR DESIGN OR OTHERWISE.

Vishay Intertechnology, Inc., its affiliates, agents, and employees, and all persons acting on its or their behalf (collectively, "Vishay"), disclaim any and all liability for any errors, inaccuracies or incompleteness contained in any datasheet or in any other disclosure relating to any product.

Vishay makes no warranty, representation or guarantee regarding the suitability of the products for any particular purpose or the continuing production of any product. To the maximum extent permitted by applicable law, Vishay disclaims (i) any and all liability arising out of the application or use of any product, (ii) any and all liability, including without limitation special, consequential or incidental damages, and (iii) any and all implied warranties, including warranties of fitness for particular purpose, non-infringement and merchantability.

Statements regarding the suitability of products for certain types of applications are based on Vishay's knowledge of typical requirements that are often placed on Vishay products in generic applications. Such statements are not binding statements about the suitability of products for a particular application. It is the customer's responsibility to validate that a particular product with the properties described in the product specification is suitable for use in a particular application. Parameters provided in datasheets and / or specifications may vary in different applications and performance may vary over time. All operating parameters, including typical parameters, must be validated for each customer application by the customer's technical experts. Product specifications do not expand or otherwise modify Vishay's terms and conditions of purchase, including but not limited to the warranty expressed therein.

Hyperlinks included in this datasheet may direct users to third-party websites. These links are provided as a convenience and for informational purposes only. Inclusion of these hyperlinks does not constitute an endorsement or an approval by Vishay of any of the products, services or opinions of the corporation, organization or individual associated with the third-party website. Vishay disclaims any and all liability and bears no responsibility for the accuracy, legality or content of the third-party website or for that of subsequent links.

Vishay products are not designed for use in life-saving or life-sustaining applications or any application in which the failure of the Vishay product could result in personal injury or death unless specifically qualified in writing by Vishay. Customers using or selling Vishay products not expressly indicated for use in such applications do so at their own risk. Please contact authorized Vishay personnel to obtain written terms and conditions regarding products designed for such applications.

No license, express or implied, by estoppel or otherwise, to any intellectual property rights is granted by this document or by any conduct of Vishay. Product names and markings noted herein may be trademarks of their respective owners.