

Description

The 74AHC126 provides provides four independent buffer gates with 3-state outputs. Each buffer has a separate enable pin that when driven with a low logic level places the corresponding output in the high-impedance state. The device is designed for operation with a power supply range of 2.0V to 5.5V. The inputs are tolerant to 5.5V allowing this device to be used in a mixed voltage environment.

Pin Assignments

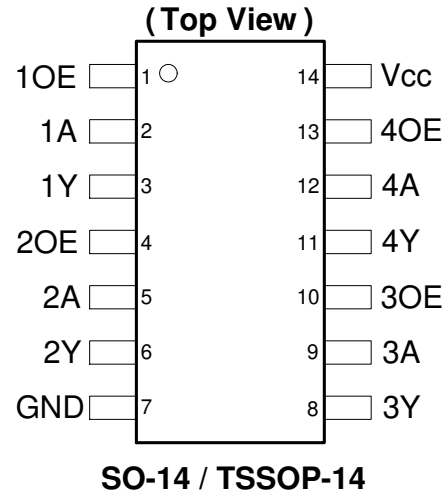

Features

- Wide Supply Voltage Range from 2.0V to 5.5V
- Outputs Sink or Source 8mA at $V_{CC} = 4.5V$
- CMOS Low Power Consumption
- Schmitt Trigger Action at All Inputs
- Inputs can be Driven by 3.3V or 5.5V Allowing for Voltage Translation Applications
- ESD Protection Exceeds JESD 22
 - 200V Machine Model (A115)
 - 2000V Human Body Model (A114)
 - Exceeds 1000V Charged Device Model (C101)
- Latch-Up Exceeds 250mA per JESD 78, Class II
- Range of Package Options SO-14 and TSSOP-14
- **Totally Lead-Free & Fully RoHS Compliant (Notes 1 & 2)**
- **Halogen and Antimony Free. "Green" Device (Note 3)**

Notes:

1. No purposely added lead. Fully EU Directive 2002/95/EC (RoHS), 2011/65/EU (RoHS 2) & 2015/863/EU (RoHS 3) compliant.
2. See <https://www.diodes.com/quality/lead-free/> for more information about Diodes Incorporated's definitions of Halogen- and Antimony-free, "Green" and Lead-free.
3. Halogen- and Antimony-free "Green" products are defined as those which contain <900ppm bromine, <900ppm chlorine (<1500ppm total Br + Cl) and <1000ppm antimony compounds.

Applications

- General Purpose Logic
- Wide Array of Products, such as:
 - PCs, Networking, Notebooks, Netbooks
 - Computer Peripherals, Hard Drives, CD/DVD ROM
 - TV, DVD, DVR, Set Top Box

Ordering Information

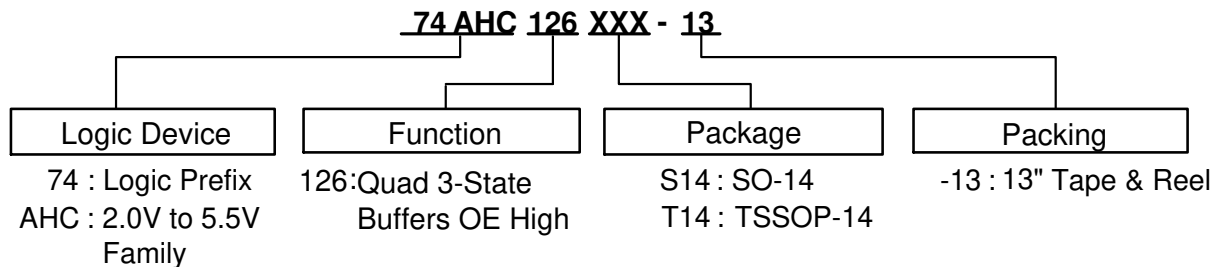

Device	Package Code	Packaging	13" Tape and Reel	
			Quantity	Part Number Suffix
74AHC126S14-13	S14	SO-14	2500/Tape & Reel	-13
74AHC126T14-13	T14	TSSOP-14	2500/Tape & Reel	-13

Pin Descriptions

Pin Number	Pin Name	Function
1	1OE	Data Enable Input (Active High)
2	1A	Data Input
3	1Y	Data Output
4	2OE	Data Enable Input (Active High)
5	2A	Data Input
6	2Y	Data Output
7	GND	Ground
8	3Y	Data Output
9	3A	Data Input
10	3OE	Data Enable Input (Active High)
11	4Y	Data Output
12	4A	Data Input
13	4OE	Data Enable Input (Active High)
14	V _{CC}	Supply Voltage

Function Table

Inputs		Output
OE	A	Y
H	H	H
H	L	L
L	X	Z

Logic Diagram

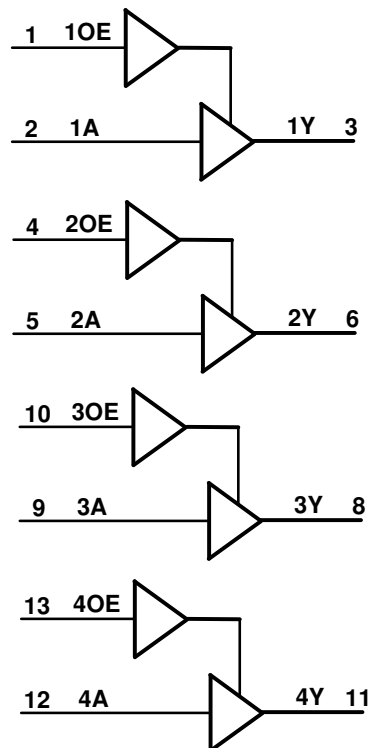

Absolute Maximum Ratings (Note 4) ($T_A = +25^\circ\text{C}$, unless otherwise specified.)

Symbol	Description	Rating	Unit
ESD HBM	Human Body Model ESD Protection	2	kV
ESD CDM	Charged Device Model ESD Protection	1	kV
ESD MM	Machine Model ESD Protection	200	V
V_{CC}	Supply Voltage Range	-0.5 to +7.0	V
V_I	Input Voltage Range	-0.5 to +7.0	V
I_{IK}	Input Clamp Current $V_I < -0.5\text{V}$	-20	mA
I_{OK}	Output Clamp Current $V_O < -0.5\text{V}$	-20	mA
I_{OK}	Output Clamp Current $V_O > V_{CC} + 0.5\text{V}$	25	mA
I_O	Continuous Output Current $-0.5\text{V} < V_O < V_{CC} + 0.5\text{V}$	± 25	mA
I_{CC}	Continuous Current Through V_{CC}	75	mA
I_{GND}	Continuous Current Through GND	-75	mA
T_J	Operating Junction Temperature	-40 to +150	$^\circ\text{C}$
T_{STG}	Storage Temperature	-65 to +150	$^\circ\text{C}$
P_{TOT}	Total Power Dissipation	500	mW

Note: 4. Stresses beyond the absolute maximum may result in immediate failure or reduced reliability. These are stress values and device operation should be within recommend values.

Recommended Operating Conditions (Note 5) ($T_A = +25^\circ\text{C}$, unless otherwise specified.)

Symbol	Parameter	Conditions	Min	Max	Unit
V_{CC}	Supply Voltage	—	2.0	5.5	V
V_I	Input Voltage	—	0	5.5	V
V_O	Output Voltage	—	0	V_{CC}	V
$\Delta t/\Delta V$	Input Transition Rise or Fall Rate	$V_{CC} = 3.0\text{V to } 3.6\text{V}$	—	100	ns/V
		$V_{CC} = 4.5\text{V to } 5.5\text{V}$	—	20	
T_A	Operating Free-Air Temperature	—	-40	+125	$^\circ\text{C}$

Note: 5. Unused inputs should be held at V_{CC} or Ground.

Electrical Characteristics

Symbol	Parameter	Test Conditions	V _{CC}	T _A = -40°C to +85°C		T _A = -40°C to +125°C		Unit
				Min	Max	Min	Max	
V _{IH}	High-Level Input Voltage	—	2.0V	1.5	—	1.5	—	V
		—	3.0V	2.1	—	2.1	—	
		—	5.5V	3.85	—	3.85	—	
V _{IL}	Low-Level Input Voltage	—	2.0V	—	0.5	—	0.5	V
		—	3.0V	—	0.9	—	0.9	
		—	5.5V	—	1.65	—	1.65	
V _{OH}	High-Level Output Voltage	I _{OH} = -50μA	2.0V	1.9	—	1.9	—	V
		I _{OH} = -50μA	3.0V	2.9	—	2.9	—	
		I _{OH} = -50μA	4.5V	4.4	—	4.4	—	
		I _{OH} = -4mA	3.0V	2.48	—	2.40	—	
		I _{OH} = -8mA	4.5V	3.80	—	3.70	—	
V _{OL}	Low-Level Output Voltage	I _{OL} = 50μA	2.0V	—	0.1	—	0.1	V
		I _{OL} = 50μA	3.0V	—	0.1	—	0.1	
		I _{OL} = 50μA	4.5V	—	0.1	—	0.1	
		I _{OL} = 4mA	3.0V	—	0.44	—	0.55	
		I _{OL} = 8mA	4.5V	—	0.44	—	0.55	
I _{OZ}	Z State Leakage Current	V _O = 0 to 5.5V V _I = GND or 5.5V	5.5V	—	±2.5	—	±10	μA
I _I	Input Current	V _I = GND to 5.5V	3.6V	—	±1	—	±2	μA
I _{CC}	Supply Current	V _I = GND or V _{CC} , I _O = 0	3.6V	—	20	—	40	μA

Operating Characteristics

Parameter		Test Conditions	V _{CC} = 2.0V	V _{CC} = 3.3V	V _{CC} = 5V	Unit
			Typ	Typ	Typ	
C _{pd}	Power Dissipation Capacitance per Gate	f = 1MHz	10.1	13.1	15	pF
C _i	Input Capacitance	V _i = V _{CC} or GND	4.0	4.0	4.0	pF

Switching Characteristics

Symbol	Parameter	Test Conditions	V _{CC}	T _A = +25°C			-40°C to +85°C		-40°C to +125°C		Unit
				Min	Typ	Max	Min	Max	Min	Max	
t _{PD}	Propagation Delay A _N to Y _N	Figure 1 C _L = 15pF	3.0V to 3.6V	0.5	4.4	8.0	0.5	9.5	0.5	11.5	ns
			4.5V to 5.5V	0.5	3.0	5.5	0.5	6.5	0.5	7.0	
		Figure 1 C _L = 50pF	3.0V to 3.6V	0.5	6.2	11.5	0.5	13.0	0.5	14.5	
			4.5V to 5.5V	0.5	4.3	7.5	0.5	8.5	0.5	9.5	
t _{EN}	Enable Time O _{EN} to Y _N	Figure 1 C _L = 15 pF	3.0V to 3.6V	0.5	4.7	8.0	0.5	9.5	0.5	11.5	ns
			4.5V to 5.5V	0.5	3.3	5.1	0.5	6.0	0.5	7.5	
		Figure 1 C _L = 50pF	3.0V to 3.6V	0.5	6.8	11.5	0.5	13.0	0.5	14.5	
			4.5V to 5.5V	0.5	4.7	7.1	0.5	8.0	0.5	9.0	
t _{DIS}	Disable Time O _{EN} to Y _N	Figure 1 C _L = 15 pF	3.0V to 3.6V	0.5	6.7	9.7	0.5	11.5	0.5	12.5	ns
			4.5V to 5.5V	0.5	4.8	6.8	0.5	8.0	0.5	8.5	
		Figure 1 C _L = 50pF	3.0V to 3.6V	0.5	9.6	13.2	0.5	15.0	0.5	16.5	
			4.5V to 5.5V	0.5	6.8	8.8	0.5	10.0	0.5	11.0	

Parameter Measurement Information

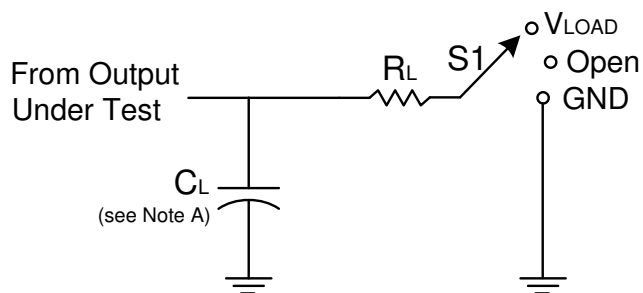

TEST	S1
t_{PLH}/t_{PHL}	Open
t_{PLZ}/t_{PZL}	Vload
t_{PHZ}/t_{PZH}	GND

V_{CC}	Inputs		V_M	V_{LOAD}	C_L	R_L	V_{Δ}
	V_I	t_r/t_f					
$3.3V \pm 0.3V$	3 V	$\leq 3ns$	$V_{CC}/2$	V_{CC}	15,50 pF	1K Ω	0.3 V
$5V \pm 0.5V$	V_{CC}	$\leq 3ns$	$V_{CC}/2$	V_{CC}	15,50 pF	1K Ω	0.3 V

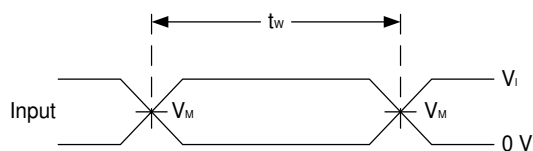

Voltage Waveform Pulse Duration

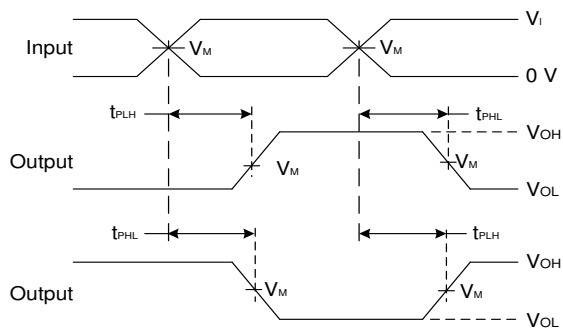

**Voltage Waveform Propagation Delay Times
Inverting and Non Inverting Outputs**

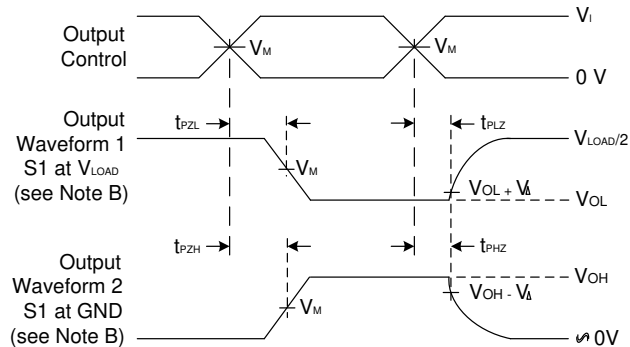

**Voltage Waveform Enable and Disable Times
Low and High Level Enabling**

Figure 1. Load Circuit and Voltage Waveforms

- Notes:
- A. Includes test lead and test apparatus capacitance.
 - B. All pulses are supplied at pulse repetition rate ≤ 1 MHz.
 - C. Inputs are measured separately one transition per measurement.
 - D. t_{PLZ} and t_{PHZ} are the same as t_{dis} .
 - E. t_{PZL} and t_{PZH} are the same as t_{EN0} .
 - F. t_{PLH} and t_{PHL} are the same as t_{PD} .

Marking Information

(1) SO-14, TSSOP-14

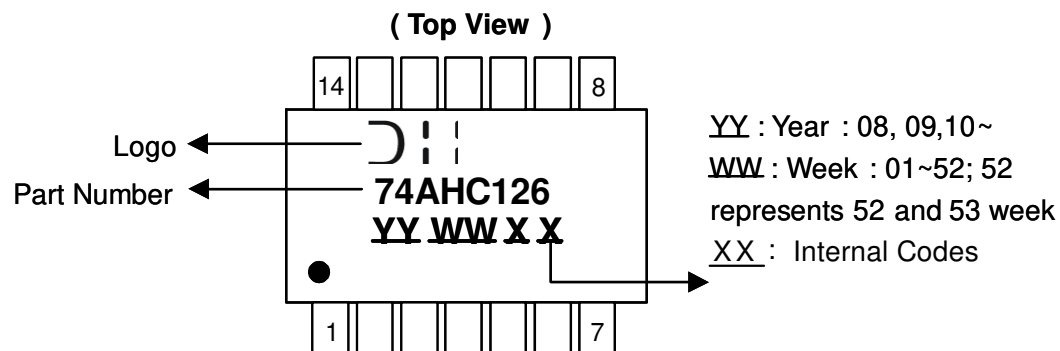

Part Number	Package
74AHC126S14	SO-14
74AHC126T14	TSSOP-14

Package Outline Dimensions (All dimensions in mm.)

Please see <http://www.diodes.com/package-outlines.html> for the latest version.

SO-14

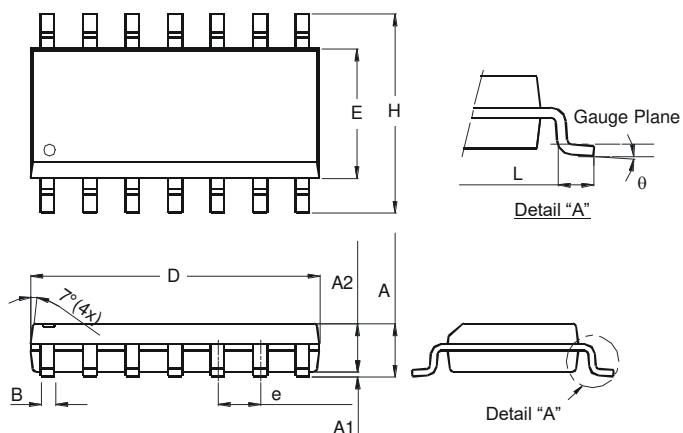

SO-14		
Dim	Min	Max
A	1.47	1.73
A1	0.10	0.25
A2	1.45 Typ	
B	0.33	0.51
D	8.53	8.74
E	3.80	3.99
e	1.27 Typ	
H	5.80	6.20
L	0.38	1.27
θ	0°	8°
All Dimensions in mm		

TSSOP-14

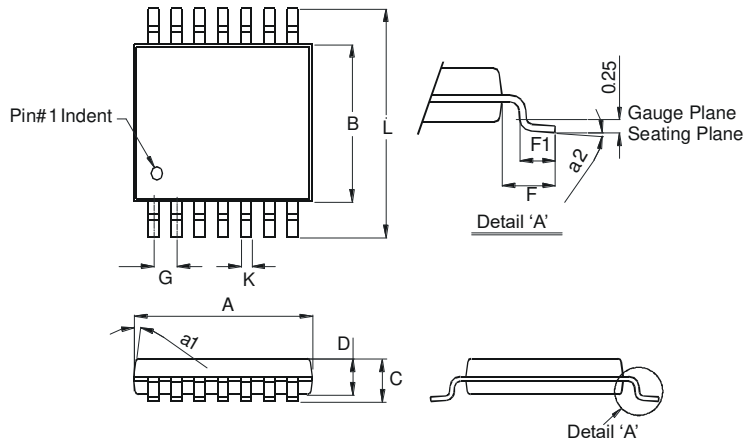

TSSOP-14		
Dim	Min	Max
a1	7° (4X)	
a2	0°	8°
A	4.9	5.10
B	4.30	4.50
C	—	1.2
D	0.8	1.05
F	1.00 Typ	
F1	0.45	0.75
G	0.65 Typ	
K	0.19	0.30
L	6.40 Typ	
All Dimensions in mm		

Suggested Pad Layout

Please see <http://www.diodes.com/package-outlines.html> for the latest version.

SO-14

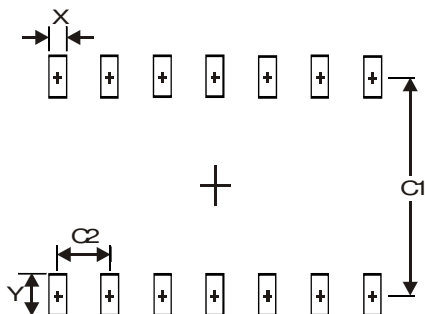

Dimensions	Value (in mm)
X	0.60
Y	1.50
C1	5.4
C2	1.27

TSSOP-14

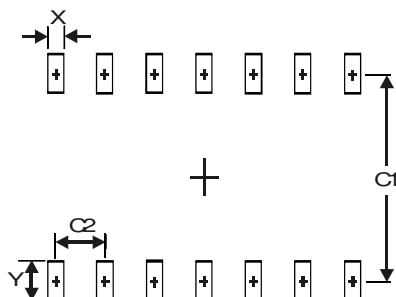

Dimensions	Value (in mm)
X	0.45
Y	1.45
C1	5.9
C2	0.65

IMPORTANT NOTICE

DIODES INCORPORATED MAKES NO WARRANTY OF ANY KIND, EXPRESS OR IMPLIED, WITH REGARDS TO THIS DOCUMENT, INCLUDING, BUT NOT LIMITED TO, THE IMPLIED WARRANTIES OF MERCHANTABILITY AND FITNESS FOR A PARTICULAR PURPOSE (AND THEIR EQUIVALENTS UNDER THE LAWS OF ANY JURISDICTION).

Diodes Incorporated and its subsidiaries reserve the right to make modifications, enhancements, improvements, corrections or other changes without further notice to this document and any product described herein. Diodes Incorporated does not assume any liability arising out of the application or use of this document or any product described herein; neither does Diodes Incorporated convey any license under its patent or trademark rights, nor the rights of others. Any Customer or user of this document or products described herein in such applications shall assume all risks of such use and will agree to hold Diodes Incorporated and all the companies whose products are represented on Diodes Incorporated website, harmless against all damages.

Diodes Incorporated does not warrant or accept any liability whatsoever in respect of any products purchased through unauthorized sales channel. Should Customers purchase or use Diodes Incorporated products for any unintended or unauthorized application, Customers shall indemnify and hold Diodes Incorporated and its representatives harmless against all claims, damages, expenses, and attorney fees arising out of, directly or indirectly, any claim of personal injury or death associated with such unintended or unauthorized application.

Products described herein may be covered by one or more United States, international or foreign patents pending. Product names and markings noted herein may also be covered by one or more United States, international or foreign trademarks.

This document is written in English but may be translated into multiple languages for reference. Only the English version of this document is the final and determinative format released by Diodes Incorporated.

LIFE SUPPORT

Diodes Incorporated products are specifically not authorized for use as critical components in life support devices or systems without the express written approval of the Chief Executive Officer of Diodes Incorporated. As used herein:

- A. Life support devices or systems are devices or systems which:
1. are intended to implant into the body, or
 2. support or sustain life and whose failure to perform when properly used in accordance with instructions for use provided in the labeling can be reasonably expected to result in significant injury to the user.
- B. A critical component is any component in a life support device or system whose failure to perform can be reasonably expected to cause the failure of the life support device or to affect its safety or effectiveness.

Customers represent that they have all necessary expertise in the safety and regulatory ramifications of their life support devices or systems, and acknowledge and agree that they are solely responsible for all legal, regulatory and safety-related requirements concerning their products and any use of Diodes Incorporated products in such safety-critical, life support devices or systems, notwithstanding any devices- or systems-related information or support that may be provided by Diodes Incorporated. Further, Customers must fully indemnify Diodes Incorporated and its representatives against any damages arising out of the use of Diodes Incorporated products in such safety-critical, life support devices or systems.

Copyright © 2019, Diodes Incorporated

www.diodes.com