

36-V Input, 3-A Synchronous Step-Down Voltage Regulator

Features

- Wide Supply Voltage: 4.5 V to 36 V
- Internal Power FET : 85 mΩ and 45 mΩ
- 0.6-V Reference Voltage with 2% Accuracy
- High-Efficiency Synchronous-Mode Operation
- Fixed Switching Frequency
 - 400 kHz (TPP363080/2)
 - 1 MHz (TPP363081/3)
- Low 2-μA Shutdown, 90-μA Quiescent Current
- Internal Light Load Power-Save Mode for High Efficiency at Light Load (TPP363080/1)
- Forced-PWM Mode for Low Output Ripple (TPP363082/3)
- Internal 2-ms Soft-start Timer
- Internal Loop Compensation
- Over-Current Protection with Hiccup Mode
- Output Over-Voltage Protection
- Thermal Shutdown
- Small Outline Package TSOT23-6
- -40°C to 125°C Operation Ambient Temperature Range

Applications

- 12-V, 24-V Distributed Power Supply
- Industrial Applications
- General Purpose

Description

The TPP36308x is a simple, easy-to-use, 3-A output, synchronous, step-down, and switch-mode converter with internal power MOSFETs.

The TPP36308x integrates low- $R_{DS(ON)}$ power transistors in the TSOT23-6 package with internal soft-start, compensation, and protection features. The TPP36308x offers a very compact solution to achieve a 3-A continuous output current over a wide input supply range, with excellent load and line regulation.

The TPP36308x has different versions of switching frequencies at 400 kHz and 1 MHz, and also supports light load PSM to save the quiescent current and forced-PWM mode to maintain fixed switching frequency.

The device is available in the 6-pin TSOT23-6 package with the support of a wide operation ambient temperature range from -40 °C to 125 °C.

Typical Application Circuit

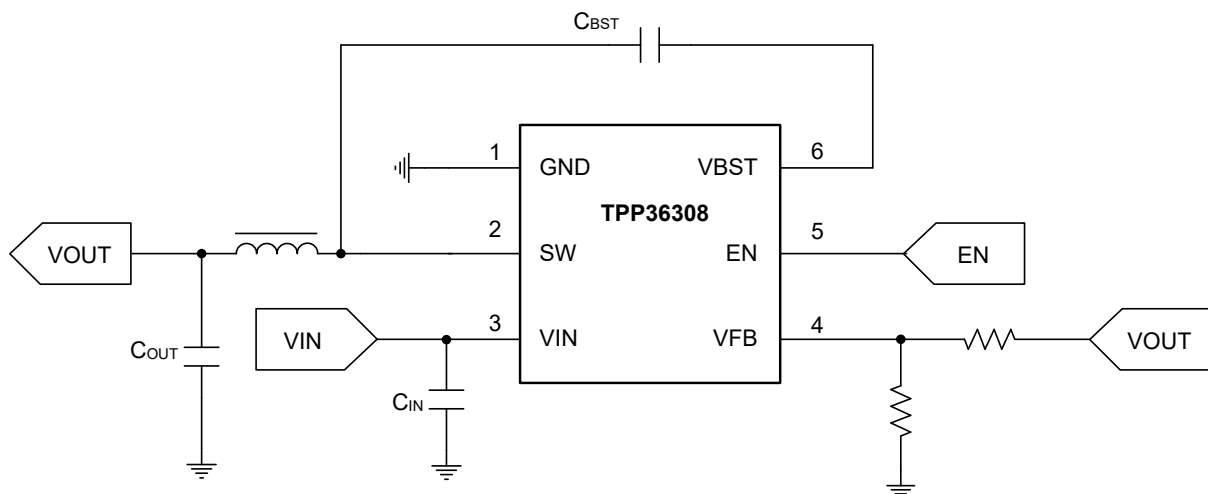

Table of Contents

Features	1
Applications	1
Description	1
Typical Application Circuit	1
Product Family Table	3
Revision History	3
Pin Configuration and Functions	4
Specifications	5
Absolute Maximum Ratings ⁽¹⁾	5
ESD, Electrostatic Discharge Protection.....	5
Recommended Operating Conditions.....	6
Thermal Information.....	6
Electrical Characteristics.....	7
Typical Performance Characteristics.....	9
Detailed Description	13
Overview.....	13
Functional Block Diagram.....	13
Feature Description.....	14
Application and Implementation	16
Application Information.....	16
Typical Application.....	16
Layout	20
Layout Example.....	20
Tape and Reel Information	21
Package Outline Dimensions	23
TSOT23-6.....	23
Order Information	24
IMPORTANT NOTICE AND DISCLAIMER	25

Product Family Table

Order Number	Switching Frequency (kHz)	Light Load Mode
TPP363080-T6TR(-S)	400 kHz	Pulse-Skip Mode
TPP363081-T6TR	1 MHz	Pulse-Skip Mode
TPP363082-T6TR	400 kHz	Forced-PWM Mode
TPP363083-T6TR	1 MHz	Forced-PWM Mode

(1) Contact 3PEAK representatives for more information.

Revision History

Date	Revision	Notes
2022-11-04	Rev.A.0	Initial release
2023-11-30	Rev.A.1	Misc. update
2024-04-18	Rev.A.2	Updated thermal resistance

Pin Configuration and Functions

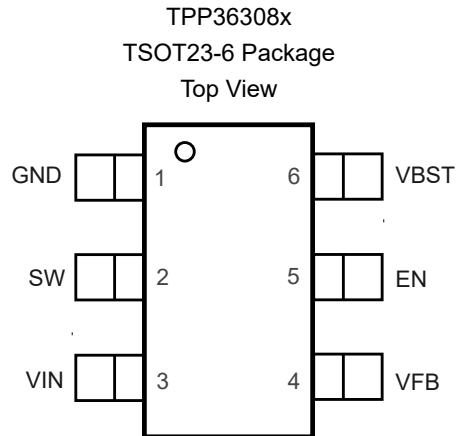

Table 1. Pin Functions: TPP36308

Pin No.	Pin Name	I/O	Description
1	GND	G	Ground pin. Power and controller circuit ground. Use star connection to the GND pin with good contact.
2	SW	O	Switching node pin. Voltage switching between the high-side FET and the low-side FET.
3	VIN	P	Supply input pin. Connect decoupling $2 \times 10\text{-}\mu\text{F}$ and $1 \times 0.1\text{-}\mu\text{F}$ capacitors between VIN and GND pins.
4	VFB	I	Voltage feedback pin. Connect to the output voltage with a feedback resistor divider.
5	EN	I	Enable input. Active high. Internal weak pull-up.
6	VBST	I	High-side MOSFET gate supply pin. Connect $0.1\text{-}\mu\text{F}$ between VBST and SW pins.

36-V Input, 3-A Synchronous Step-Down Voltage Regulator
Specifications
Absolute Maximum Ratings ⁽¹⁾

Parameter		Min	Max	Unit
V _{IN}	Supply Voltage	-0.3	42	V
SW	Switching Node Voltage	-0.3	V _{IN} + 0.3	V
SW	Switching Node Voltage, 20ns	-5	42	V
SW	Switching Node Voltage, 50ns	-3	42	V
VBST-SW	Bootstrap Voltage	-0.3	6	V
FB	Feedback Voltage	-0.3	6	V
EN	Enable Input	-0.3	42	V
T _J	Maximum Junction Temperature		150	°C
T _A	Operating Temperature Range	-40	125	°C
T _{STG}	Storage Temperature Range	-65	150	°C
T _L	Lead Temperature (Soldering 10 sec)		260	°C

- (1) Stresses beyond those listed under Absolute Maximum Ratings may cause permanent damage to the device. Exposure to any Absolute Maximum Rating condition for extended periods may affect device reliability and lifetime.
- (2) The inputs are protected by ESD protection diodes to each power supply. If the input extends more than 300 mV beyond the power supply, the input current should be limited to less than 10 mA.
- (3) A heat sink may be required to keep the junction temperature below the absolute maximum. This depends on the power supply voltage and how many amplifiers are shorted. Thermal resistance varies with the amount of PC board metal connected to the package. The specified values are for short traces connected to the leads.

ESD, Electrostatic Discharge Protection

Parameter		Condition	Minimum Level	Unit
HBM	Human Body Model ESD	ANSI/ESDA/JEDEC JS-001 ⁽¹⁾	2	kV
CDM	Charged Device Model ESD	ANSI/ESDA/JEDEC JS-002 ⁽²⁾	1.5	kV

- (1) JEDEC document JEP155 states that 500-V HBM allows safe manufacturing with a standard ESD control process.
- (2) JEDEC document JEP157 states that 250-V CDM allows safe manufacturing with a standard ESD control process.

36-V Input, 3-A Synchronous Step-Down Voltage Regulator**Recommended Operating Conditions**

Parameter		Min	Max	Unit
V _{IN}	Supply Voltage	4.5	36	V
V _{EN}	Enable Input Voltage	0	36	V
V _{FB}	Feedback Input Voltage	0	5.5	V
V _{BST} —V _{SW}	Bootstrap Voltage	0	5.5	V
V _{SW}	Switching Node Voltage	0	V _{IN}	V
T _J	Operating Junction Temperature	-40	150	°C

Thermal Information

Package Type	θ_{JA}	θ_{JB}	θ_{JC}	Unit
TSOT23-6	99.6	15.53	44.7	°C/W

36-V Input, 3-A Synchronous Step-Down Voltage Regulator
Electrical Characteristics

 All test conditions: $V_{IN} = 12\text{ V}$, $T_A = -40^\circ\text{C}$ to $+125^\circ\text{C}$, unless otherwise noted.

Symbol	Parameter	Conditions	Min	Typ	Max	Unit
Power Supply						
V_{IN}	Supply Voltage Range		4.5		36	V
I_Q	Operating Supply Current	Non-switching, $EN = 5\text{ V}$, $V_{FB} = 1\text{ V}$		90		μA
I_{QSD}	Shutdown Supply Current	$EN = \text{GND}$		2		μA
V_{UVLO_rising}	UVLO Rising Threshold		3.9	4.2	4.4	V
$V_{UVLO_falling}$	UVLO Falling Threshold		3.7	3.8	4.1	V
Enable						
V_{ENH}	EN Input Rising Threshold			1.28	1.35	V
V_{ENL}	EN Input Falling Threshold		1	1.17		V
I_{EN_L}	EN Current, $EN = L$	$V_{EN} = 0.9\text{ V}$	0.65	1.04	1.5	μA
I_{EN_H}	EN Current, $EN = H$	$V_{EN} = 1.5\text{ V}$	3.6	4.3	5.2	μA
I_{EN_HYS}	EN Hysteresis Current	$V_{EN} = 1.5\text{ V}$		3.3		μA
Feedback and Power Stage						
V_{FB}	V_{FB} Feedback Voltage		588	600	612	mV
$R_{ds(on)_HSD}$	High-side FET On-resistance	$I_{SW} = 1\text{ A}$		85		$\text{m}\Omega$
$R_{ds(on)_LSD}$	Low-side FET On-resistance	$I_{SW} = 1\text{ A}$		45		$\text{m}\Omega$
f_{SW}	Switching Frequency	TPP363080/2	350	400	450	kHz
		TPP363081/3		1		MHz
t_{ss}	Soft-start Time			2		ms
t_{ss_done}	Soft start Transition Time		14	18	24	ms
I_{skip}	Pulse-skip Mode Peak Inductor Current Threshold	$V_{IN} = 12\text{ V}$, $V_{OUT} = 5\text{ V}$, $L = 10\text{ }\mu\text{H}$		500		mA
Current Limit						
I_{Limit_HS}	High-side Current Limit	Inductor peak current	4	4.9	5.6	A
I_{Limit_LS}	Low-side Current Limit	Inductor valley current	2.9	3.7	4.8	A
$I_{Limit_LS_neg}$	Negative Low-side Current Limit		0.68	1	1.94	A
Diagnostics and Protection						
$V_{FB_UVP_rising}$	FB Hiccup Protection Rising Ratio			33		%
$V_{FB_UVP_falling}$	FB Hiccup Protection Falling Ratio			40		%
$V_{FB_OVP_rising}$	FB Over-voltage Protection Rising Ratio			108		%

36-V Input, 3-A Synchronous Step-Down Voltage Regulator

Symbol	Parameter	Conditions	Min	Typ	Max	Unit
V _{FB_OVP_falling}	FB Over-voltage Protection Falling Ratio			107		%
t _{HIC_wait}	Hiccup Protection Wait Time			128		Cycles
t _{HIC_restart}	Hiccup Protection Restart Time			60		ms
Thermal Shutdown						
T _{SD}	Thermal Shutdown Temperature			160		°C
T _{SD_hys}	Thermal Hysteresis			10		°C

36-V Input, 3-A Synchronous Step-Down Voltage Regulator

Typical Performance Characteristics

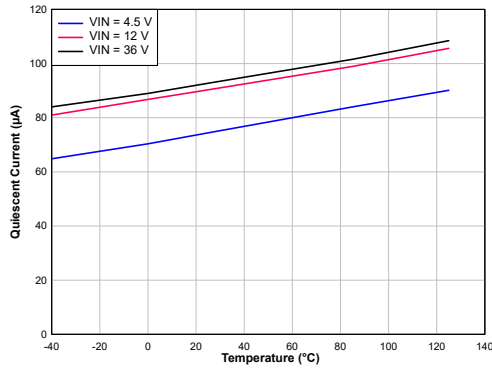

Figure 1. Quiescent Current vs. Supply Voltage

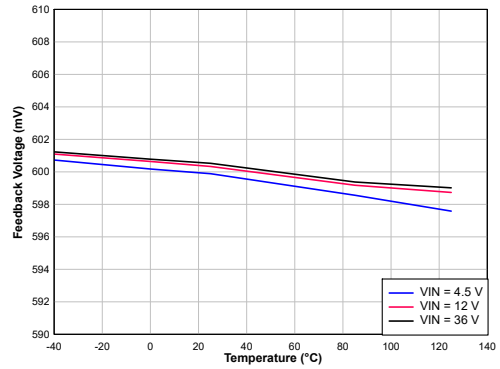

Figure 2. Reference Voltage vs. Junction Temperature

$V_{IN} = 12\text{ V}$

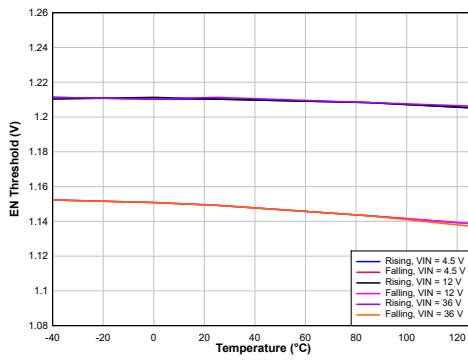

Figure 3. EN Threshold vs. Junction Temperature

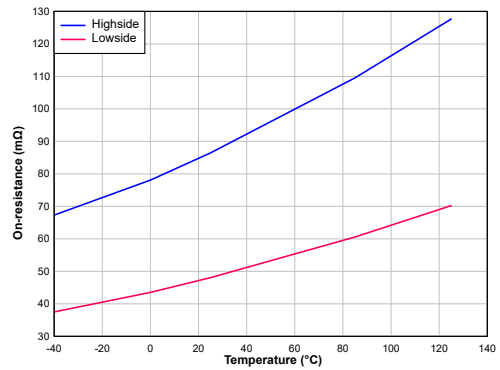

Figure 4. On-Resistance vs Temperature

$V_{IN} = 12\text{ V}, I_{OUT} = 0.5\text{ A}$

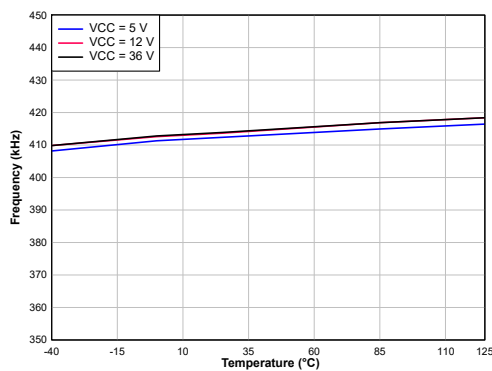

Figure 5. Switching Frequency vs. Temperature

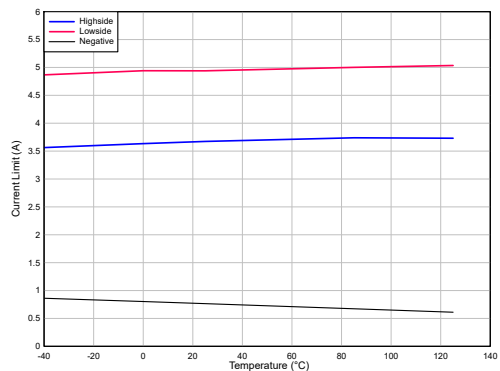

Figure 6. Current Limit vs. Temperature

36-V Input, 3-A Synchronous Step-Down Voltage Regulator

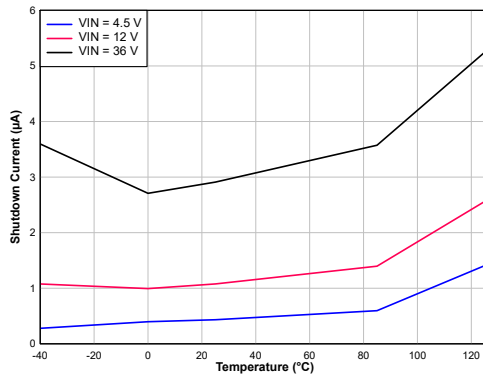

Figure 7. Shutdown Current vs Junction Temperature

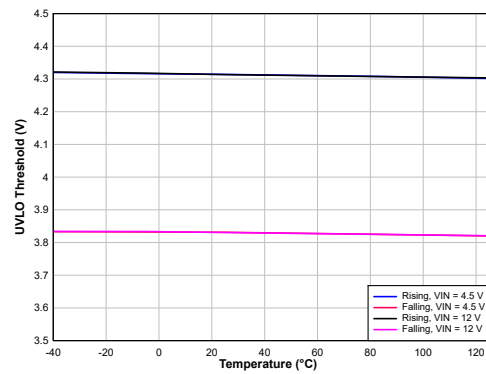

Figure 8. UVLO Threshold vs Temperature

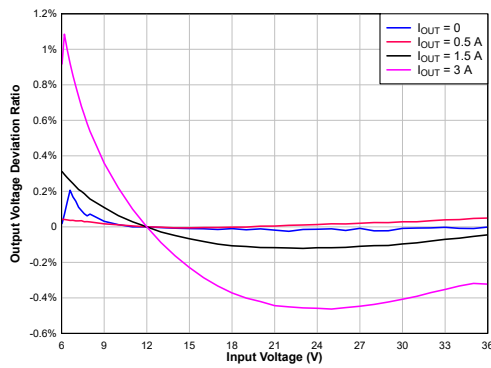

Figure 9. Load Regulation

$V_{OUT} = 5\text{ V}$

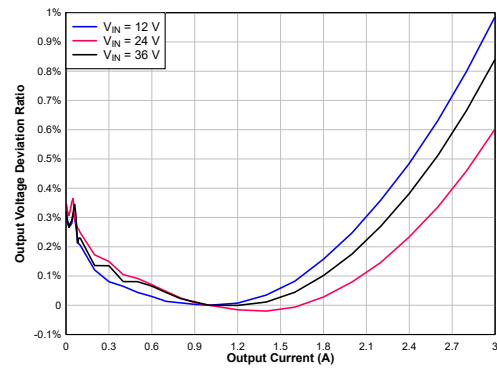

Figure 10. Line Regulation

$V_{OUT} = 5\text{ V}$

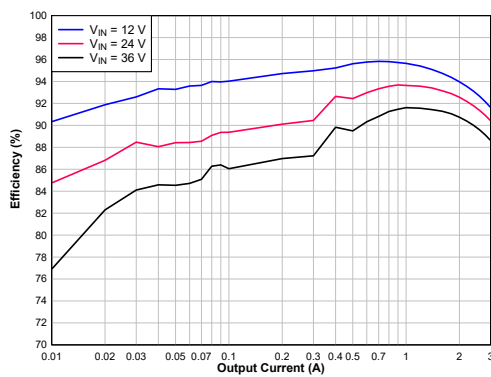

Figure 11. Efficiency vs. Output Current

$V_{OUT} = 5\text{ V}$, $L = 2.2\ \mu\text{H}$, 400kHz, TPP363080 with Pulse Skip Mode

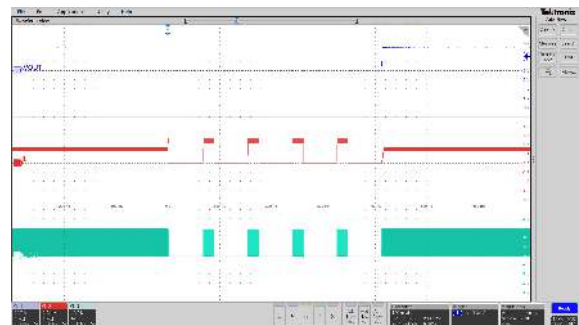
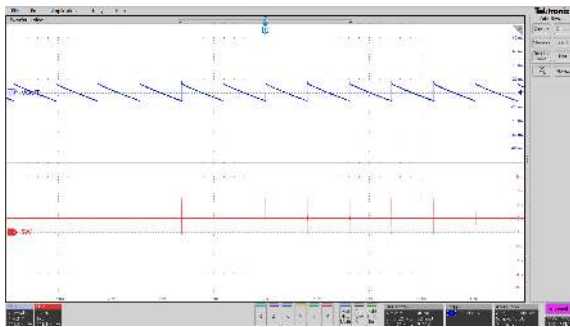

Figure 12. Hiccup Protection

$V_{OUT} = 5\text{ V}$, $L = 2.2\ \mu\text{H}$, 400kHz,

36-V Input, 3-A Synchronous Step-Down Voltage Regulator

Figure 13. Pulse Skip Mode Output Voltage Ripple

CH2: SW, CH3: V_{OUT} Ripple
 $V_{IN} = 12\text{ V}$, $V_{OUT} = 5\text{ V}$, $I_{LOAD} = 0\text{ A}$

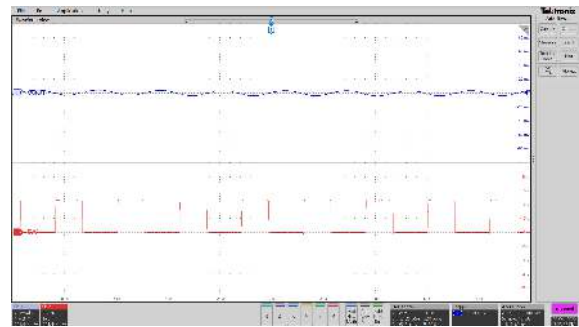
Figure 14. Output Voltage Ripple

CH2: V_{OUT} Ripple, CH3: SW
 $V_{IN} = 12\text{ V}$, $V_{OUT} = 5\text{ V}$, $I_{LOAD} = 1.5\text{ A}$

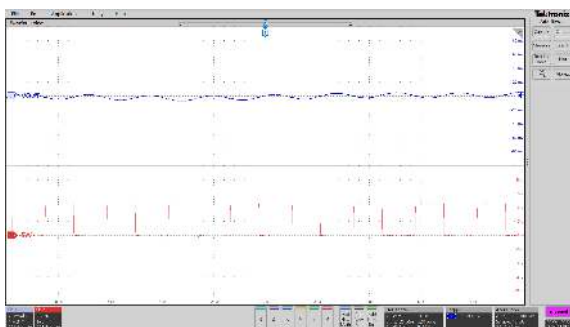
Figure 15. Output Voltage Ripple

CH2: V_{OUT} , CH3: SW
 $V_{IN} = 12\text{ V}$, $V_{OUT} = 5\text{ V}$, $I_L = 3\text{ A}$

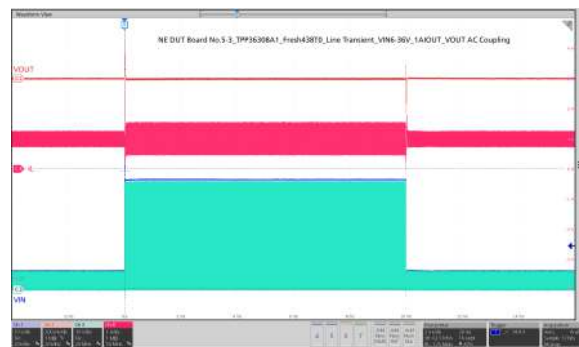
Figure 16. Line Transient

CH2: V_{OUT} , CH3: SW
 $V_{IN} = 12\text{ V}$, $V_{OUT} = 5\text{ V}$, $I_L = 1.5\text{ A}$

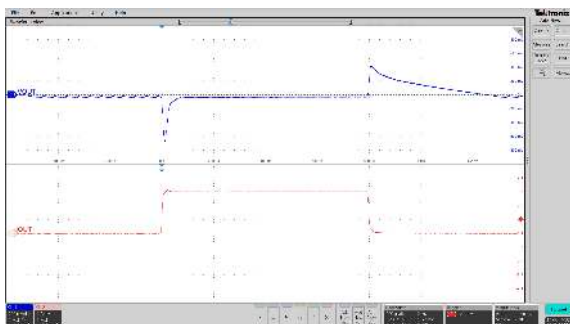
Figure 17. Load Transient

CH2: V_{OUT} , CH4: Load Current
 $V_{IN} = 12\text{ V}$, $V_{OUT} = 5\text{ V}$, $I_L = 0\text{ A}$ to 3 A

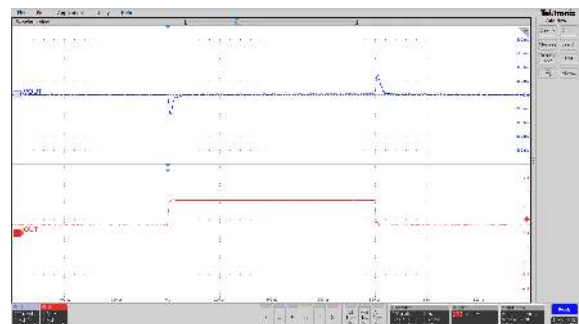
Figure 18. Line Transient

CH2: V_{OUT} , CH4: Load Current
 $V_{IN} = 12\text{ V}$, $V_{OUT} = 5\text{ V}$, $I_L = 0.6\text{ A}$ to 2.4 A

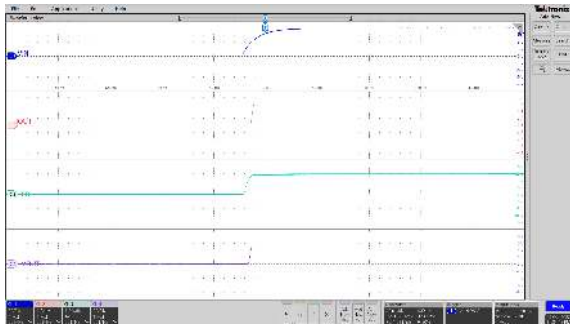
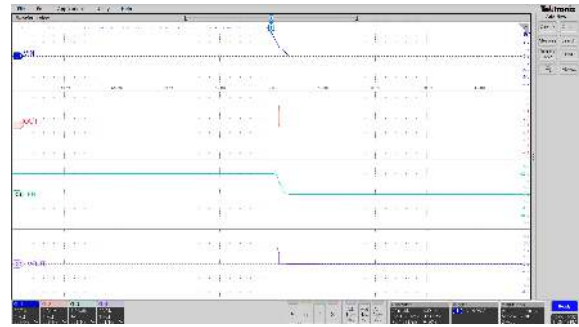
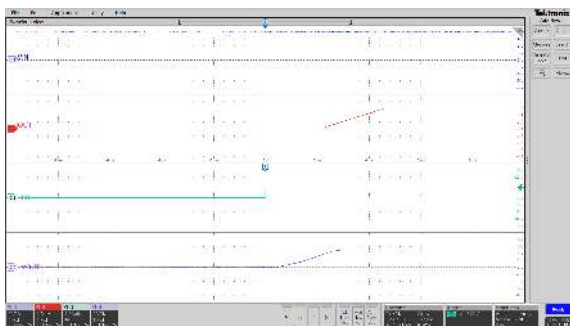
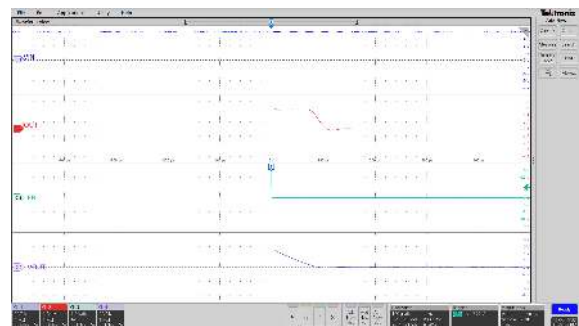
36-V Input, 3-A Synchronous Step-Down Voltage Regulator**Figure 19. Start Up by VIN**CH1: V_{IN} , CH4: EN, CH8: V_{OUT} **Figure 20. Power-Down by VIN**CH1: V_{IN} , CH4: EN, CH8: V_{OUT} **Figure 21. Start Up by EN**CH1: V_{IN} , CH4: EN, CH8: V_{OUT} **Figure 22. Power-Down by EN**CH1: V_{IN} , CH4: EN, CH8: V_{OUT}

Detailed Description

Overview

The TPP36308x is a 3-A synchronous step-down converter. The current mode control topology provides a fast transient response and supports low ESR output capacitors, such as specialty polymer capacitors and multi-layer ceramic capacitors, without extra compensation circuitry.

Device	Frequency	Low Output Current Mode
TPP363080-T6TR(-S)	400 kHz	Pulse-skip Mode
TPP363081-T6TR	1 MHz	Pulse-skip Mode
TPP363082-T6TR	400 kHz	Forced-PWM Mode
TPP363083-T6TR	1 MHz	Forced-PWM Mode

Functional Block Diagram

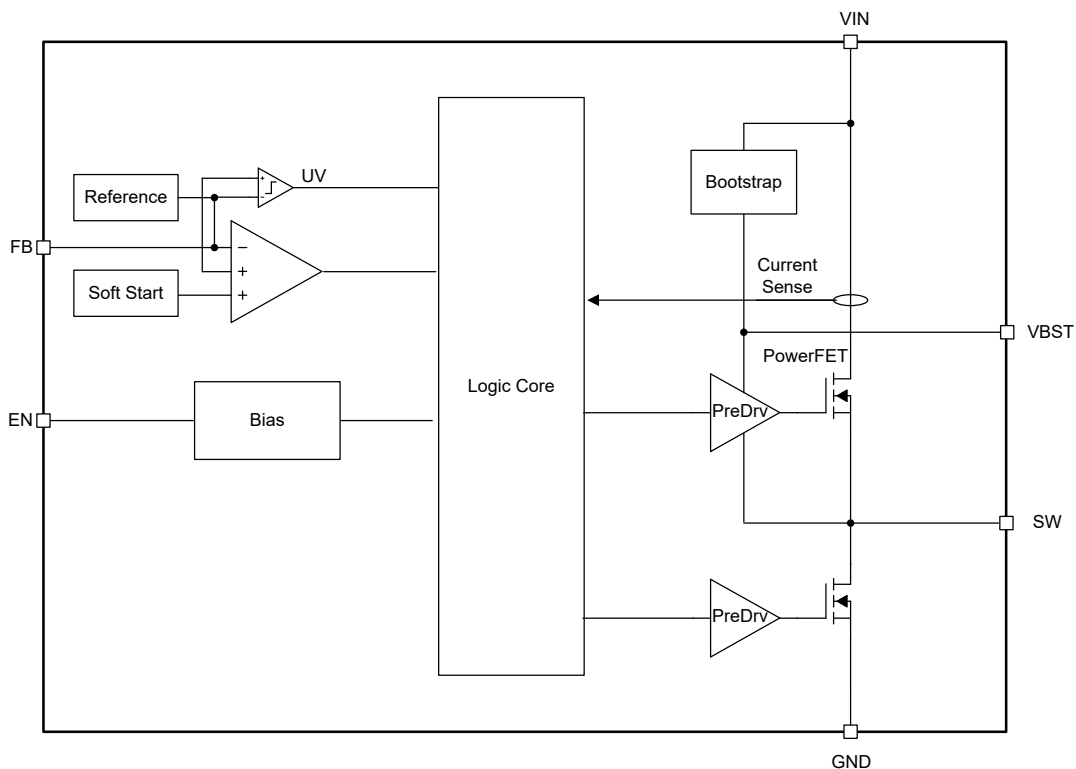

Figure 23. Functional Block Diagram

Feature Description

Current Mode Control

The TPP36308x uses the current mode control topology. The current mode topology supports fixed frequency operation thus optimizing ripple performance. With integrated low $R_{ds(on)}$, the device can achieve high efficiency in a small physical footprint.

Switching Frequency

TPP36308x supports both 400-kHz(TPP363080/TPP363082) and 1-MHz switching frequency(TPP363081/TPP363083). 400-kHz has better efficiency due to less switching loss, 1-MHz supports high frequency inductor with small form factor. 3PEAK recommends to evaluate thermal performance in 1-MHz especially at high temperature conditions.

Pulse-skip Mode

To improve light-load efficiency, the TPP363080/1 will automatically enter improved light-load mode when the inductor ripple valley current reaches zero. The controller keeps the on-time of the high-side switch unchanged. With the light load, the voltage decay takes longer time and lowers the switching frequency accordingly.

Forced-PWM Mode

The TPP363082/3 has a forced-PWM mode to support low-noise applications. When the inductor ripple valley current reaches zero, the device will automatically enter the forced-PWM mode with a fixed switching frequency. In this mode, the negative current limit of low-side FET is enabled.

Enable Input

The device EN has two current sources to pull EN up high. I_{EN} and I_{HYS} . When EN is low, the I_{EN} is enabled as I_{EN_L} . When EN rises above the threshold and turns hysteresis current I_{EN_SYSON} , the total current is I_{EN_H}

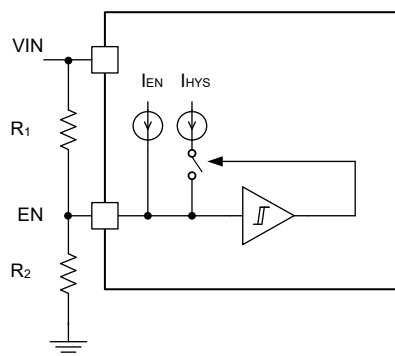

Figure 24. EN Block Diagram

The EN threshold can be set via below equations

$$R_1 = \frac{V_{ENL}(V_{IN_START} - V_{ENH}) - V_{ENH}(V_{IN_STOP} - V_{ENL})}{V_{ENH} I_{ENH} - V_{ENL} I_{ENL}}$$

$$R_2 = \frac{V_{ENH}}{I_{ENL} + \frac{V_{IN_START} - V_{ENH}}{R_1}}$$

36-V Input, 3-A Synchronous Step-Down Voltage Regulator**Soft-Start with Pre-biased Capability**

Once EN becomes high, the device ramps up its internal reference voltage with a fixed 2-ms rising time. When the output capacitor is pre-charged, the soft-start ramp will only enable output switching after the internal reference ramps above the FB voltage.

Over-Current Protection

The device has a cycle-by-cycle current limit. During the OFF state, once overcurrent is detected at the ripple current valley by measuring the low-side FET current, the device keeps the low-side FET OFF until the current falls below the over-current protection (OCP) threshold. The device has negative current and can block reverse current when reverse inductor current is higher than threshold.

Output Undervoltage Hiccup Protection

When the device output voltage falls below the hiccup voltage threshold, the device turns into the hiccup mode by turning off the device and restarts after the hiccup timer (typically 60 ms) expires.

To support large output capacitance as large as 1 mF, the device has an extended soft start transition timer. Upon power up, the device gets into soft-start and prevents the device into output under voltage hiccup protection mode until soft start transition time t_{ss_done} is over.

Undervoltage Lockout (UVLO) Protection

Once the input voltage falls below the UVLO threshold, the device is shut off. Once the device recovers above the UVLO threshold, the device returns to normal operation.

Over-Temperature Shutdown

Once the junction temperature rises across the internal over-temperature shutdown threshold, the device shuts off and recovers when the temperature falls below the threshold with hysteresis.

Application and Implementation

Note

Information in the following application sections is not part of the 3PEAK's component specification and 3PEAK does not warrant its accuracy or completeness. 3PEAK's customers are responsible for determining suitability of components for their purposes. Customers should validate and test their design implementation to confirm system functionality.

Application Information

As an easy-to-use step-down voltage regulator, also known as a buck regulator, the TPP36308x usually covers a higher input voltage to the desired output voltage set by the VFB resistor divider. The maximum output current is 3 A. The below section depicts a simplified design flow of circuitry for the TPP36308x.

Typical Application

In most 12-V systems, lower voltage rail such as 5 V/3.3 V is a typical need for microcontrollers, I/Os, and other low-voltage components. The application below lists the typical schematic for a 5-V buck regulator.

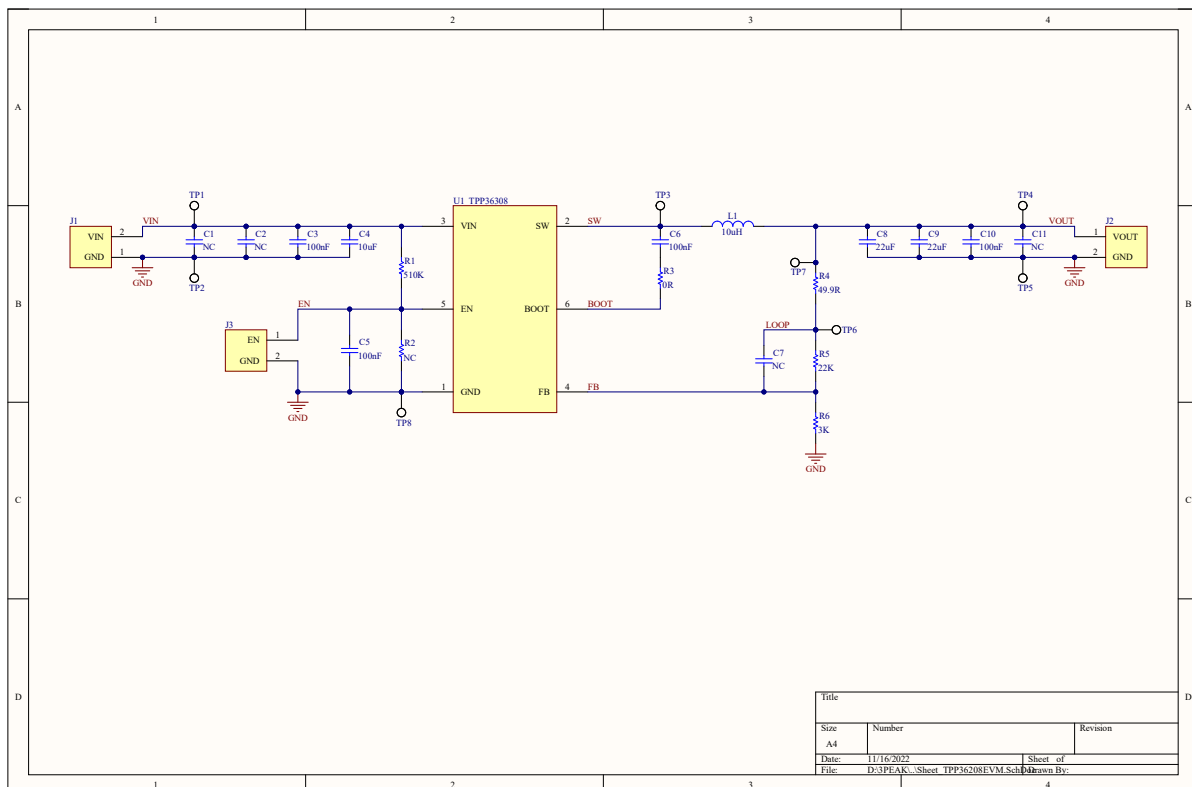

The following steps provide how to design a buck solution for TPP363080 based on the above.

1. To establish the desired output voltage (VOUT), employ Equation 1 and proceed with the selection of the resistor divider (RHS/RLs).

36-V Input, 3-A Synchronous Step-Down Voltage Regulator

$$R_{HS} = R_{LS} \left(\frac{V_{OUT}}{0.6} - 1 \right) \quad (1)$$

2. For the selection of the output inductor (LO), determine the minimum value (LO_MIN) by applying the equations below:

$$I_{RIPPLE} = \frac{V_{OUT} (V_{IN_MAX} - V_{OUT})}{V_{IN_MAX} L_O f_{SW}} \quad (2)$$

$$L_{O_MIN} = \frac{V_{OUT} (V_{IN_MAX} - V_{OUT})}{V_{IN_MAX} f_{SW} I_{OUT} r} \quad (3)$$

$$I_{LO_RMS} = \sqrt{I_{OUT}^2 + \frac{I_{RIPPLE}^2}{12}} \quad (4)$$

$$I_{LO_PEAK} = I_{OUT} + \frac{I_{RIPPLE}}{2} \quad (5)$$

Where V_{IN_MAX} represents the maximum input voltage, r denotes the ratio between the inductor ripple current (I_{RIPPLE}) and the maximum output current (I_{OUT}), I_{LO_RMS} signifies the RMS inductor current, and I_{LO_PEAK} represents the peak inductor current. Typically, a value of 0.3 is chosen when utilizing low ESR output capacitors. For the TPP363080 with an f_{SW} of 400 kHz, we recommend selecting an inductor with $I_{OUT} = 3$ A and $r = 0.3$, regardless of the operating conditions.

For example, when $V_{IN_MAX} = 36$ V and $V_{OUT} = 5$ V, the minimum value of the output inductor (L_{LO_MIN}) is calculated to be approximately 12 μ H. In this case, a standard inductor with a rating of 10 μ H, a saturation current of 5A, and a rated current of 4.3 A would be suitable.

3. Choose the Output Capacitor (C_{OUT})

$$C_{O_MIN} \geq \frac{2\Delta I_{OUT}}{f_{SW} \Delta V_{OUT}} \quad (6)$$

$$C_{O_MIN} \geq L_O \frac{I_{Oi}^2 - I_{Of}^2}{V_f^2 - V_i^2} \quad (7)$$

$$\Delta I_{OUT} = I_{Oi} - I_{Of} \quad (8)$$

$$C_{O_MIN} \geq \frac{I_{RIPPLE}}{8f_{SW} V_{O_RIPPLE}} \quad (9)$$

$$R_{ESR} \leq \frac{V_{O_RIPPLE}}{I_{RIPPLE}} \quad (10)$$

$$I_{CO_RMS} \geq \frac{V_{OUT} \times (V_{IN_MAX} - V_{OUT})}{\sqrt{12} V_{IN_MAX} L_O f_{SW}} \quad (11)$$

Where ΔI_{OUT} represents the change in output current, I_{Oi} signifies the heavy load output current, and I_{Of} represents the light load output current during load transient. ΔV_{OUT} denotes the allowable change in output voltage, while V_i represents the initial output voltage and V_f represents the maximum allowable output voltage during the transient from light load to heavy load. V_{O_RIPPLE} represents the maximum allowable value of output voltage ripple under maximum output current conditions. R_{ESR} indicates the equivalent series resistance of the output capacitor, and I_{CO_RMS} represents the RMS current of the output capacitor.

As an example, let's consider $V_{OUT} = 5$ V, $\Delta I_{OUT} = 2.5$ A - 1.5 A = 1 A, $V_{O_RIPPLE} < 50$ mV, and $\Delta V_{OUT} < 250$ mV. In this case, a minimum output capacitance of approximately 26 μ F with an ESR of less than 35 m Ω is calculated. Therefore, with capacitance derating in consideration, 2 * 22 μ F ceramic capacitors rated at 25 V with an ESR of 5 m Ω will be used.

4. Choosing the Bootstrap Capacitor (C_{BST})

To ensure proper operation of the TPP363080 device, a 0.1 μ F ceramic capacitor should be connected between the BOOT and SW pins. It is recommended to use a ceramic capacitor with X5R or superior grade dielectric and a voltage rating of 10 V or higher.

5. Choosing the Input Capacitor (C_{IN})

36-V Input, 3-A Synchronous Step-Down Voltage Regulator

To ensure proper operation of the TPP363080 device, it is necessary to connect a 10- μ F capacitor between the VIN and GND pins with a short PCB trace. It is recommended to use a ceramic capacitor with X5R or superior grade dielectric and a voltage rating of 50 V or higher. Additionally, it is common to include a 0.1 μ F, 50 V decoupling ceramic capacitor as an input capacitor.

36-V Input, 3-A Synchronous Step-Down Voltage Regulator

Comment	EVM1: F _{sw} = 400 kHz, MODE = PFM, I _{OUT} = 3 A, SS = 2 ms, V _{OUT} = 5 V					
Designator	Value	Qty.	Part No.	Package	Manufacturer	Description
U1	TPP363080	1	TPP363080-T6TR	SOT23-6	3PEAK	Buck Converter, 36 V, 3 A, 400 kHz, PFM
C1	NC	0				
C2	NC	0				
C3	100 nF	1	GGD21BR71H104KA02	0805	muRata	Capacitor, 100 nF, 50VDC, X7R, ±15%
C4	10 µF	1	GCM32EC71H106MA03L	1210	muRata	Capacitor, 10 µF, 50VDC, X7S, ±22%
R1	510 K	1	ARG03FTC5103	0603	Viking	Resistor, 510 K, ±1%, 0.1 W
C5	NC	0				
R2	100 K	1	ARG03FTC1003	0603	Viking	Resistor, 100 K, ±1%, 0.1 W
C6	100 nF	1	GRM188R71C104KA01D	0603	muRata	Capacitor, 100 nF, 16VDC, X7R, ±15%
C7	NC	0				
R3	0 R	1	ERJ-3GEY0R00V	0603	Panasonic	Resistor, 0 Ω, 5%, 0.1 W
L1	10 µH	1	7447714100	10mm×5mm×10mm	Würth Elektronik eiSos	Inductor, 10 µH, 4.3 A, 23 ohm, ±20%
C8	22 µF	1	GRM32ER71E226ME15L	1210	muRata	Capacitor, 22 µF, 25 VDC, X7R, ±15%
C9	22 µF	1	GRM32ER71E226ME15L	1210	muRata	Capacitor, 22 µF, 25 VDC, X7R, ±15%
C10	100 nF	1	GGD21BR71H104KA02	0805	muRata	Capacitor, 100 nF, 50 VDC, X7R, ±15%
C11	NC	0				
R4	49.9 R	1	ARG03FTC49R9	0603	Viking	Resistor, 49.9 Ω, ±1%, 0.1 W
R5	22 K	1	ARG03FTC2202	0603	Viking	Resistor, 22 K, ±1%, 0.1 W
R6	3 K	1	ARG03FTC3001	0603	Viking	Resistor, 3 K, ±1%, 0.1 W

Layout

Layout Example

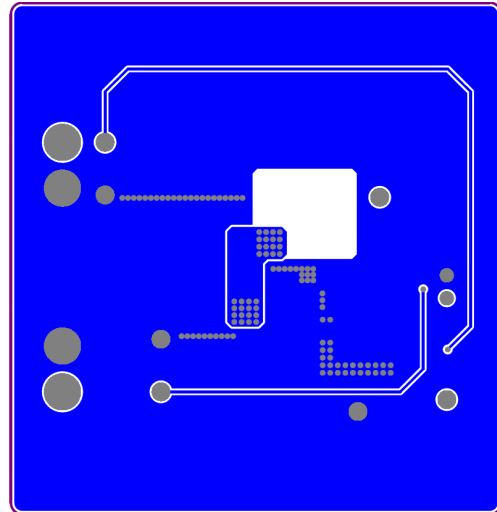
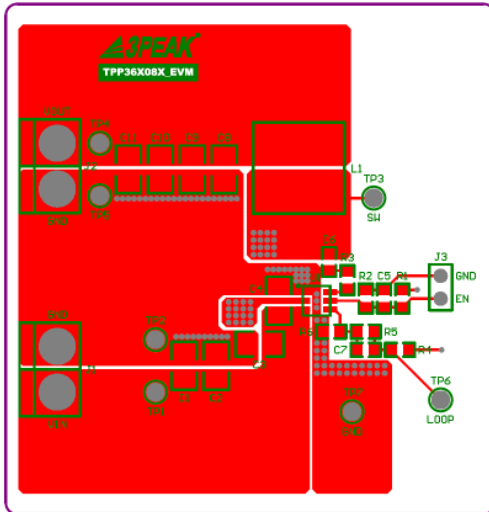

Tape and Reel Information

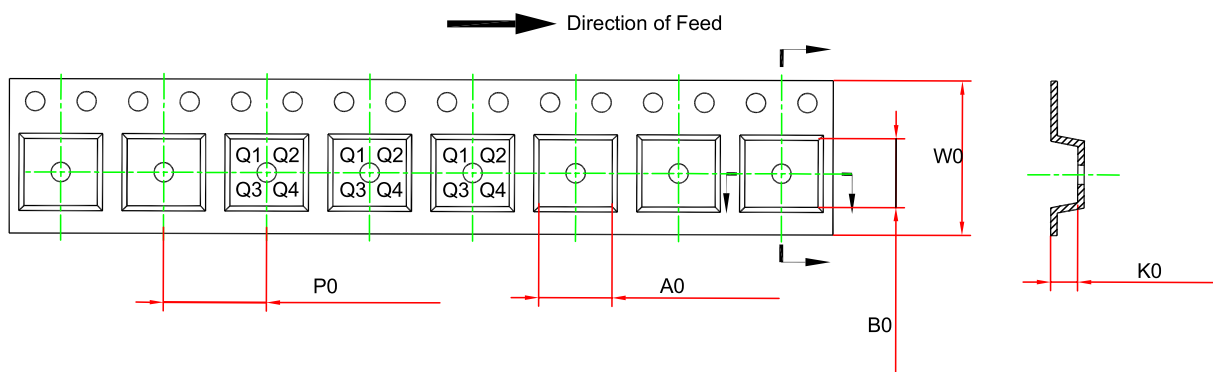
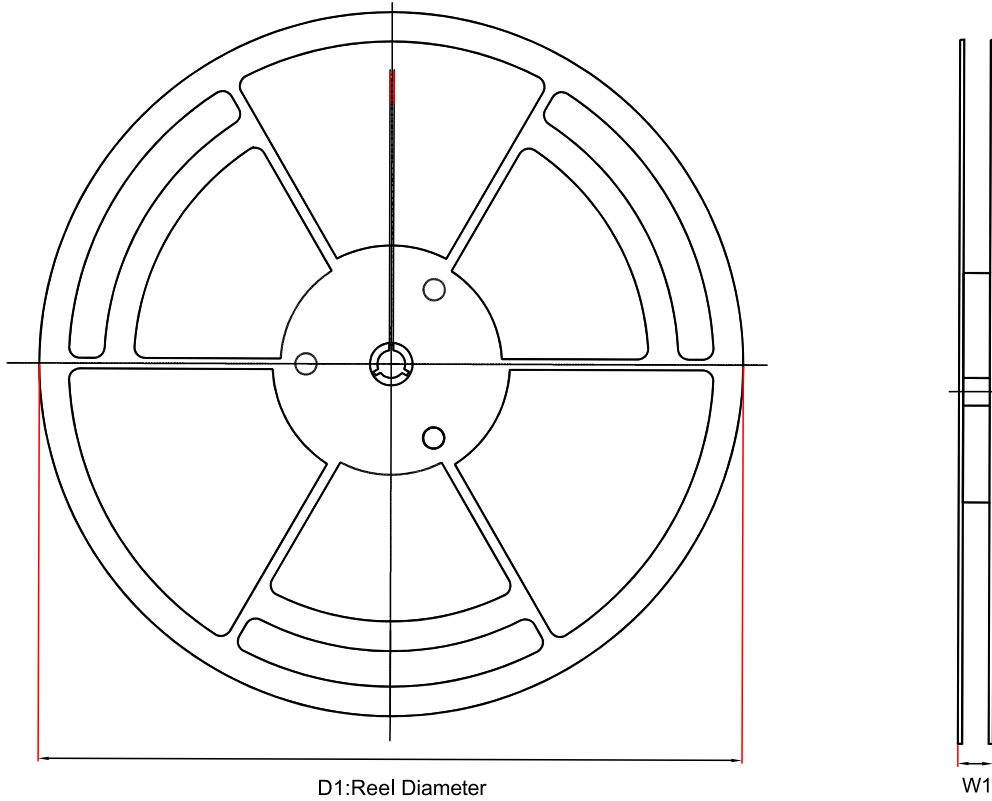

Order Number	Package	D1 (mm)	W1 (mm)	A0 (mm)	B0 (mm)	K0 (mm)	P0 (mm)	W0 (mm)	Pin1 Quadrant
TPP363080-T6TR	TSOT23-6	178.0	12.3	3.2	3.05	1.1	4.0	8.0	Q3
TPP363080-T6TR-S	TSOT23-6	178.0	12.3	3.2	3.05	1.1	4.0	8.0	Q3
TPP363081-T6TR	TSOT23-6	178.0	12.3	3.2	3.05	1.1	4.0	8.0	Q3

36-V Input, 3-A Synchronous Step-Down Voltage Regulator

Order Number	Package	D1 (mm)	W1 (mm)	A0 (mm)	B0 (mm)	K0 (mm)	P0 (mm)	W0 (mm)	Pin1 Quadrant
TPP363082- T6TR	TSOT23-6	178.0	12.3	3.2	3.05	1.1	4.0	8.0	Q3
TPP363083- T6TR	TSOT23-6	178.0	12.3	3.2	3.05	1.1	4.0	8.0	Q3

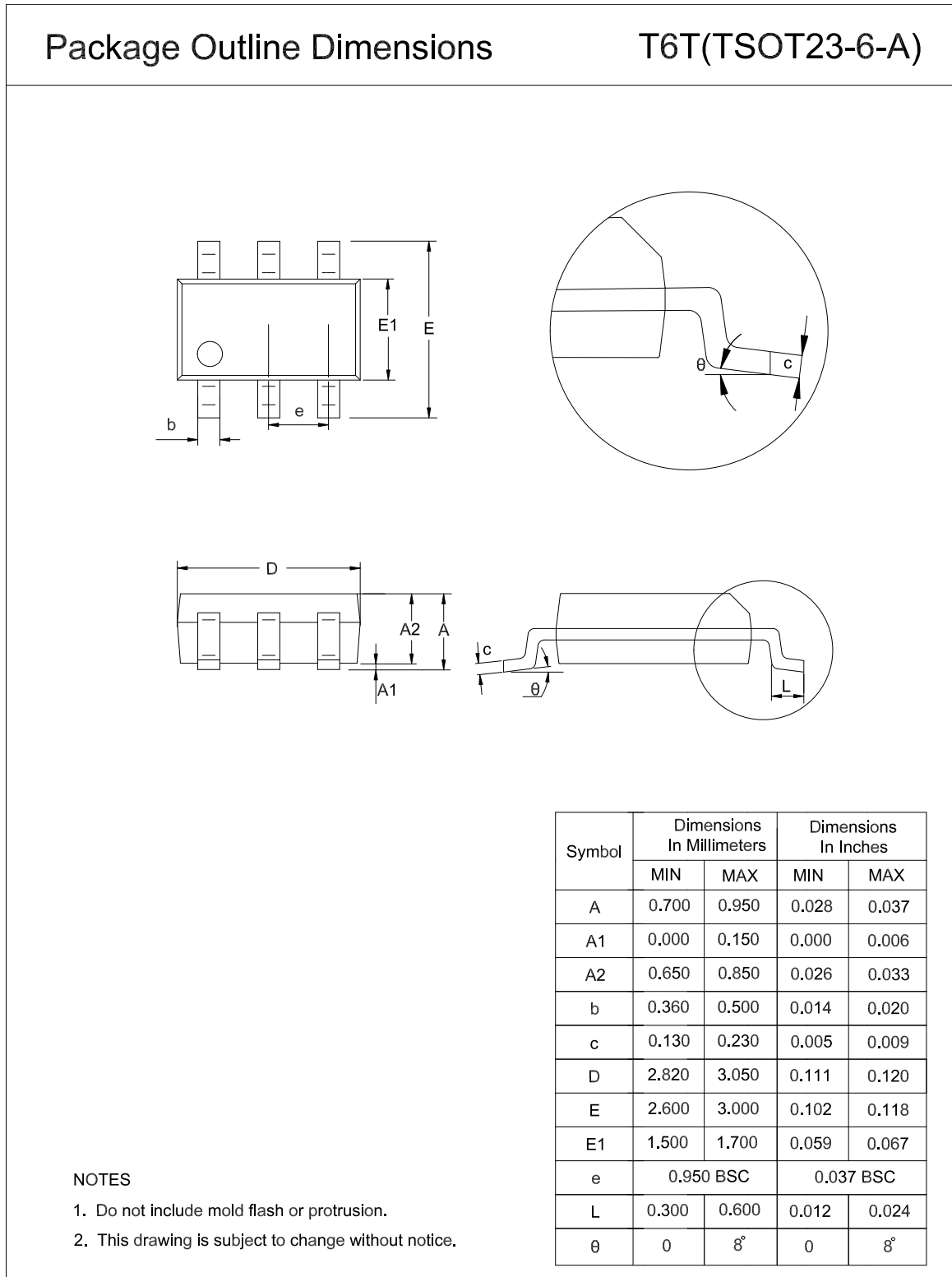
Package Outline Dimensions
TSOT23-6

Order Information

Order Number	Operating Temperature Range	Package	Marking Information	MSL	Transport Media, Quantity	Eco Plan
TPP363080-T6TR	-40 to 125°C	TSOT23-6	330	MSL3	Tape and Reel, 3000	Green
TPP363080-T6TR-S	-40 to 125°C	TSOT23-6	330	MSL3	Tape and Reel, 3000	Green
TPP363081-T6TR	-40 to 125°C	TSOT23-6	331	MSL3	Tape and Reel, 3000	Green
TPP363082-T6TR	-40 to 125°C	TSOT23-6	332	MSL3	Tape and Reel, 3000	Green
TPP363083-T6TR	-40 to 125°C	TSOT23-6	333	MSL3	Tape and Reel, 3000	Green

(1) **Green:** 3PEAK defines "Green" to mean RoHS compatible and free of halogen substances.

IMPORTANT NOTICE AND DISCLAIMER

Copyright© 3PEAK 2012-2024. All rights reserved.

Trademarks. Any of the 思瑞浦 or 3PEAK trade names, trademarks, graphic marks, and domain names contained in this document /material are the property of 3PEAK. You may NOT reproduce, modify, publish, transmit or distribute any Trademark without the prior written consent of 3PEAK.

Performance Information. Performance tests or performance range contained in this document/material are either results of design simulation or actual tests conducted under designated testing environment. Any variation in testing environment or simulation environment, including but not limited to testing method, testing process or testing temperature, may affect actual performance of the product.

Disclaimer. 3PEAK provides technical and reliability data (including data sheets), design resources (including reference designs), application or other design recommendations, networking tools, security information and other resources "As Is". 3PEAK makes no warranty as to the absence of defects, and makes no warranties of any kind, express or implied, including without limitation, implied warranties as to merchantability, fitness for a particular purpose or non-infringement of any third-party's intellectual property rights. Unless otherwise specified in writing, products supplied by 3PEAK are not designed to be used in any life-threatening scenarios, including critical medical applications, automotive safety-critical systems, aviation, aerospace, or any situations where failure could result in bodily harm, loss of life, or significant property damage. 3PEAK disclaims all liability for any such unauthorized use.

This page intentionally left blank