



## IQS227B/D DATASHEET

Single Channel Capacitive Proximity and Touch Controller

The **IQS227B/D** ProxSense® IC is a fully integrated Self Capacitive sensor with dual outputs (Touch and Proximity outputs).

### Features

- > Automatic Tuning Implementation (ATI) - Automatic tuning of sense electrode
- > Minimum external components
- > Data streaming option
- > Advanced on-chip digital signal processing
- > User selectable (OTP) :
  - 4 Power Modes
  - IO sink / source
  - Time-out for stuck key
  - Output mode (Direct/Latch/Toggle)
  - Proximity and Touch Button sensitivity

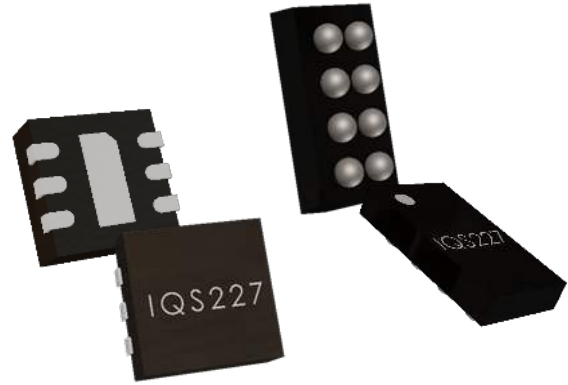

### Applications

- > LCD, Plasma & LED TVs
- > GSM cellular telephones - On ear detection / touch keys
- > LED flashlights or headlamps
- > White goods and appliances
- > Office equipment, toys, sanitary ware
- > Flameproof, hazardous environment Human Interface Devices
- > Proximity detection enables backlighting activation
- > Wake-up from standby applications
- > Replacement for electromechanical switches
- > Find-In-The-Dark (FITD) applications
- > Automotive: Door pocket lighting, electric window control
- > GUI trigger on Proximity detected

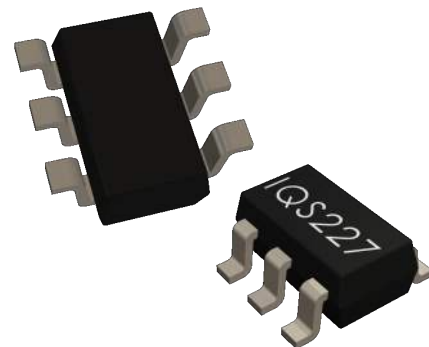

RoHS2  
Compliant

Packages  
Representation only, not actual markings

### Available Options

T <sub>A</sub>	Supply Voltage	Low Power Mode	DFN-6	TSOT23-6	WLCSP-8
-40°C to 85°C	1.8 V to 3.6 V	2.5 µA	IQS227B	IQS227B	IQS227B
	2.4 V to 5.5 V	5 µA	IQS227D	IQS227D	-



## Contents

<b>1 Overview</b>	<b>5</b>
1.1 Device	5
1.2 Operation	5
1.3 Applicability	5
<b>2 Packaging and Pin-Out</b>	<b>6</b>
2.1 Pin-out TSOT23-6	6
2.2 Pin-out WLCSP-8	7
2.3 Pin-out DFN-6	8
<b>3 Schematic</b>	<b>9</b>
3.1 TSOT23-6	9
3.2 WLCSP-8	9
3.3 DFN-6	10
3.4 Additional Information and Recommendations	10
3.5 Recommended Capacitor Values	11
3.6 Exception to recommended capacitor values	11
<b>4 User Configurable Options</b>	<b>12</b>
4.1 Configuring of Devices	12
<b>5 Measuring Capacitance Using the Charge Transfer Method</b>	<b>14</b>
<b>6 Descriptions of User Options</b>	<b>15</b>
6.1 Proximity / Touch Sensor	15
6.2 Logic select for outputs	15
6.3 Output Pin Function	15
6.3.1 Output function: Active	16
6.3.2 Output function: Latch (for $t_{LATCH}$ )	16
6.3.3 Output function: Toggle	16
6.4 Proximity Threshold	17
6.5 Touch Threshold	17
6.6 Power Modes	18
6.7 Base Values	18
6.8 Multipliers	19
6.9 ATI Target Counts	19
6.10 Charge Transfer	19
6.11 Filters used by the IQS227B/D	19
6.11.1 Long Term Average (LTA)	19
6.11.2 IIR Raw Data filter	20
<b>7 Data Streaming Mode</b>	<b>21</b>
7.1 I <sup>2</sup> C	21
<b>8 Automatic Tuning Implementation (ATI)</b>	<b>22</b>
8.1 Automatic ATI	22
<b>9 Electrical Specifications</b>	<b>23</b>
9.1 Absolute Maximum Specifications	23
9.2 IQS227B - General Characteristics	23
9.3 IQS227D - General Characteristics	24



9.4	Output Characteristics . . . . .	24
9.5	Packaging Information . . . . .	25
9.5.1	TSOT23-6 . . . . .	25
9.5.2	WLCSP-8 . . . . .	26
9.5.3	DFN-6 . . . . .	27
9.5.4	MSL Level . . . . .	28
<b>10</b>	<b>Datasheet and Part-number Information</b>	<b>29</b>
10.1	Ordering Information . . . . .	29
10.2	Standard Devices . . . . .	29
10.3	Device Marking - Top . . . . .	30
10.3.1	TSOT23-6 Package Markings . . . . .	30
10.3.2	WLCSP-8 Package Markings . . . . .	31
10.3.3	DFN-6 Package Markings . . . . .	31
10.3.4	Tape and Reel Specification . . . . .	32
<b>11</b>	<b>Known Issues</b>	<b>33</b>
11.1	Undebounced touch without debounced proximity flag set . . . . .	33
<b>A</b>	<b>Memory Map</b>	<b>34</b>



## List of Abbreviations

ATI	Automatic Tuning Implementation
BP	Boost Power Mode
CS	Counts (Number of Charge Transfers)
C <sub>S</sub>	Internal Reference Capacitor
DYCAL™	Dynamic Calibration
EMI	Electromagnetic Interference
ESD	Electro-Static Discharge
FTB/EFT	(Electrical) Fast Transient Bursts
GND	Ground
HC	Halt Charge
LP	Low Power Mode
LTA	Long Term Average
THR	Threshold



## 1 Overview

### 1.1 Device

The IQS227B/D is a single channel capacitive proximity and touch controller with an internal voltage regular and reference capacitor ( $C_S$ ).

The IQS227B/D device has dedicated pin(s) for the connection of sense electrodes ( $C_x$ ) and output pins for proximity events on **POUT** and touch event on **TOUT**. The output pins can be configured for various output methods including a I<sup>2</sup>C data streaming option on **TOUT** and **POUT**.

Device configuration is determined by One Time Programmable (OTP) options. The device can automatically track slow varying environmental changes via various filters and detect noise. It has an Automatic Tuning Implementation (ATI) to tune the device sense electrode(s).

The *charge transfer* method of capacitive sensing is employed on the IQS227B/D. (The Charge Transfer principle is thoroughly described in the application note: [AZD004 - Azoteq Capacitive Sensing](#))

### 1.2 Operation

The analogue circuitry measures the capacitance of a sense electrode attached to the  $C_x$  pin through a charge transfer process that is periodically initiated by the digital circuitry. The measuring process is referred to a conversion and consists of the discharging of reference capacitor and  $C_x$ , the charging of  $C_x$  and then a series of charge transfers from  $C_x$  to  $C_s$  until a trip voltage is reached. The number of charge transfers required to reach the trip voltage is referred to as the Counts (CS). The capacitance measurement circuitry makes use of an internal  $C_s$  and voltage reference (VREG). The analogue circuitry further provides functionality for:

- > Power on reset (POR) detection.
- > Reset detection.
- > Detection of a watch dog timer (WDT)

### 1.3 Applicability

All specifications, except where specifically mentioned otherwise, provided by this datasheet are applicable to the following ranges:

- > Temperature:
  - IQS227B/D: -40°C to 85°C
- > Supply voltage ( $V_{DDHI}$ ):
  - IQS227B: 1.8 V to 3.6 V
  - IQS227D: 2.4 V to 5.5 V



## 2 Packaging and Pin-Out

The IQS227B is available in a TSOT23-6, DFN-6 or WLCSP-8 package. The IQS227D is available in a DFN-6 or TSOT23-6 package.

### 2.1 Pin-out TSOT23-6

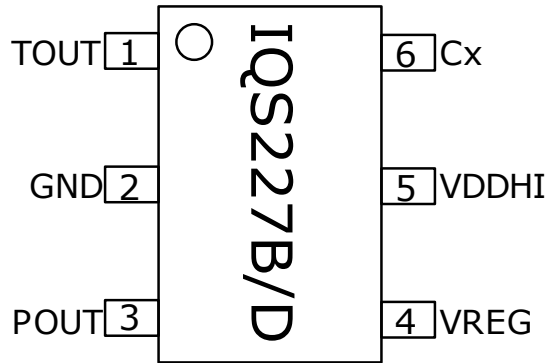

Figure 2.1: IQS227B/D TSOT23-6 Pin-out

Table 2.1: IQS227B/D TSOT23-6 Pin-out Description

Pin	Name	Type	Function
1	TOUT	Digital Output	Touch output
2	GND	Ground	GND Reference
3	POUT	Digital Output	Proximity output
4	VREG	Analogue Output	Internal Regulator Pin (Connect 1 $\mu$ F bypass capacitor)
5	VDDHI	Supply Input	Supply voltage Input
6	Cx	Analogue	Sense Electrode



## 2.2 Pin-out WLCSP-8

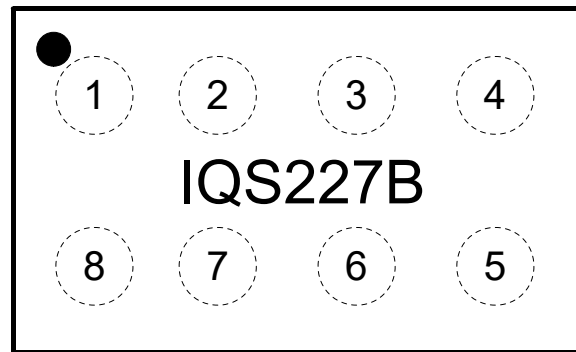
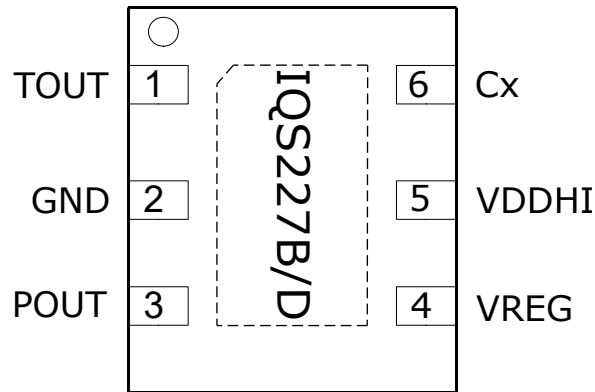

Figure 2.2: IQS227B WLCSP-8 Pin-out

Table 2.2: IQS227B WLCSP-8 Pin-out Description

Pin	Name	Type	Function
1	Cx	Sense electrode	Connect to conductive area intended for sensor
2	TOUT	Digital Output	Touch output
3	VREG	Regulator output	Requires external capacitor
4	VSS	Signal GND	GND Reference
5	INPUT	Digital Input	Floating input during runtime. Recommended: Connect to POUT
6	POUT	Digital Output	Proximity output
7	VDDHI	Supply Input	Supply voltage input
8	PGM	Configuration pin	Connection for OTP programming. Floating input during runtime. Recommended: Connect to TOUT pin. Programming can still be performed using this pin, provided a diode is used. (See <a href="#">AZD026 - Configuration Tools Overview</a> )

### 2.3 Pin-out DFN-6



*Figure 2.3: IQS227B/D DFN-6 Pin-out*

*Table 2.3: IQS227B/D DFN-6 Pin-out Description*

Pin	Name	Type	Function
1	TOUT	Digital Output	Touch Output
2	GND	Ground	GND Reference
3	POUT	Digital Output	Proximity Output
4	VREG	Analogue Output	Internal Regulator Pin
5	VDDHI	Supply Input	Supply voltage Input
6	Cx	Analogue I/O	Sense Electrode
7	PAD	VSS	Electrically connected to GND



### 3 Schematic

#### 3.1 TSOT23-6

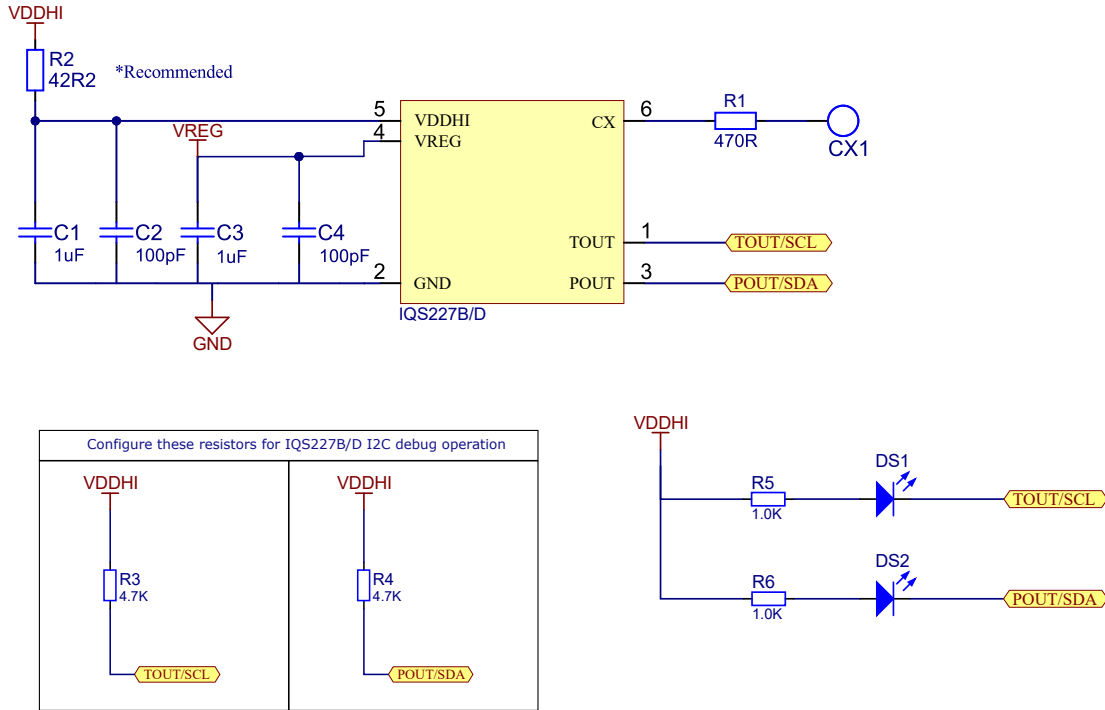

Figure 3.1: Typical application reference schematic of IQS227B/D. 100 pF capacitors are optional for added RF immunity. Place all decoupling capacitors (on VDDHI and VREG) as close to the IC as possible.

#### 3.2 WLCSP-8

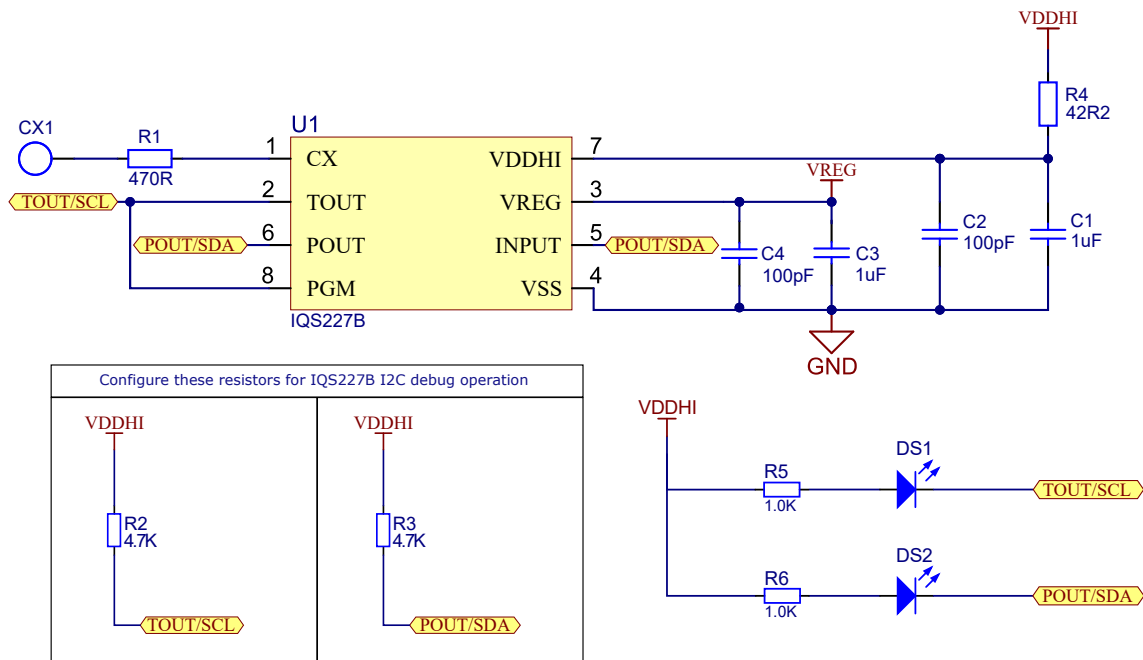

Figure 3.2: Typical application reference schematic of IQS227B WLCSP-8 Package. 100 pF capacitors are optional for added RF immunity. Place all decoupling capacitors (on VDDHI and VREG) as close to the IC as possible.



### 3.3 DFN-6

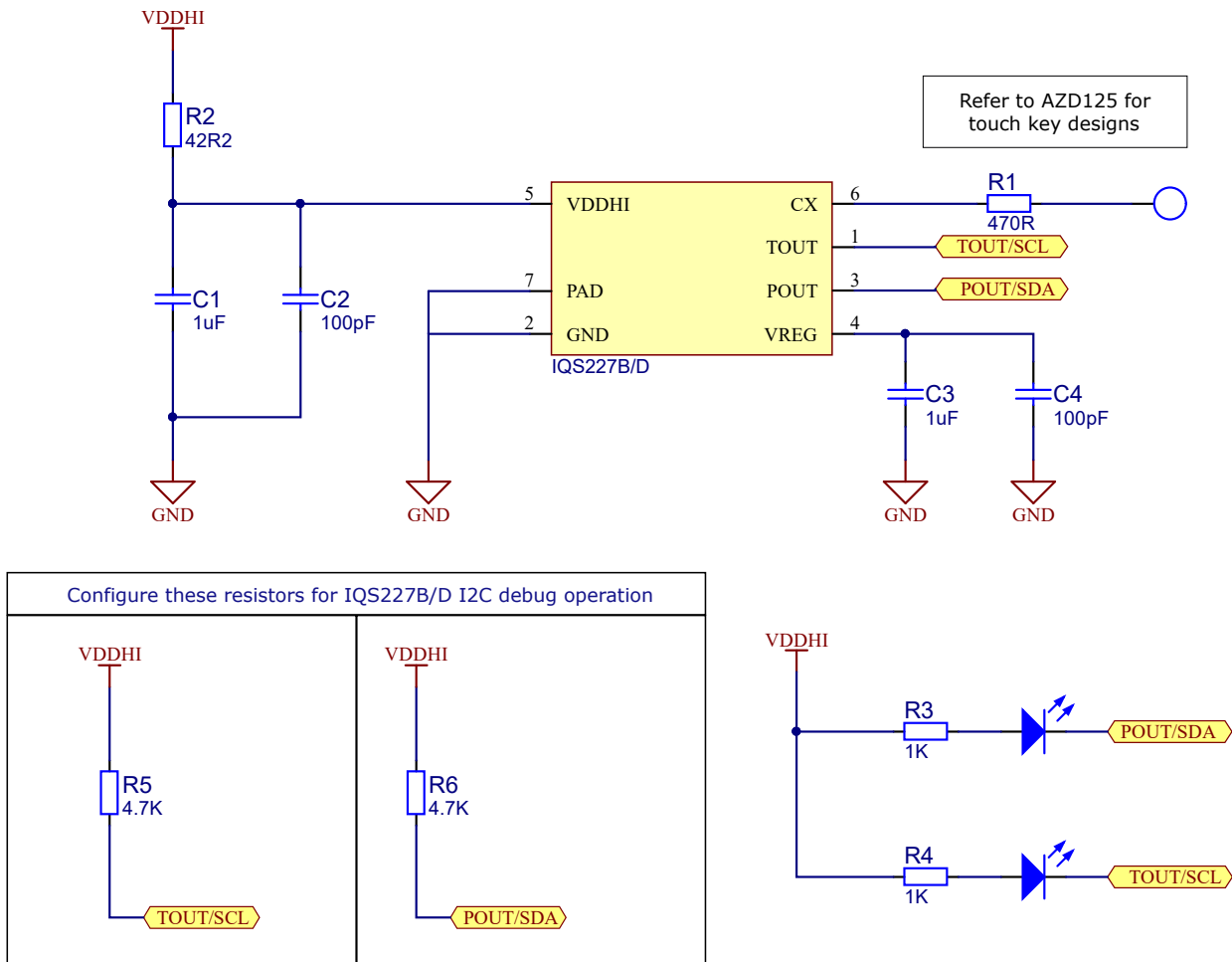

Figure 3.3: Typical application schematic of IQS227B/D. 100 pF capacitors are optional for added RF immunity. Place all decoupling capacitors (on VDDHI and VREG) as close to the IC as possible.

### 3.4 Additional Information and Recommendations

This section describes additional design considerations that is applicable to all reference schematics found in Section 3.1 to 3.3.

Pins TOUT and POUT can be set as Active High or Active Low<sup>i</sup>. See Section 4.1 for more information.

Where a system level ESD strike is found to cause the IC to go into ESD induced latch-up, it is suggested that the supply current to the IQS227B/D IC is limited by means of a series resistor that could limit the maximum supply current to the IC to <80 mA.

The 1 μF capacitors on VDDHI and VREG are for default power mode. Please see Table 3.2 to select the correct capacitors for low power modes.

The 470 Ω series resistor on the Cx pin is added for ESD protection.

<sup>i</sup>With the Active High setting, a pull-up resistor is not required. Adding a pull-up resistor in Active High mode negatively impacts the current usage.



### 3.5 Recommended Capacitor Values

The 1  $\mu\text{F}$  VREG capacitor(C3 in Figure 3.1, 3.2 and 3.3) value is chosen to ensure VREG does not fall the maximum remains above the maximum BOD specification stated in Table 9.2 (IQS227B) and 9.4 (IQS227D). The combination of the 1  $\mu\text{F}$  VREG capacitor and the 1  $\mu\text{F}$  VDDHI capacitor is chosen to prevent a potential ESD issue. Recommended values to prevent this is shown in Table 3.1.

Table 3.1: VDDHI and VREG capacitor size recommendation to prevent ESD issues with typical hardware combinations

Low Power Scan	8ms(default) - 32ms	64ms	128ms	160ms
Capacitor	C1 = 1 $\mu\text{F}$	C1 = 4.7 $\mu\text{F}$	C1 = 4.7 $\mu\text{F}$	C1 = 4.7 $\mu\text{F}$
recommendation	C3 = 1 $\mu\text{F}$	C3 = 2.2 $\mu\text{F}$	C3 = 2.2 $\mu\text{F}$	C3 = 2.2 $\mu\text{F}$

### 3.6 Exception to recommended capacitor values

In applications where the VDDHI source has high internal resistance or a high resistance path, it will be required to ensure  $C3 > C1$  to prevent a VDDHI BOD after the IC sleep cycle (see Table 9.2 and 9.4).

Table 3.2: Capacitor Values for VDDHI and VREG under certain supply voltage condition

Low Power Scan	8ms(default) - 32ms	64ms	128ms	160ms
Capacitor	C1 = 1 $\mu\text{F}$	C1 = 2.2 $\mu\text{F}$	C1 = 4.7 $\mu\text{F}$	C1 = 4.7 $\mu\text{F}$
recommendation	C3 = 1 $\mu\text{F}$	C3 = 4.7 $\mu\text{F}$	C3 = 10 $\mu\text{F}$	C3 = 10 $\mu\text{F}$



## 4 User Configurable Options

The IQS227B/D provides One Time Programmable (OTP) user options (each option can be modified only once). The device is fully functional in the default state. OTP options are intended for specific applications. The configuration of the device can be done on packaged devices or in-circuit. In-circuit configuration may be limited by the values of external components chosen. Several standard device configurations are available. Azoteq can supply pre-configured devices for large quantities.

### 4.1 Configuring of Devices

Azoteq offers a Configuration Tool (CT210) and accompanying software (USBProg2.exe) that can be used to program the OTP user options for prototyping purposes.

Alternative programming solutions for the IQS227B/D also exist. For further enquiries regarding this, please contact Azoteq at [ProxSenseSupport@azoteq.com](mailto:ProxSenseSupport@azoteq.com) or the local distributor.

Tables 4.1 to 4.3 all represent a hexadecimal byte in the IC configuration segment of the ordering number. As example, Table 4.1 corresponds to the last two numeric digits. These digits are shown in bold text in the caption of the table. The ordering numbers and information are explained in Section 10.1.

*Table 4.1: User Selectable Configuration Options: Bank 0 (0xC4H) – IQS227(B/D)0000000DNR*

Bit 7	Bit 6	Bit 5	Bit 4	Bit 3	Bit 2	Bit 1	Bit 0
T <sub>Func</sub>	P <sub>Func</sub>	LOGIC	T <sub>THR2</sub>	T <sub>THR1</sub>	T <sub>THR0</sub>	P <sub>THR1</sub>	P <sub>THR0</sub>

<b>Bit 7</b>	<b>T<sub>Func</sub></b> : Touch Function 0 = Normal 1 = Toggle	Section <a href="#">6.3</a>
<b>Bit 6</b>	<b>P<sub>Func</sub></b> : Proximity Function 0 = Normal 1 = Latch	Section <a href="#">6.3</a>
<b>Bit 5</b>	<b>LOGIC</b> : Output logic select (Only when STREAMING mode is disabled) 0 = Active low (Open drain configuration - pull-up resistor required) 1 = Active High (Push-pull configuration - no pull-up resistor required)	Section <a href="#">6.2</a>
<b>Bit 4-2</b>	<b>T<sub>THR</sub></b> : Touch Threshold Selections <sup>i</sup> 000 = 72/256 001 = 8/256 010 = 24/256 011 = 48/256 100 = 96/256 101 = 128/256 110 = 160/256 111 = 192/256	Section <a href="#">6.5</a>
<b>Bit 1-0</b>	<b>P<sub>THR</sub></b> : Proximity Threshold Selections <sup>i</sup> 00 = 4 01 = 2 10 = 8 11 = 16	Section <a href="#">6.4</a>

<sup>i</sup>Refer to Section [11.1](#) for additional design considerations.



When Full ATI is selected in Bank 2 (Bit 2 in Table 4.3), the settings for bank 1 are those shown in Table 4.2.

Table 4.2: User Selectable Configuration Options: Bank 1 Full ATI (0xC5H) – IQS227(B/D)0000000DNR

Bit 7	Bit 6	Bit 5	Bit 4	Bit 3	Bit 2	Bit 1	Bit 0
t <sub>HALT1</sub>	t <sub>HALT0</sub>	~	~	~	BASE <sub>2</sub>	BASE <sub>1</sub>	BASE <sub>0</sub>

- Bit 7-6** **t<sub>HALT</sub>**: Halt times Section [6.11](#)  
 00 = 20 seconds  
 01 = 40 seconds  
 10 = Never  
 11 = Always (Prox on 40s)
- Bit 5-3** **Reserved**
- Bit 2-0** **BASE**: Base Value Section [6.7](#)  
 000 = 200  
 001 = 50  
 010 = 75  
 011 = 100  
 100 = 150  
 101 = 250  
 110 = 300  
 111 = 500

Table 4.3: User Selectable Configuration Options: Bank 2 (0xC6H) – IQS227(B/D)0000000DNR

Bit 7	Bit 6	Bit 5	Bit 4	Bit 3	Bit 2	Bit 1	Bit 0
STREAM	TRANS	COMMS	~	TARGET	~	LP <sub>1</sub>	LP <sub>0</sub>

- Bit 7** **STREAM**: Streaming Method Section [7.1](#)  
 0 = 1-wire  
 1 = 2-wire (I<sup>2</sup>C)
- Bit 6** **TRANS**: Charge Transfer Frequency Section [6.10](#)  
 0 = 512 kHz  
 1 = 250 kHz
- Bit 5** **COMMS**: Streaming Section [7](#)  
 0 = Disabled  
 1 = Enabled
- Bit 4** **Reserved** - Set 0
- Bit 3** **TARGET**: ATI Target Counts Section [6.9](#)  
 0 = 1024  
 1 = 512
- Bit 2** **ATI**: ATI Selection Section [8](#)  
 0 = Full  
 1 = Partial (Not recommended - Contact Azoteq®)
- Bit 1-0** **LP**: Low Power Modes Section [6.6](#)  
 00 = BP, 9 ms  
 01 = NP, 128 ms  
 10 = LP1, 256 ms  
 11 = LP2, 512 ms (Not recommended, refer to Table [3.1](#) and [3.2](#))



## 5 Measuring Capacitance Using the *Charge Transfer Method*

The charge transfer method of capacitive sensing is employed on the IQS227B/D. (The charge transfer principle is thoroughly described in the application note: [AZD004 - Azoteq Capacitive Sensing](#)).

A charge cycle is used to take a measurement of the capacitance of the sense electrode (connected to Cx) relative to ground. It consists of a series of pulses charging Cx and discharging Cx to the reference capacitor, at the charge transfer frequency ( $f_{Cx}$  - refer to Section 9.2 and 9.3). The number of the pulses required to reach a trip voltage on the reference capacitor is referred to as Count Value (CS) which is the instantaneous capacitive measurement. The Counts (CS) are used to determine if either a physical contact or proximity event occurred (refer to Section 6.11.1), based on the change in Counts (CS) detected. The typical values of CS, without a touch or proximity condition range between 650 and 1150 Counts, although higher and lower counts can be used based on the application requirements. With counts larger than +/-1150 the gain of the system may become too high causing unsteady operation.

The IQS227B/D schedules a charge cycle every  $t_{SAMPLE}$  seconds to ensure regular samples for the processing of results. The duration of the charge cycle is defined as  $t_{CHARGE}$  (refer to Section 6.6), and varies according to the counts required to reach the trip voltage. Following the charge cycle other activities such as data streaming is completed (if in streaming mode), before the next charge cycle is initiated.

**Please note: Attaching a probe to the Cx pin will increase the capacitance of the sense plate and therefore Cs. This may have an immediate influence on the counts (decrease  $t_{CHARGE}$ ) and cause a proximity or touch event.**

After  $t_{HALT}$  seconds the system will adjust to accommodate for this change. If the total load on Cx, with the probe attached is still lower than the maximum Cx load the system will continue to function normally after  $t_{HALT}$  seconds with the probe attached.

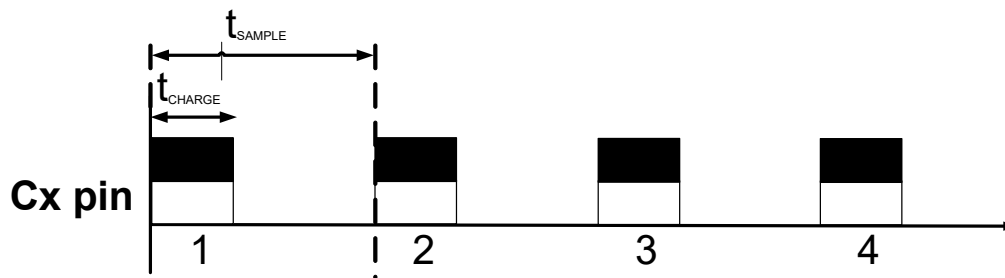

Figure 5.1: Charge cycles as can be seen on Cx.



## 6 Descriptions of User Options

This section describes the individual user programmable options of the IQS227B/D in more detail.

User programmable options are programmed to One Time Programmable (OTP) fuse registers (refer to Section 4).

**Note:**

- > HIGH=Logical '1' and LOW=Logical '0'.
- > The following sections are explained with POUT and TOUT taken as 'Active LOW'.
- > The default is always where bits are set to 0.

Refer to Section 9.4 for the sourcing and sinking capabilities POUT and TOUT. These pins are sourced from VDDHI and will be turned HIGH (when active high) for a minimum time of  $t_{HIGH}$ , and LOW for a minimum time of  $t_{LOW}$  (when active low).

### 6.1 Proximity / Touch Sensor

The IQS227B/D provides a Proximity output on POUT and a Touch output on TOUT, and does not need to be configured.

### 6.2 Logic select for outputs

The logic used by the device can be selected as active HIGH or active LOW. The output pins, POUT and TOUT, will function based on this selection. The I/O's are push-pull in both directions and does not require a pull-up resistor. When configured as Active High, the I/O's will remain high at POR until ATI has been completed. ATI times will vary based on the capacitive load on the sensor, but typically do not exceed 500 ms.

Configuration: [Bank 0 Bit 5](#)

LOGIC: Output Logic Select	
Bit	Selection
0	Active Low
1	Active High

### 6.3 Output Pin Function

Various options for the function of the output pin(s) are available. These are selected as follows:

Configuration: [Bank 0 Bit 7-6](#)

FUNC1:FUNC0 OUTPUT Pins' functions	
Bit	Selection
00	POUT active, TOUT active
01	POUT latch, TOUT active
10	POUT active, TOUT toggle
11	POUT latch, TOUT toggle



### 6.3.1 Output function: Active

With a Proximity or Touch event, the output pin will change to LOW and stay LOW for as long as the event remains (see Figure 6.1). Also refer to the use of  $t_{\text{HALT}}$  Section 6.11.1 that may cause the termination of the event.

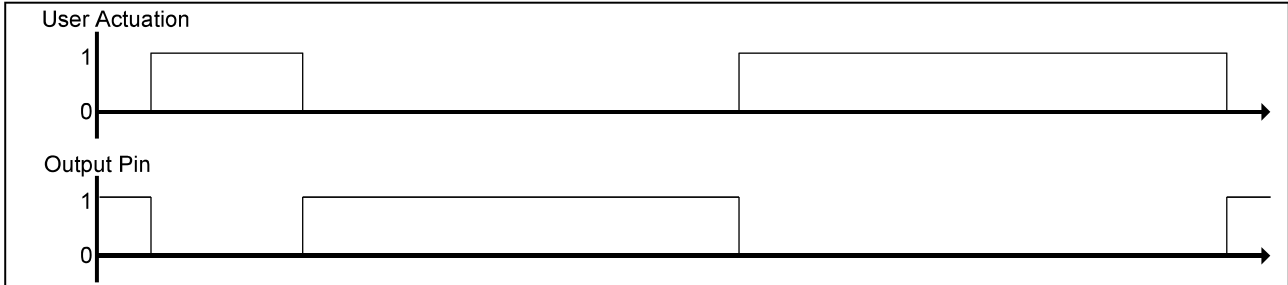

Figure 6.1: Active Mode Output Configuration

### 6.3.2 Output function: Latch (for $t_{\text{LATCH}}$ )

With a Proximity or Touch event, the output pin will latch LOW for  $t_{\text{LATCH}}$  seconds (4 seconds). When the event terminates prior to  $t_{\text{LATCH}}$  the output pin will remain LOW. When the event remains active longer than  $t_{\text{LATCH}}$  the output pin will remain LOW as long as the event remains active (see Figure 6.2). When a subsequent event is made before the latch time (4 seconds) has passed, the timer will reset and the output will remain low for another duration of  $t_{\text{LATCH}}$  seconds (4 seconds). For more details see Figure 6.2.

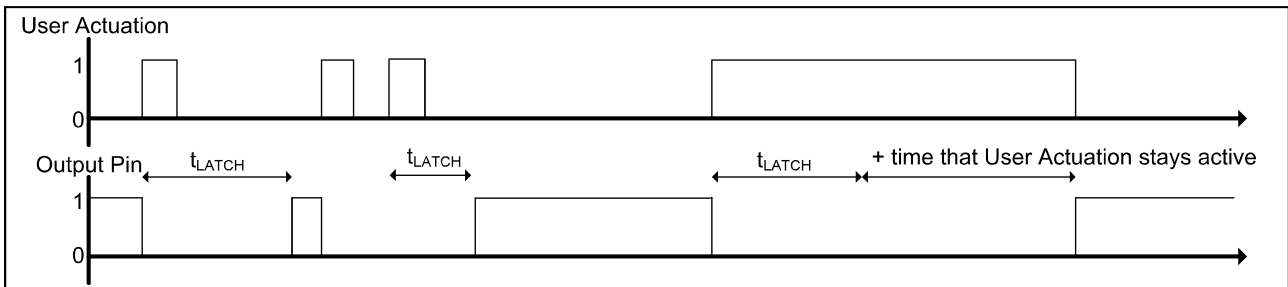

Figure 6.2: Latch Mode Output Configuration

### 6.3.3 Output function: Toggle

The output pin will toggle with every Proximity or Touch event occurring. Thus, when an event occurs and the output is LOW the output will become HIGH and when the output is HIGH the output will become LOW (see Figure 6.3)

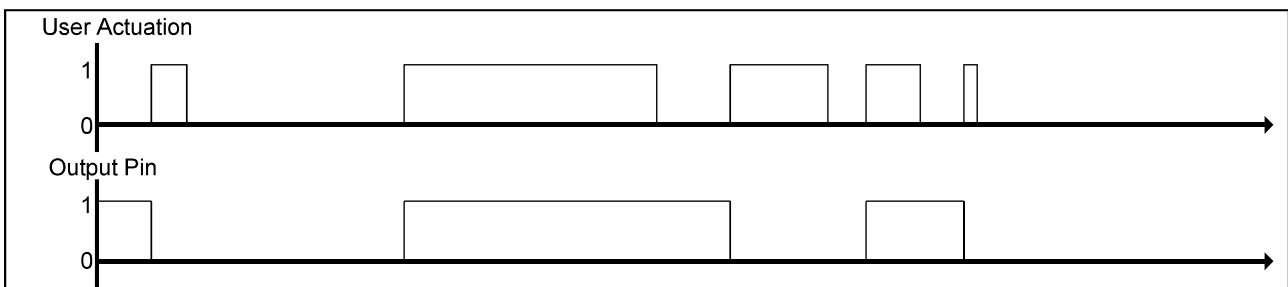

Figure 6.3: Toggle Mode Output Configuration



## 6.4 Proximity Threshold

The IQS227B/D has 4 proximity threshold settings<sup>i</sup>. The proximity threshold is selected by the designer to obtain the desired sensitivity and noise immunity. The proximity event is triggered based on the selected proximity threshold; the Counts (CS) and the LTA (Long Term Average). The threshold is expressed in terms of counts; the same as CS (refer to Section 5). A proximity event is identified when for at least 6 consecutive samples the following equation holds:

$$P_{THR} = < LTA - CS \tag{1}$$

Where LTA is the Long Term Average (refer to Section 6.11.1)

Configuration: *Bank 0 Bit 1-0*

P <sub>THR1</sub> :P <sub>THR0</sub> Proximity Threshold	
Bit	Selection
00	4
01	2 (Most sensitive)
10	8
11	16 (Least sensitive)

## 6.5 Touch Threshold

The IQS227B/D has 8 touch threshold settings<sup>i</sup>. The touch threshold is selected by the designer to obtain the desired touch sensitivity. The touch threshold is expressed as a fraction of the LTA as follows:

$$T_{THR} = \frac{x}{256} * LTA \tag{2}$$

The touch event is triggered based on T<sub>TH</sub>, Counts (CS) and LTA. A touch event is identified when for at least 3 consecutive samples the following equation holds:

$$T_{THR} = < LTA - CS \tag{3}$$

With lower average counts (therefore lower LTA) values the touch threshold will be lower and vice versa.

<sup>i</sup>Refer to Section 11.1 for additional design considerations.



Configuration: *Bank 0 Bit 4-2*

T <sub>THR2</sub> :T <sub>THR0</sub> : Touch Thresholds		
Bit	Selection	
000	72/256	
001	8/256	(Most sensitive)
010	24/256	
011	48/256	
100	96/256	
101	128/256	
110	160/256	
111	192/256	(Least sensitive)

### 6.6 Power Modes

The IQS227B/D has four power modes specifically designed to reduce current consumption for battery applications. The power modes are basically implemented around the occurrence of charge cycle every  $t_{SAMPLE}$  seconds (refer to Table 4.3). The fewer charge transfer cycles that need to occur per second the lower the power consumption (but decreased response time). During Boost Power Mode (BP), charge cycles are initiated approximately every 9 ms. While in any power mode the device will zoom to BP whenever an existing count sample (CS) indicates a possible proximity or touch event. The device will remain in BP for  $t_{ZOOM}$  seconds and then return to the selected power mode. The Zoom function allows reliable detection of events with counts being produced at the BP rate.

Configuration: *Bank 2 Bit 1-0*

LP : Power Mode Selection	
Bit	Selection
00	9 ms (Boost Power Mode)
01	128 ms (Normal Power Mode)
10	256 ms (Low Power Mode 1)
11	512 ms (Low Power Mode 2) Not recommended, refer to Table 3.1 and 3.2

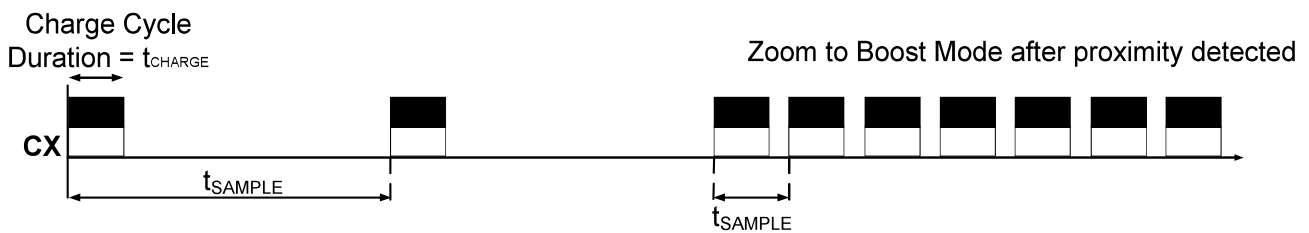

Figure 6.4: Active Mode Output Configuration

### 6.7 Base Values

The sensitivity of the IQS227B/D can be changed by adjusting the target and base values of the ATI algorithm, and as a result changing the compensation required to reach the set target. See Section 4.1 for the OTP selectable options of BASE (Table 4.2).

$$sensitivity = \frac{TARGET}{BASE} \tag{4}$$



Configuration: [Bank 1 Bit 2-0](#)

**BASE** : Base Value Select

Bit	Selection
000	200
001	50 (Not Recommended - Contact Azoteq®)
010	75
011	100
100	150
101	250
110	300
111	500

## 6.8 Multipliers

When using partial ATI, the base value is set up using the multipliers. Compensation will still be added automatically to reach the target.

## 6.9 ATI Target Counts

The target of the ATI algorithm can be adjusted between 1024 (default) and 512 counts. When less sensitivity is required, the lower counts will also increase response rate. See Section [4.1](#) for the OTP selectable options of TARGET (Table [4.3](#)).

Configuration: [Bank 2 Bit 3](#)

**TARGET** : ATI Target Counts

Bit	Selection
0	1024
1	512

## 6.10 Charge Transfer

The charge transfer frequency of the IQS227B/D is adjustable. Refer to application note [AZD102 - Series resistance limit of self capacitance charge transfers](#). Two options are available:

Configuration: [Bank 2 Bit 6](#)

**TRANS** : Charge Transfer Frequency

Bit	Selection
0	512 kHz
1	250 kHz

## 6.11 Filters used by the IQS227B/D

The IQS227B/D devices employ various signal processing functions that includes the execution of various filters as described below.

### 6.11.1 Long Term Average (LTA)

Capacitive touch devices detect changes in capacitance that are not always related to the intended proximity or touch of a human. This is a result of changes in the environment of the sense plate



and other factors. These changes need to be compensated for in various manners in order to reliably detect touch events and especially to detect proximity events. One mechanism the IQS227B/D employs is the use of a Long Term Averaging filter (IIR type filter) which tracks slow changes in the environment (expressed as changes in the counts). The result of this filter is a Long Term Average (LTA) value that forms a dynamic reference used for various functions such as identification of proximity and touch events.

The LTA is calculated from the counts (CS). The filter only executes while no proximity or touch event is detected to ensure compensation only for environmental changes. However, there may be instances where sudden changes in the environment or changes in the environment while a proximity or touch event has been detected cause the counts to drift away from the LTA. To compensate for these situations a Halt Timer ( $t_{\text{HALT}}$ ) has been defined. The Halt Timer is started when a proximity or touch event occurs and when it expires the LTA filter is recalibrated. Recalibration causes  $LTA < CS$ , thus the disappearance of proximity or touch events (refer to Sections 6.4 and 6.5). The designer needs to select a Halt Timer value to best accommodate the required application.

**Configuration:** [Bank 1 Bit 7-6](#)

$t_{\text{HALT1}}:t_{\text{HALT0}}$ OUTPUT Pins' functions	
Bit	Selection
00	20 seconds
01	40 seconds
10	NEVER
11	ALWAYS (Proximity on 40 seconds)

**Notes:**

- > The “NEVER” option indicates that the execution of the filters will never be halted.
- > With the ‘ALWAYS’ option and the detection of a proximity event the execution of the filter will be halted for only 40 seconds and with the detection of a touch event the execution of the filter will be halted as long as the touch condition applies.

Refer to Application note [AZD004 - Azoteq Capacitive Sensing](#) for detail regarding the execution of the LTA filter.

**6.11.2 IIR Raw Data filter**

The extreme sensitivity of the IQS227B/D makes it susceptible to external noise sources. This causes a decreased signal-to-noise (S/N) ratio, which could potentially cause false event detections. Noise can also couple into the device as a result of poor PCB, sense electrode design and other factors influencing capacitive sensing devices. In order to compensate for noise the IQS227B/D uses an IIR filter on the raw data to minimize result of noise in the counts. This filter is implemented on all the IQS227B/D devices, and cannot be disabled.



## 7 Data Streaming Mode

The IQS227B/D has the capability to stream data to an MCU. This provides the designer with the capability to obtain the parameters within the device in order to aid design into applications. Data streaming may further be used by an MCU to control events or further process results obtained from the IQS227B/D devices. Data streaming is performed through I<sup>2</sup>C communication (SDA on POUT, SCL on TOUT). Data Streaming can be enabled as indicated below:

Configuration: [Bank 2 Bit 7](#)

### COMMS: Data Streaming

Bit	Selection
-----	-----------

0	Disabled
---	----------

1	Enabled
---	---------

Configuration: [Bank 2 Bit 5](#)

### STREAMING: Data Streaming Mode

Bit	Selection
-----	-----------

0	1-wire
---	--------

1	2-wire (I <sup>2</sup> C)
---	---------------------------

Data streaming is initiated by the IQS227B/D. When data streaming is enabled, data is sent following each charge.

### 7.1 I<sup>2</sup>C

The IQS227B/D also allow for I<sup>2</sup>C streaming for debugging. Data Streaming can be changed to I<sup>2</sup>C as shown below:

Configuration: [Bank 2 Bit 7](#)

### STREAMING: Data Streaming Mode

Bit	Selection
-----	-----------

0	1-wire
---	--------

1	2-wire (I <sup>2</sup> C)
---	---------------------------

The Memory Map for the IQS227B/D can be found in Appendix A. The IQS227B/D can communicate on an I<sup>2</sup>C compatible bus structure. Note that 4.7 kΩ pull-up resistors should be placed on SDA and SCL. The Control byte indicates the 7-bit device address (0x44H) and the Read/Write indicator bit.



## 8 Automatic Tuning Implementation (ATI)

ATI is sophisticated technology implemented in the latest generation ProxSense® devices that optimises the performance of the sensor in a wide range of applications and environmental conditions (refer to application note [AZD004](#)).

ATI makes adjustments through external reference capacitors unnecessary (as required by most other solutions) to obtain optimum performance.

ATI adjusts internal circuitry according to two parameters, the ATI multiplier and the ATI compensation. The ATI multiplier can be viewed as a course adjustment and the ATI compensation as a fine adjustment. The adjustment of the ATI parameters will result in variations in the counts and sensitivity. Sensitivity can be observed as the change in current sample as the result of a fixed change in sensed capacitance. The ATI parameters have been chosen to provide significant overlap. It may therefore be possible to select various combinations of ATI multiplier and ATI compensation settings to obtain the same count value. The sensitivity of the various options may however be different for the same count value.

### 8.1 Automatic ATI

The IQS227B/D implements an automatic ATI algorithm. This algorithm automatically adjusts the ATI parameters to optimise the sensing electrodes connection to the device. The device will execute the ATI algorithm whenever the device starts-up and when the counts are not within a predetermined range. While the Automatic ATI algorithm is in progress this condition will be indicated in the streaming data and proximity and touch events cannot be detected. The device will only briefly remain in this condition, and it will be entered only when relatively large shifts in the counts has been detected. The automatic ATI function aims to maintain a constant count value, regardless of the capacitance of the sense electrode (within the maximum range of the device). The effects of auto-ATI on the application are the following:

- > Automatic adjustment of the device configuration and processing parameters for a wide range of PCB and application designs to maintain an optimal configuration for proximity and touch detection.
- > Automatic tuning of the sense electrode at start-up to optimise the sensitivity of the application.
- > Automatic re-tuning when the device detects changes in the sensing electrodes capacitance to accommodate a large range of changes in the environment of the application that influences the sensing electrode.
- > Re-tuning only occurs during device operation when a relatively large sensitivity reduction is detected. This is to ensure smooth operation of the device during operation.
- > Re-tuning may temporarily influence the normal functioning of the device, but in most instances the effect will be hardly noticeable.
- > Shortly after the completion of the re-tuning process the sensitivity of a Proximity detection may be reduced slightly for a few seconds as internal filters stabilises.

Automatic ATI can be implemented so effectively due to:

- > Excellent system signal-to-noise ratio (SNR).
- > Effective digital signal processing to remove AC and other noise.
- > The very stable core of the devices.
- > Built in capability to accommodate a large range of sensing electrode capacitances.



## 9 Electrical Specifications

### 9.1 Absolute Maximum Specifications

**Exceeding these maximum specifications may cause damage to the device**

Operating temperature		-40°C to 85°C
Supply Voltage ( $V_{DDHI}-V_{SS}$ ):	IQS227B	3.6V
	IQS227D	5.5V
Maximum pin Voltage ( $T_{OUT}, P_{OUT}$ )		$V_{DDHI} + 0.3V$
Minimum pin voltage ( $V_{DDHI}, V_{REG}, T_{OUT}, P_{OUT}, C_X$ )		$V_{SS} - 0.3V$
Minimum power-on slope		100V/s
ESD protection ( $V_{DDHI}, V_{REG}, V_{SS}, T_{OUT}, P_{OUT}, C_X$ )		8kV

### 9.2 IQS227B - General Characteristics

IQS227B devices are rated for supply voltages between 1.8 V and 3.6 V.

*Table 9.1: IQS227B General Operating Conditions*

Description	Conditions	Parameter	Min	Typ	Max	Unit
Supply voltage		$V_{DDHI}$	1.8	~	3.6	V
Internal regulator output	$1.8 \leq V_{DDHI} \leq 3.6$	$V_{REG}$	1.64	~	1.75	V
Boost operating current	$1.8 \leq V_{DDHI} \leq 3.6$	$I_{IQS227B\_BP}$	~	128	~	$\mu A$
Normal operating current	$1.8 \leq V_{DDHI} \leq 3.6$	$I_{IQS227B\_NP}$	~	6	~	$\mu A$
Low Power 1 operating current	$1.8 \leq V_{DDHI} \leq 3.6$	$I_{IQS227B\_LP1}$	~	3.5	~	$\mu A$
Low Power 2 operating current	$1.8 \leq V_{DDHI} \leq 3.6$	$I_{IQS227B\_LP2}$	~	<2.5	~	$\mu A$
$C_X$ pin capacitance	$1.8 \leq V_{DDHI} \leq 3.6$	$C_{X\_Load}$	~	~	120	pF
Charge transfer frequency range	$1.8 \leq V_{DDHI} \leq 3.6$	$f_{C_X} = 512/250$	-8%	$f_{C_X}$	+8%	kHz

Charge Transfer Timings for low power modes are found in section 6.6.

*Table 9.2: IQS227B Start-up and shut-down slope Characteristics*

Description	Parameter	Min	Max	Unit
Reset release voltage on $V_{DDHI}$ rising edge	$V_{DDHI}$ Reset Rising Edge (POR)	~	1.7	V
Reset trigger voltage on $V_{DDHI}$ falling edge	$V_{DDHI}$ Reset Falling Edge (BOD)	0.3	~	V
Reset release voltage on $V_{REG}$ rising edge	$V_{REG}$ Reset Rising Edge (POR)	~	1.58	V
Reset trigger voltage on $V_{REG}$ falling edge	$V_{REG}$ Reset Falling Edge (BOD)	0.3	~	V



### 9.3 IQS227D - General Characteristics

IQS227D devices are rated for supply voltages between 2.4 V and 5.5 V.

Table 9.3: IQS227D General Operating Conditions

Description	Conditions	Parameter	Min	Typ	Max	Unit
Supply voltage		V <sub>DDHI</sub>	2.4	~	5.5	V
Internal regulator output	2.4 ≤ V <sub>DDHI</sub> ≤ 5.5	V <sub>REG</sub>	1.98	~	2.08	V
Boost operating current	2.4 ≤ V <sub>DDHI</sub> ≤ 5.5	I <sub>IQS227D_BP</sub>	~	101	~	μA
Normal operating current	2.4 ≤ V <sub>DDHI</sub> ≤ 5.5	I <sub>IQS227D_NP</sub>	~	6	~	μA
Low Power 1 operating current	2.4 ≤ V <sub>DDHI</sub> ≤ 5.5	I <sub>IQS227D_LP1</sub>	~	4.5	~	μA
Low Power 2 operating current	2.4 ≤ V <sub>DDHI</sub> ≤ 5.5	I <sub>IQS227D_LP2</sub>	~	<3.2	~	μA
C <sub>x</sub> pin capacitance	2.4 ≤ V <sub>DDHI</sub> ≤ 5.5	C <sub>X_Load</sub>	~	~	120	pF
Charge transfer frequency range	2.4 ≤ V <sub>DDHI</sub> ≤ 5.5	f <sub>Cx</sub> = 512/250	-8%	f <sub>Cx</sub>	+8%	kHz

Charge Transfer Timings for low power modes are found in section 6.6.

Table 9.4: Start-up and shut-down slope Characteristics

Description	Parameter	Min	Max	Unit
Reset release voltage on V <sub>DDHI</sub> rising edge	V <sub>DDHI</sub> Reset Rising Edge (POR)	~	2.1	V
Reset trigger voltage on V <sub>DDHI</sub> falling edge	V <sub>DDHI</sub> Reset Falling Edge (BOD)	0.3	~	V
Reset release voltage on V <sub>REG</sub> rising edge	V <sub>REG</sub> Reset Rising Edge (POR)	~	1.8	V
Reset trigger voltage on V <sub>REG</sub> falling edge	V <sub>REG</sub> Reset Falling Edge (BOD)	0.3	~	V

### 9.4 IQS227B/D Output Characteristics

Table 9.5: Digital I/O Characteristics

Parameter	Test Conditions	Min	Typ	Max	Unit
V <sub>OL</sub>	TOUT and POUT Output low voltage I <sub>sink</sub> = 10 mA	~	~	0.3	V
V <sub>OH</sub>	Output high voltage I <sub>source</sub> = 5 mA	VDD – 0.3	~	~	V
V <sub>IL</sub>	Input low voltage	~	~	0.3 × VDD	V
V <sub>IH</sub>	Input high voltage	0.7 × VDD	~	~	V



## 9.5 Packaging Information

### 9.5.1 TSOT23-6

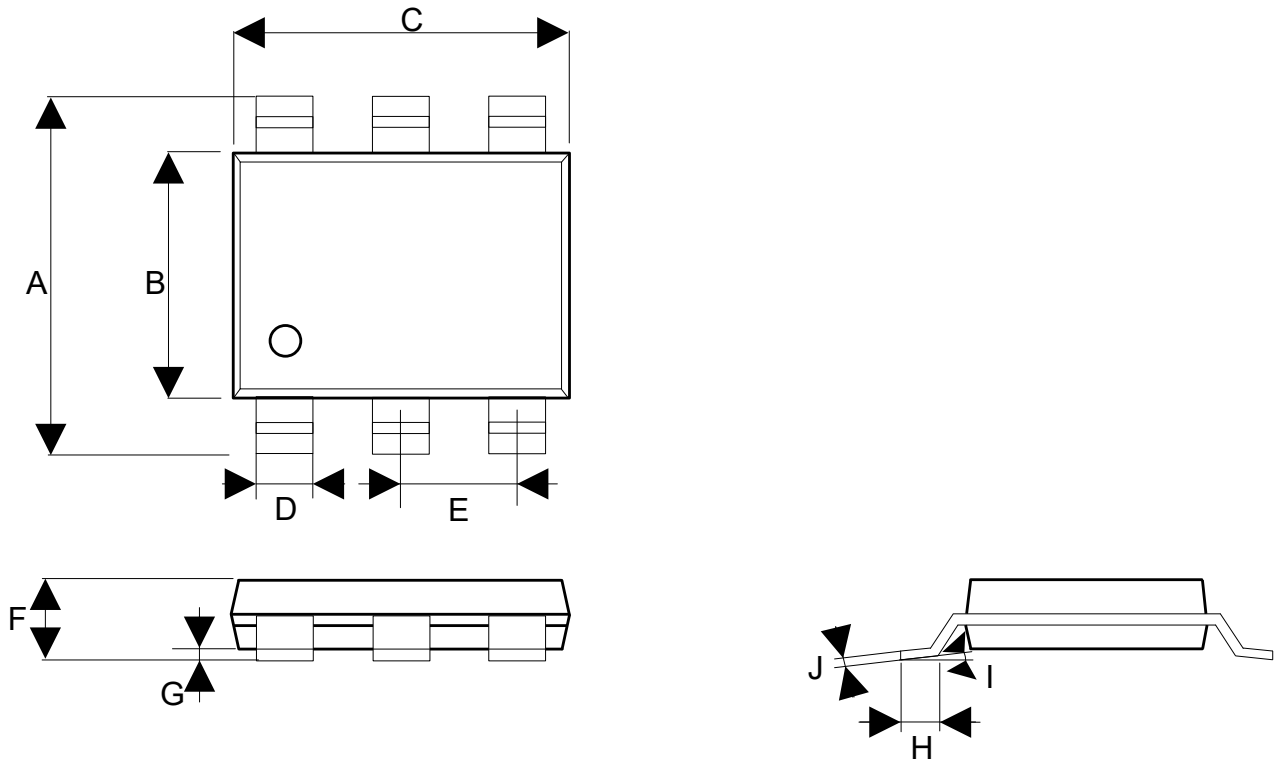

Figure 9.1: IQS227B/D TSOT23-6 Packaging

Table 9.6: IQS227B/D TSOT23-6 Dimensions

Dimension	Min (mm)	Max (mm)
A	2.60	3.00
B	1.50	1.70
C	2.80	3.00
D	0.30	0.50
E	0.95 Basic	
F	0.84	1.00
G	0.00	0.10
H	0.30	0.50
I	0°	8°
J	0.03	0.20



### 9.5.2 WLCSP-8

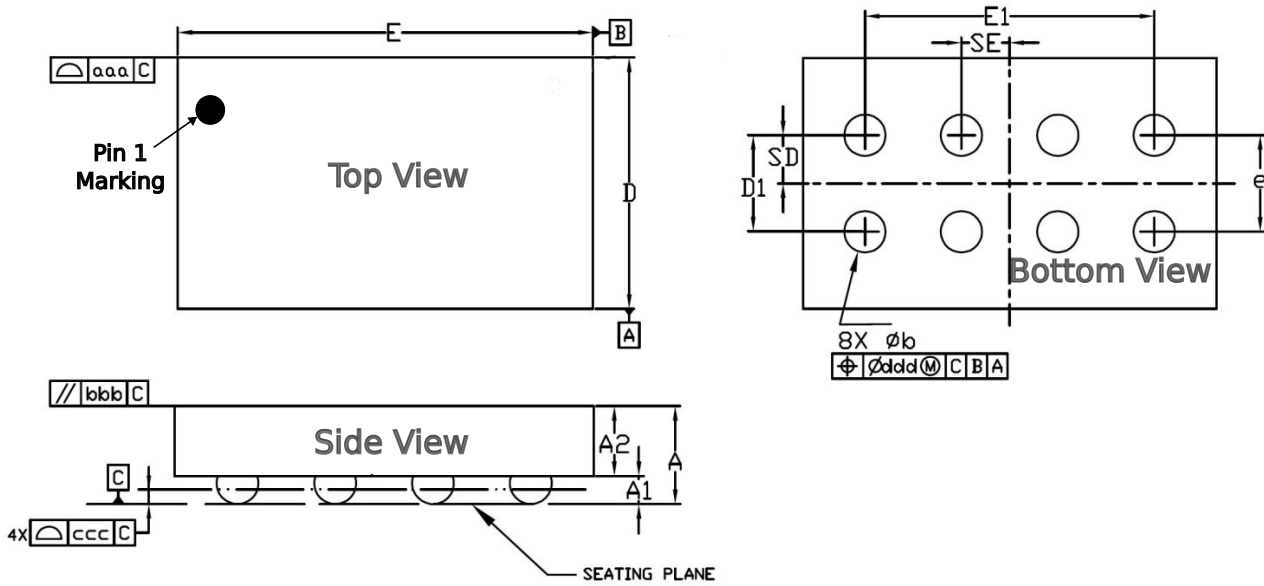

Figure 9.2: IQS227B WLCSP-8 Dimensions (in mm)

Table 9.7: IQS227B WLCSP-8 Dimensions

Dimensional Ref			
REF.	Min (mm)	Nom (mm)	Max (mm)
A	0.310	0.350	0.390
A1	0.085	0.100	0.115
A2	0.225	0.250	0.275
D	0.865	0.880	0.895
E	1.455	1.470	1.485
D1	0.300	0.350	0.400
E1	1.000	1.050	1.100
b	0.125	0.150	0.175
e		0.350 BSC	
SD		0.175 BSC	
SE		0.175 BSC	
Tol. Form & Position			
aaa		0.10	
bbb		0.10	
ccc		0.05	
ddd		0.05	



### 9.5.3 DFN-6

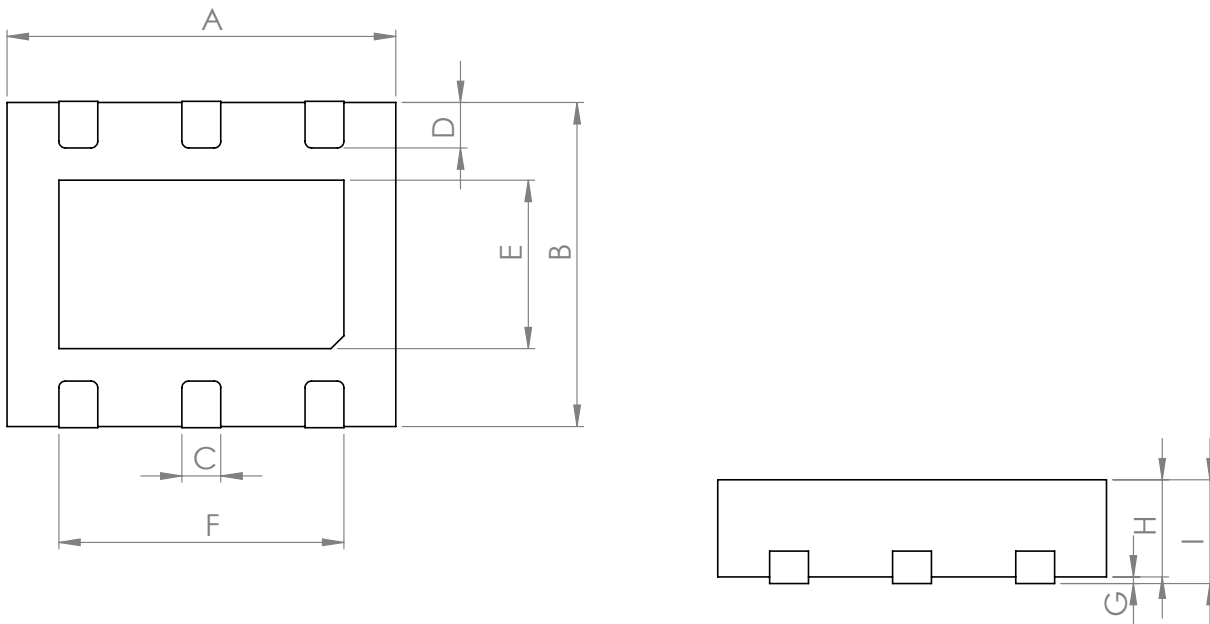

Figure 9.3: IQS227B/D DFN-6 Packaging

Table 9.8: IQS227B/D DFN-6 Dimensions

Dimension	Min (mm)	Max (mm)
A	3.00	3.00
B	2.50	2.50
C	0.30	0.30
D	0.35	0.35
E	1.30	1.30
F	2.20	2.20
G	0.05	0.05
H	0.75	0.75
I	0.80	0.80



#### 9.5.4 MSL Level

**Moisture Sensitivity Level (MSL)** relates to the packaging and handling precautions for some semi-conductors. The MSL is an electronic standard for the time period in which a moisture sensitive device can be exposed to ambient room conditions (approximately 30°C/85% RH see J-STD003C for more information) before reflow occurs.

Package	Level (duration)
TSOT23-6	MSL 1 (Unlimited at $\leq 30^{\circ}\text{C}/85\% \text{RH}$ ) Reflow profile peak temperature $< 260^{\circ}\text{C}$ for $< 30$ seconds
WLCSP-8	Non-encapsulated device - not moisture sensitive Reflow profile peak temperature $< 260^{\circ}\text{C}$ for $< 30$ seconds
DFN-6	MSL 1 (Unlimited at $\leq 30^{\circ}\text{C}/85\% \text{RH}$ ) Reflow profile peak temperature $< 260^{\circ}\text{C}$ for $< 30$ seconds



## 10 Datasheet and Part-number Information

### 10.1 Ordering Information

Contact the official distributor for sample quantities. A list of the distributors can be found under the "Distributors" section of [www.azoteq.com](http://www.azoteq.com). Special MOQs apply for custom configurations.

The Part-number can be generated by using USBProg2.exe.

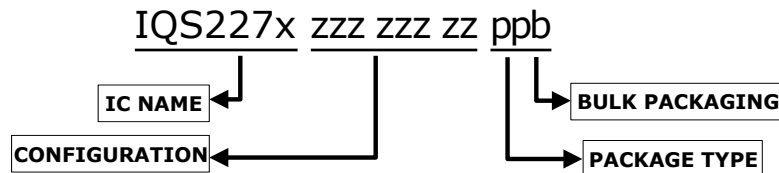

<b>IC NAME</b>	IQS227B	=	Self Capacitive IC with Dual Outputs (3.3V)
	IQS227D	=	Self Capacitive IC with Dual Outputs (5V)
<b>CONFIGURATION</b>	zzz zzz zz	=	IC Configuration (hexadecimal - See Section <a href="#">4.1</a> )
<b>PACKAGE TYPE</b>	TS	=	TSOT23-6 package
	CS	=	WLCSP-6 package
	DN	=	DFN-6 package
<b>BULK Packaging</b>	R	=	Reel
		=	TSOT23-6 (3000pcs/reel)
		=	WLCSP-6 (3000pcs/reel)
		=	DFN-6 (6000pcs/reel)
			MOQ = 1 reel. (Orders shipped as full reels)

### 10.2 Standard Devices

The default (unconfigured) device will be suitable for most applications. Some popular configurations are kept in stock and do not require further programming. (Ordering codes given for Device IDs: 03 0D / 03 0E or later (the Device ID will be read in USBProg2.exe)).

*Table 10.1: IQS127D Standard Replacements*

Device	IQS127D Function
IQS227(B/D)-00400008DNR/TSR	Default
IQS227(B/D)-00400028DNR/TSR	Active HIGH outputs
IQS227(B/D)-00410008DNR/TSR	Normal Power Mode
IQS227(B/D)-00400088DNR/TSR	Touch Output ac Toggle



### 10.3 Device Marking - Top

#### 10.3.1 TSOT23-6 Package Markings

There are 2 marking versions in circulation for the IQS227B/D:

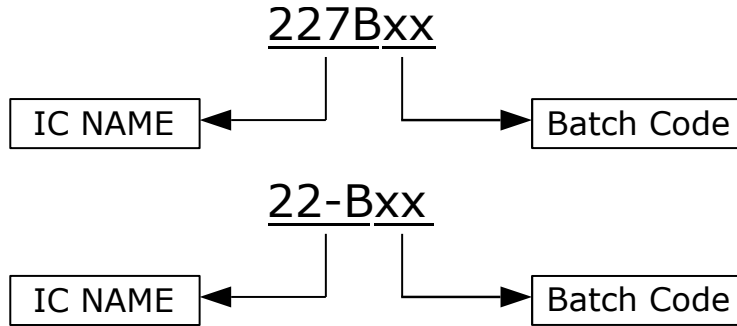

Figure 10.1: Top Marking Variants of IQS227B TSOT23-6 Package

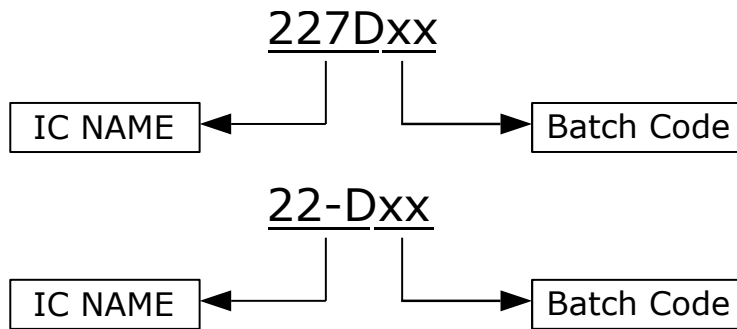

Figure 10.2: Top Marking Variants of IQS227D TSOT23-6 Package

<b>IC NAME</b>	227B	=	Self Capacitive IC with Dual Outputs (3.3V)
	22-B	=	Self Capacitive IC with Dual Outputs (3.3V)
	227D	=	Self Capacitive IC with Dual Outputs (5V)
	22-D	=	Self Capacitive IC with Dual Outputs (5V)
<b>Batch Code</b>	xx	=	AA to ZZ



### 10.3.2 WLCSP-8 Package Markings

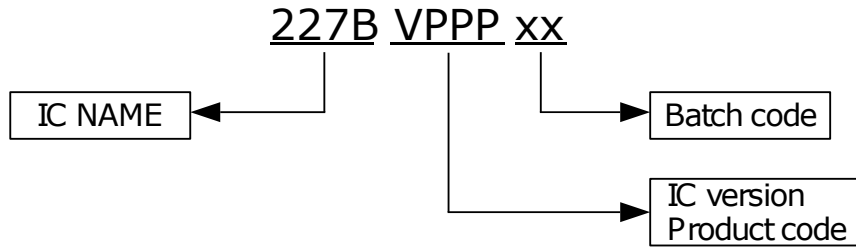

Figure 10.3: Top Marking of IQS227B WLCSP Package

<b>IC NAME</b>	227B	=	Self Capacitive IC with Dual Outputs (3.3V)
<b>Batch Code</b>	xx	=	AA - ZZ
<b>IC VERSION</b>	V		
<b>Product Code</b>	PPP		

### 10.3.3 DFN-6 Package Markings

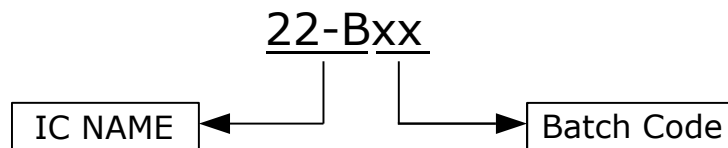

Figure 10.4: Top Marking of IQS227B DFN-6 Package

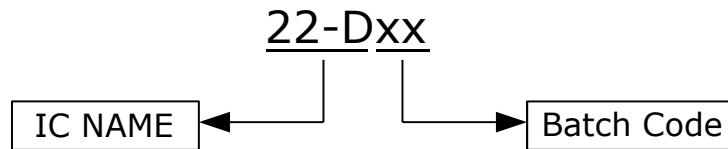

Figure 10.5: Top Marking of IQS227D DFN-6 Package

<b>IC NAME</b>	22-B	=	IQS227B Self Capacitive IC with Dual Outputs (3.3V)
	22-D	=	IQS227D Self Capacitive IC with Dual Outputs (5V)
<b>Batch Code</b>	xx	=	AA to ZZ



### 10.3.4 Tape and Reel Specification

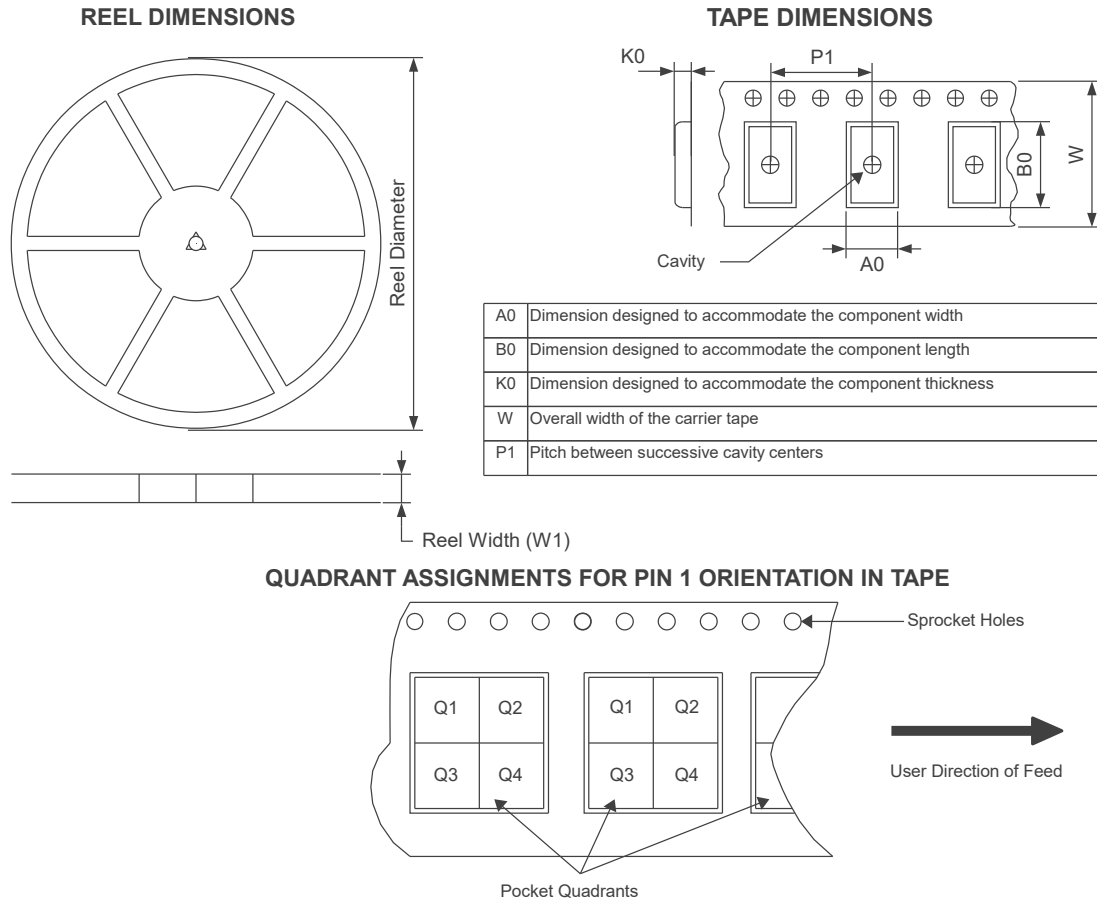

Figure 10.6: DFN-6 Tape Specification

Table 10.2: Tape and Reel Dimensions

Device	Package Type	Package Drawing	Pins	QTY per reel	Reel Diameter (mm)	Reel Width W1 (mm)	A0 (mm)	B0 (mm)	K0 (mm)	P1 (mm)	W (mm)	Pin1 Quadrant
<b>IQS227B</b>												
IQS227BzzzzzzzTSR	TSOT23-6	TSOT23-6	6	3000	178	9.5	3.1	3.1	1.3	4	8	Q3
IQS227BzzzzzzzCSR	WLCSP8	WLCSP-8	8	3000	179	8.4	1	1.55	0.48	4	8	Q3
IQS227BzzzzzzzDNR	DFN6	DFN-6	6	6000	330	12	2.8	3.3	1.2	4	12	Q1
<b>IQS227D</b>												
IQS227DzzzzzzzDNR	DFN6	DFN-6	6	6000	330	12	2.8	3.3	1.2	4	12	Q1
IQS227DzzzzzzzTSR	TSOT23-6	TSOT23-6	6	3000	178	9.5	3.1	3.1	1.3	4	8	Q3



## 11 Known Issues

### 11.1 Undebounced touch without debounced proximity flag set

When a touch flag is set without the debounced proximity flag set, the LTA will reseed to the count value, quickly clearing the touch event. This effect is most pronounced with touch buttons and gives missed touches with rapidly repeated touches.

#### **Workaround:**

- > Ensure the proximity threshold and touch threshold are as far apart as the application and features allow it.
- > The effect is less noticeable if the focus of the application is on Proximity or Touch alone instead of both.



## A Memory Map

### Device Information

00H		<b>Product Number (PROD_NR)</b>							
		Bit	7	6	5	4	3	2	1
Access		Value							
R		39 (Decimal)							
		Note							

01H		<b>Software Number (SW_NR)</b>							
		Bit	7	6	5	4	3	2	1
Access		Value							
R		28 (Decimal)							
		Note							

#### [00H] PROD\_NR

The product number for the IQS227B/D is 39 (Decimal).

#### [01H] SW\_NR

The software version number of the device ROM can be read in this byte. The latest software version is 28 (Decimal).

10H		<b>System Flags (Sys_Flags)</b>								
		Bit	7	6	5	4	3	2	1	0
Access		Value	~	~	Logic	Halt	LP	ATI	~	Zoom
R		Note								

#### [10H] SYSFLAGS0

- Bit 7-6:** **Reserved**
- Bit 5:** **Logic:** Logic Output Indication.  
0 = Active Low  
1 = Active High
- Bit 4:** **Halt:** Indicates Filter Halt Status.  
0 = LTA not being Halted  
1 = LTA Halted
- Bit 3:** **LP:** Low Power Mode  
0 = Sample time BP  
1 = Sample time LP



**Bit 2:** **ATI:** Status of automated ATI routine.

0 = ATI is not busy

1 = ATI in progress

**Bit 1:** **Reserved**

**Bit 0:** **Zoom:** Zoom will indicate full-speed charging once an undebounced proximity is detected. In BP mode, this will not change the charging frequency.

0 = IC not zoomed in

1 = IC detected undebounced proximity and IC is charging at full speed (BP)

**31H**

**Status**

		Status							
		7	6	5	4	3	2	1	0
Access	Value	~	~	~	~	~	~	Touch	Prox
	Note								
	<b>R</b>								

**[31H] Status**

**Bit 7-2:** **Reserved**

**Bit 1:** **Touch:** Touch Detection.

0 = Not Active

1 = Active

**Bit 0:** **Prox:** Proximity Detection.

0 = Not Active

1 = Active

**42H**

**Counts\_High (CS\_H)**

		Counts_High (CS_H)							
		7	6	5	4	3	2	1	0
Access	Value	Counts High Byte							
	Note								
	<b>R</b>								

**43H**

**Counts\_Low (CS\_L)**

		Counts_Low (CS_L)							
		7	6	5	4	3	2	1	0
Access	Value	Counts Low Byte							
	Note								
	<b>R</b>								



83H

**LTA\_High (LTA\_H)**

Bit	7	6	5	4	3	2	1	0
Value	Long Term Average High Byte							
Note								

Access

R

84H

**LTA\_Low (LTA\_L)**

Bit	7	6	5	4	3	2	1	0
Value	Long Term Average Low Byte							
Note								

Access

R

C4H

**Fuse Bank 0 (FB\_0)**

Bit	7	6	5	4	3	2	1	0
Value	See Table 4.1 for more details							
Note								

Access

R

C5H

**Fuse Bank 1 (FB\_1)**

Bit	7	6	5	4	3	2	1	0
Value	See Table 4.2 for more details							
Note								

Access

R

C6H

**Fuse Bank 2 (FB\_2)**

Bit	7	6	5	4	3	2	1	0
Value	See Table 4.3 for more details							
Note								

Access

R

C7H

**Fuse Bank 3 (FB\_3)**

Bit	7	6	5	4	3	2	1	0
Value	Not Used							
Note								

Access

R

C8H

**DEFAULT\_COMMS\_POINTER**

Bit	7	6	5	4	3	2	1	0
Value	(Beginning of Device Specific Data)							
Default	10H							

Access

R/W



### **[C8H] Default Comms Pointer**

The value stored in this register will be loaded into the Comms Pointer at the start of a communication window. For example, if the design only requires the Proximity Status information each cycle, then the Default Comms Pointer can be set to **ADDRESS 31H**. This would mean that at the start of each communication window, the comms pointer would already be set to the Proximity Status register, simply allowing a **READ** to retrieve the data, without the need of setting up the address.



## Contact Information

	USA	Asia	South Africa
<b>Physical Address</b>	11940 Jollyville Suite 120-S Austin TX 78759 USA	Room 501A, Block A T-Share International Centre Taoyuan Road, Nanshan District Shenzhen, Guangdong, PRC	1 Bergsig Avenue Paarl 7646 South Africa
<b>Postal Address</b>	11940 Jollyville Suite 120-S Austin TX 78759 USA	Room 501A, Block A T-Share International Centre Taoyuan Road, Nanshan District Shenzhen, Guangdong, PRC	PO Box 3534 Paarl 7620 South Africa
<b>Tel</b>	+1 512 538 1995	+86 755 8303 5294 ext 808	+27 21 863 0033
<b>Email</b>	info@azoteq.com	info@azoteq.com	info@azoteq.com

*Visit [www.azoteq.com](http://www.azoteq.com)  
for a list of distributors and worldwide representation.*

Patents as listed on [www.azoteq.com/patents-trademarks/](http://www.azoteq.com/patents-trademarks/) may relate to the device or usage of the device.

Azoteq®, Crystal Driver®, IQ Switch®, ProxSense®, ProxFusion®, LightSense™, SwipeSwitch™, and the  logo are trademarks of Azoteq.

The information in this Datasheet is believed to be accurate at the time of publication. Azoteq uses reasonable effort to maintain the information up-to-date and accurate, but does not warrant the accuracy, completeness or reliability of the information contained herein. All content and information are provided on an “as is” basis only, without any representations or warranties, express or implied, of any kind, including representations about the suitability of these products or information for any purpose. Azoteq disclaims all warranties and conditions with regard to these products and information, including but not limited to all implied warranties and conditions of merchantability, fitness for a particular purpose, title and non-infringement of any third party intellectual property rights. Azoteq assumes no liability for any damages or injury arising from any use of the information or the product or caused by, without limitation, failure of performance, error, omission, interruption, defect, delay in operation or transmission, even if Azoteq has been advised of the possibility of such damages. The applications mentioned herein are used solely for the purpose of illustration and Azoteq makes no warranty or representation that such applications will be suitable without further modification, nor recommends the use of its products for application that may present a risk to human life due to malfunction or otherwise. Azoteq products are not authorized for use as critical components in life support devices or systems. No licenses to patents are granted, implicitly, express or implied, by estoppel or otherwise, under any intellectual property rights. In the event that any of the abovementioned limitations or exclusions does not apply, it is agreed that Azoteq’s total liability for all losses, damages and causes of action (in contract, tort (including without limitation, negligence) or otherwise) will not exceed the amount already paid by the customer for the products. Azoteq reserves the right to alter its products, to make corrections, deletions, modifications, enhancements, improvements and other changes to the content and information, its products, programs and services at any time or to move or discontinue any contents, products, programs or services without prior notification. For the most up-to-date information and binding Terms and Conditions please refer to [www.azoteq.com](http://www.azoteq.com).