

## 7-Port AVB/TSN Gigabit Ethernet Switch with Integrated CPU and 100BASE-T1 PHYs

### Highlights

- Up to 5x 100BASE-T1 ports
- 1x 100BASE-TX port (LAN9382/LAN9384 only)
- Up to 3x RGMII/RMII/MII, 1x (1G/2.5G) SGMII port
- 300MHz ARM Cortex M7 CPU subsystem
- Integrated 2MB flash code memory
- Hardware security engine
- Cascade mode for higher port count with LAN937x or LAN938x families
- Enhanced EMC performance
- Full AVB Audio Video Bridging
- Time Sensitive Networking Support
- OPEN Alliance TC10 Sleep/Wakeup
- LinkMD®+ enhanced cable diagnostics
- FlexPWR® technology power management
- Small-footprint 128-pin TQFP (14 x 14 mm) package
- AEC-Q100 automotive product qualification
- Grade 2 Automotive temperature (-40°C to +105°C)
- Functional safety ready

### Target Applications

- Advanced Driver-Assistance Systems (ADAS)
- Infotainment
- Telematics & Smart Antennas
- In-Vehicle Backbone
- Gateways

### Features

- Switch Management Capabilities
  - Full wire-speed, non-blocking Gigabit switch core
  - Compliant to OPEN TC11 switch requirements
  - <140ms "Ethernet Ready" time, with secure boot
  - 1K MAC table
  - IEEE 802.1Q VLAN support
  - AVB and TSN hardware support:
    - IEEE 802.1AS time synchronization
    - IEEE 1588v2 PTP and clock synchronization
    - IEEE 802.Qav traffic shaping
    - IEEE 802.1Qbv (TSN) time-aware scheduler
    - IEEE 802.1Qci (TSN) ingress filtering and policing
    - IEEE 802.1QCB (TSN) frame replication and elimination
  - 8 shapers per port, one for each queue
  - Smart low-latency cut-through forwarding mode
  - Deep Packet Inspection (DPI) using TCAM
    - TCAM classification of Layers 2,3,4 and beyond

- Up to 5x Integrated 100BASE-T1 Ethernet PHYs (4x for LAN9381/LAN9382, 5x for LAN9383/LAN9384)
  - Compliant with IEEE 802.3bw-2015
  - 100Mbps over single balanced twisted pair cable
  - Extended cable reach >15m
  - On-chip filtering & termination for balanced UTP cable
- 1x Integrated 100BASE-TX/10BASE-T Port (LAN9382/LAN9384 only)
  - Compliant with IEEE 802.3/802.3u
  - Auto-negotiation and Auto-MDI/MDI-X support
  - On-chip termination resistors and internal biasing
- Up to 3x Configurable External MAC Ports
  - Reduced Gigabit Media Independent Interface (RGMII)
  - Reduced Media Independent Interface (RMII) with 50MHz reference clock input/output option
  - Media Independent Interface (MII) in PHY/MAC mode
  - Serial Gigabit Media Independent Interface (SGMII)
- IEEE 1588v2 PTP and Clock Synchronization
  - Transparent Clock (TC) with auto correction update
  - Master and slave Ordinary Clock (OC) support
  - End-to-end (E2E) or peer-to-peer (P2P)
  - PTP multicast and unicast message support
  - PTP message transport over IPv4/v6 and IEEE 802.3
  - IEEE 1588v2 PTP packet filtering
  - Time Aware Precision GPIO
- CPU Subsystem
  - 300MHz ARM Cortex M7 CPU
  - 64KB immutable ROM
  - 768KB RAM with configurable ITCM and DTCM (32KB to 512KB)
  - 2MB flash
  - 2x SPI master/slave controllers
  - I<sup>2</sup>C interface
  - Secure I<sup>2</sup>C EEPROM configuration
  - Secure JTAG implementation
- Advanced Diagnostics
  - OPEN Alliance (TC1) advanced diagnostics compliant
  - LinkMD®+ cable diagnostic capabilities
    - Determines cable opens/shorts/length (TX & T1)
    - Signal Quality Indicator (SQI) with MSE, peak values, and peak/threshold interrupt (T1)
  - Self-test packet generator/detector
  - Loopback modes
  - Extended MIB performance counters
- EtherGREEN™ Energy Efficiency
  - Low-power 100BASE-T1 PHY technology
  - OPEN Alliance TC10 sleep/wakeup (partial networking)
  - Non-TC10 link partner energy detect wake-up support
- Low RF Emissions
  - Integrated transmission filtering
  - xMII data and 125MHz clock prog. slew rate control
  - OPEN Alliance (TC6) RGMII EPL compliant
  - Exceeds OPEN Alliance Transceiver EMC Test Spec.

# LAN9381/2/3/4

---

- Hardware Security Engine
  - SHA256/512 Digest Engine (for fast secure boot)
  - ECDSA cryptographic accelerator
  - Optional firmware code (AES-128/256) encryption/decryption in Flash
  - OTP immutable key storage
  - Truly immutable boot ROM implemented in physical hardware ROM
  - Re-flashing over Ethernet port for OTA (Over The Air) updates
  - Optional TA100 Trust Anchor support
  - Deep packet inspection support for every packet/port
  - IEEE 802.1AR (802.1x) port and MAC authentication
  - IEEE 802.1Qci per stream ingress filtering & policing
- Functional Safety Ready
  - Fault diagnostic safety features include:
    - System clock monitor with standby clock switchover
    - Memory check with fault injection
    - ECC RAM
    - Self test on boot with fault injection
    - Gap free over and under voltage detection with interrupt
    - SHA-256 secure boot
    - Performance monitoring counters
    - IEEE 802.1CB frame replication and elimination support
    - Cable diagnostics (opens/shorts/distance)
    - SQI (receive signal quality monitoring)
  - Collateral support includes Safety Manual and FMEDA calculator (on request)

## TO OUR VALUED CUSTOMERS

It is our intention to provide our valued customers with the best documentation possible to ensure successful use of your Microchip products. To this end, we will continue to improve our publications to better suit your needs. Our publications will be refined and enhanced as new volumes and updates are introduced.

If you have any questions or comments regarding this publication, please contact the Marketing Communications Department via E-mail at [docerrors@microchip.com](mailto:docerrors@microchip.com). We welcome your feedback.

### Most Current Documentation

To obtain the most up-to-date version of this documentation, please register at our Worldwide Web site at:

<http://www.microchip.com>

You can determine the version of a data sheet by examining its literature number found on the bottom outside corner of any page. The last character of the literature number is the version number, (e.g., DS30000000A is version A of document DS30000000).

### Errata

An errata sheet, describing minor operational differences from the data sheet and recommended workarounds, may exist for current devices. As device/documentation issues become known to us, we will publish an errata sheet. The errata will specify the revision of silicon and revision of document to which it applies.

To determine if an errata sheet exists for a particular device, please check with one of the following:

- Microchip's Worldwide Web site; <http://www.microchip.com>
- Your local Microchip sales office (see last page)

When contacting a sales office, please specify which device, revision of silicon and data sheet (include -literature number) you are using.

### Customer Notification System

Register on our web site at [www.microchip.com](http://www.microchip.com) to receive the most current information on all of our products.

## 1.0 INTRODUCTION

### 1.1 General Description

The Microchip LAN9381/LAN9382/LAN9383/LAN9384 (LAN938x) is a scalable, compact and cost-effective, multi-Port AVB/TSN 100BASE-T1 Ethernet Switch family based on the IEEE 802.3bw-2015 specification. The LAN938x incorporates a layer-2+ managed high-performance Ethernet switch, up to five (four for the LAN9381/2, five for the LAN9383/4) 100BASE-T1 physical layer transceivers (PHYs), up to three MAC ports, and an ARM Cortex M7 CPU subsystem. With the addition of integrated 2MB code flash memory and a hardware security engine, the LAN938x family delivers a fully integrated, single-chip AVB/TSN bridge solution. An additional IEEE 802.3/802.3u complaint 100BASE-TX (LAN9382/4 only) port is provided for applications where an integrated automotive OBD port is required. The LAN938x is available in a Grade 2 Automotive (-40°C to +105°C) temperature range and is qualified to AEC-Q100 automotive use cases such as gateways, Automated Driver-Assistance Systems (ADAS), infotainment, telematics, and in-vehicle networking.

The LAN938x fully supports the IEEE family of Audio Video Bridging (AVB) standards, which provide high Quality of Service (QoS) for latency sensitive traffic streams over Ethernet. Hardware time-stamping and time-keeping features support IEEE 802.1AS (gPTP) and IEEE 1588v2 (PTP) time synchronization. All ports feature eight egress queues and an IEEE 802.1Qav credit based traffic shaper and time aware scheduler, as per the IEEE 802.1Qbv specification. Additional Time Sensitive Networking functionality includes an IEEE 802.1Qci ingress filtering and policing engine, and IEEE 802.1CB (TSN) frame replication and elimination support.

The LAN938x can operate either as a standalone bridge or as a system co-processor with an external host CPU. The external host can manage the switch via SPI, MDIO, or an Ethernet port, in a secure manner.

Additionally, a robust assortment of EtherGREEN™ energy efficiency features are provided, including Open Alliance TC10 sleep/wakeup partial networking, non-TC10 link partner energy detect wake-up, and ultra-deep-sleep power down.

Table 1-1 provides a summary of the feature differences between members of the LAN938x device family:

**TABLE 1-1: LAN938X FAMILY FEATURE MATRIX**

Part Number	Package	# of Integrated 100BASE-T1 PHYs	100BASE-TX Ports	RGMII/RMII/MII Ports	SGMII/RGMII/RMII/MII Ports	Full AVB Support	Time Sensitive Networking Support	OPEN Alliance TC10 Sleep/Wakeup Energy Efficiency	Cascade Mode Support	AEC-Q100 Qualification	Grade 2 Automotive Temp. (-40° to 105°C)
LAN9381	128-TQFP	4	0	2	1	X	X	X	X	X	X
LAN9382	128-TQFP	4	1	1	1	X	X	X	X	X	X
LAN9383	128-TQFP	5	0	1	1	X	X	X	X	X	X
LAN9384	128-TQFP	5	1	0	1	X	X	X	X	X	X

# LAN9381/2/3/4

An internal block diagram of the LAN938x is shown in [Figure 1-1](#).

**FIGURE 1-1: INTERNAL BLOCK DIAGRAM**

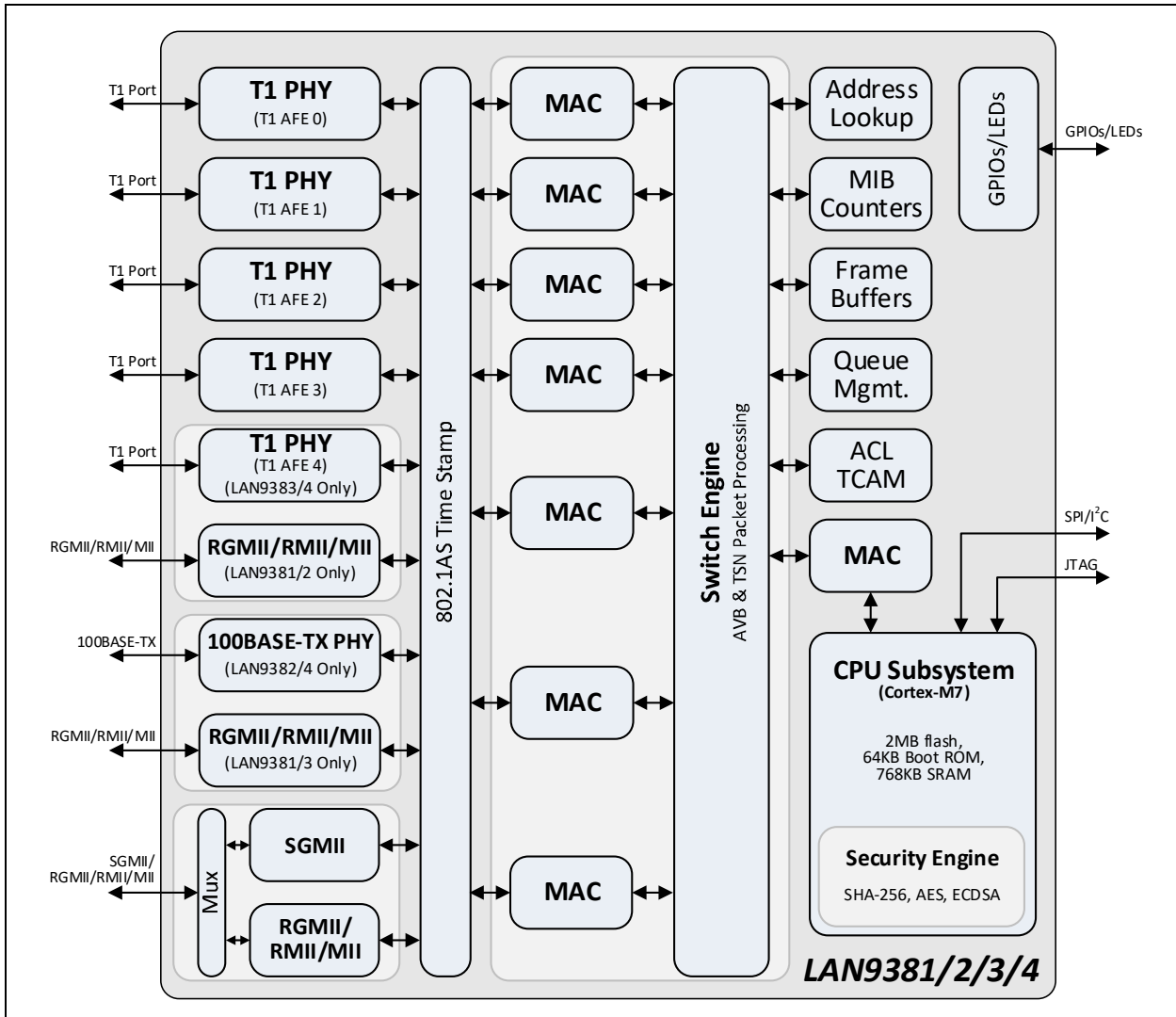

## 2.0 PACKAGE INFORMATION

### 2.1 Package Marking Information

128-TQFP-EP

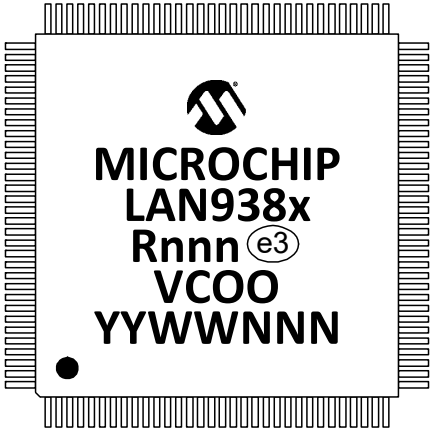

The diagram shows a square microchip package with pins on all four sides. The top edge is labeled '128-TQFP-EP'. The chip surface features the Microchip logo at the top, followed by the text 'MICROCHIP', 'LAN938x', 'Rnnn e3', 'VCOO', and 'YYWWNNN'. A small black dot is located at the bottom-left corner of the chip.

<b>Legend:</b>	x	Part number (1, 2, 3, or 4)
	R	Product revision
	nnn	Internal code
	e3	Pb-free JEDEC® designator for Matte Tin (Sn)
	V	Plant assembly
	COO	Country of origin
	YY	Year code (last two digits of calendar year)
	WW	Week code (week of January 1 is week '01')
	NNN	Alphanumeric traceability code

**Note:** In the event the full Microchip part number cannot be marked on one line, it will be carried over to the next line, thus limiting the number of available characters for customer-specific information.

\* Standard device marking consists of Microchip part number, year code, week code and traceability code. For device marking beyond this, certain price adders apply. Please check with your Microchip Sales Office. For QTP devices, any special marking adders are included in QTP price.

# LAN9381/2/3/4

## 2.2 Package Drawings

FIGURE 2-1: PACKAGE (DRAWING)

### 128-Lead Thin Quad Flatpack (6XX) - 14x14x1.0 mm Body [TQFP] With 10x10 mm Exposed Pad

**Note:** For the most current package drawings, please see the Microchip Packaging Specification located at <http://www.microchip.com/packaging>

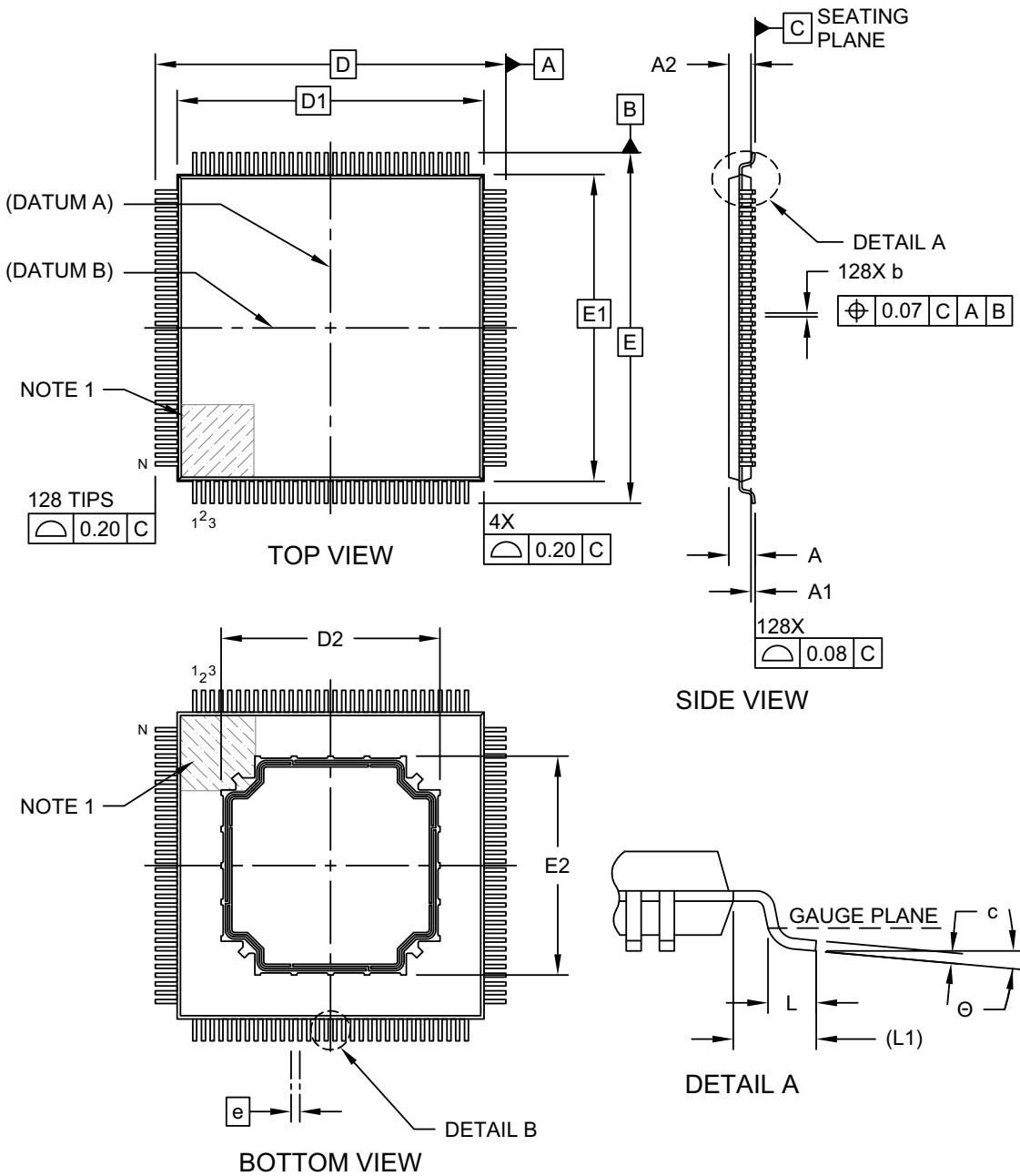

Microchip Technology Drawing C04-418B Sheet 1 of 2

**FIGURE 2-2: PACKAGE (DIMENSIONS)**

**128-Lead Thin Quad Flatpack (6XX) - 14x14x1.0 mm Body [TQFP]  
With 10x10 mm Exposed Pad**

**Note:** For the most current package drawings, please see the Microchip Packaging Specification located at <http://www.microchip.com/packaging>

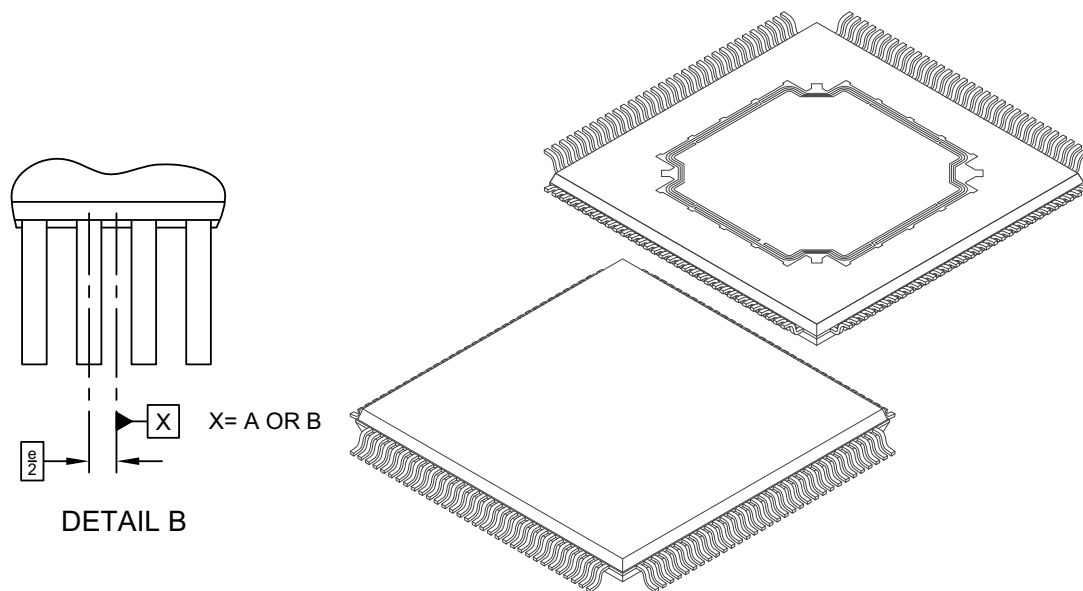

Dimension Limits	Units	MILLIMETERS		
		MIN	NOM	MAX
Number of Terminals	N	128		
Pitch	e	0.40 BSC		
Overall Height	A	-	-	1.20
Standoff	A1	0.05	-	0.15
Molded Package Thickness	A2	0.95	1.00	1.05
Overall Length	D	16.00 BSC		
Molded Package Length	D1	14.00 BSC		
Exposed Pad Length	D2	9.85	10.00	10.15
Overall Width	E	16.00 BSC		
Molded Package Width	E1	14.00 BSC		
Exposed Pad Width	E2	9.85	10.00	10.15
Terminal Width	b	0.13	0.18	0.23
Terminal Length	L	0.45	0.60	0.75
Terminal Thickness	c	0.09	-	0.20
Footprint	(L1)	1.00 REF		
Footprint Angle	Θ	0°	-	7°

**Notes:**

- Pin 1 visual index feature may vary, but must be located within the hatched area.
- Dimensioning and tolerancing per ASME Y14.5M

BSC: Basic Dimension. Theoretically exact value shown without tolerances.

REF: Reference Dimension, usually without tolerance, for information purposes only.

Microchip Technology Drawing C04-418B Sheet 2 of 2

# LAN9381/2/3/4

**FIGURE 2-3: PACKAGE (LAND PATTERN)**

**128-Lead Thin Quad Flatpack (6XX) - 14x14x1.0 mm Body [TQFP]  
With 10x10 mm Exposed Pad**

**Note:** For the most current package drawings, please see the Microchip Packaging Specification located at <http://www.microchip.com/packaging>

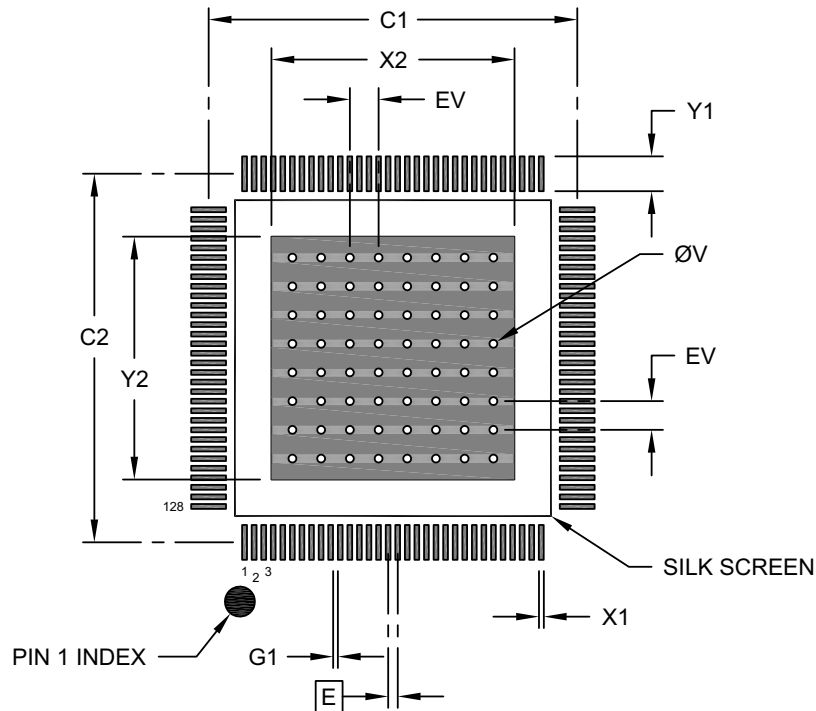

**RECOMMENDED LAND PATTERN**

Dimension Limits	Units	MILLIMETERS		
		MIN	NOM	MAX
Contact Pitch	E	0.40 BSC		
Center Pad Width	X2			10.50
Center Pad Length	Y2			10.50
Contact Pad Spacing	C1		15.40	
Contact Pad Spacing	C2		15.40	
Contact Pad Width (X128)	X1			0.20
Contact Pad Length (X128)	Y1			1.54
Contact Pad to Contact Pad (X124)	G1	0.20		
Thermal Via Diameter	V		0.33	
Thermal Via Pitch	EV		1.20	

**Notes:**

1. Dimensioning and tolerancing per ASME Y14.5M  
BSC: Basic Dimension. Theoretically exact value shown without tolerances.
2. For best soldering results, thermal vias, if used, should be filled or tented to avoid solder loss during reflow process

Microchip Technology Drawing C04-2418B

## APPENDIX A: REVISION HISTORY

TABLE A-1: REVISION HISTORY

Revision	Section/Figure/Entry	Correction
DS0003296B (01-28-20)	Features/Cover	Modified third bullet under Highlights: Changed "1 x SGMII port" to "1x (1G/2.5G) SGMII port"  Modified Hardware Security Engine as follows: Changed first bullet, "SHA256 Digest" to "SHA256/512" Digest Changed third bullet, "encryption/decryption" to "(AES-128/256) encryption/decryption"
DS0003296A (11-15-19)	Initial Document Release.	

# LAN9381/2/3/4

---

## THE MICROCHIP WEB SITE

Microchip provides online support via our WWW site at [www.microchip.com](http://www.microchip.com). This web site is used as a means to make files and information easily available to customers. Accessible by using your favorite Internet browser, the web site contains the following information:

- **Product Support** – Data sheets and errata, application notes and sample programs, design resources, user's guides and hardware support documents, latest software releases and archived software
- **General Technical Support** – Frequently Asked Questions (FAQ), technical support requests, online discussion groups, Microchip consultant program member listing
- **Business of Microchip** – Product selector and ordering guides, latest Microchip press releases, listing of seminars and events, listings of Microchip sales offices, distributors and factory representatives

## CUSTOMER CHANGE NOTIFICATION SERVICE

Microchip's customer notification service helps keep customers current on Microchip products. Subscribers will receive e-mail notification whenever there are changes, updates, revisions or errata related to a specified product family or development tool of interest.

To register, access the Microchip web site at [www.microchip.com](http://www.microchip.com). Under "Support", click on "Customer Change Notification" and follow the registration instructions.

## CUSTOMER SUPPORT

Users of Microchip products can receive assistance through several channels:

- Distributor or Representative
- Local Sales Office
- Field Application Engineer (FAE)
- Technical Support

Customers should contact their distributor, representative or field application engineer (FAE) for support. Local sales offices are also available to help customers. A listing of sales offices and locations is included in the back of this document.

**Technical support is available through the web site at: <http://www.microchip.com/support>**

## PRODUCT IDENTIFICATION SYSTEM

To order or obtain information, e.g., on pricing or delivery, refer to the factory or the listed sales office.

<u>PART NO.</u>	<u>[X]<sup>(1)</sup></u>	<u>-</u>	<u>X</u>	<u>/</u>	<u>XXX</u>	<u>XXX</u>
Device	Tape & Reel Option		Temp. Range		Package	Automotive Code
<p><b>Device:</b>            LAN9381 = 7-Port Switch (4 T1, 1 SGMII, 2 RGMII)            LAN9382 = 7-Port Switch (4 T1, 1 SGMII, 1 RGMII, 1 TX)            LAN9383 = 7-Port Switch (5 T1, 1 SGMII, 1 RGMII)            LAN9384 = 7-Port Switch (5 T1, 1 SGMII, 1 TX)</p> <p><b>Tape and Reel Option:</b>            Blank = Standard packaging (tray)            T = Tape and Reel (<a href="#">Note 1</a>)</p> <p><b>Temperature Range:</b>            -V = -40°C to +105°C (Grade 2 Automotive)</p> <p><b>Package:</b>            6XX = 128-pin TQFP-EP</p> <p><b>Automotive Code:</b>            Vxx = 3 character code with "V" prefix, specifying automotive product</p>						
<p><b>Examples:</b></p> <p>a) LAN9381-V/6XXVAO            Standard packaging,            Grade 2 Automotive temperature,            128-pin TQFP-EP package</p> <p>b) LAN9381T-V/6XXVAO            Tape &amp; reel,            Grade 2 Automotive temperature,            128-pin TQFP-EP package</p> <p>c) LAN9382-V/6XXVAO            Standard packaging,            Grade 2 Automotive temperature,            128-pin TQFP-EP package</p> <p>d) LAN9382T-V/6XXVAO            Tape &amp; reel,            Grade 2 Automotive temperature,            128-pin TQFP-EP package</p> <p>e) LAN9383-V/6XXVAO            Standard packaging,            Grade 2 Automotive temperature,            128-pin TQFP-EP package</p> <p>f) LAN9383T-V/6XXVAO            Tape &amp; reel,            Grade 2 Automotive temperature,            128-pin TQFP-EP package</p> <p>g) LAN9384-V/6XXVAO            Standard packaging,            Grade 2 Automotive temperature,            128-pin TQFP-EP package</p> <p>h) LAN9384T-V/6XXVAO            Tape &amp; reel,            Grade 2 Automotive temperature,            128-pin TQFP-EP package</p> <p><b>Note 1:</b> Tape and Reel identifier only appears in the catalog part number description. This identifier is used for ordering purposes and is not printed on the device package. Check with your Microchip Sales Office for package availability with the Tape and Reel option.</p>						

# LAN9381/2/3/4

---

## Note the following details of the code protection feature on Microchip devices:

- Microchip products meet the specification contained in their particular Microchip Data Sheet.
- Microchip believes that its family of products is one of the most secure families of its kind on the market today, when used in the intended manner and under normal conditions.
- There are dishonest and possibly illegal methods used to breach the code protection feature. All of these methods, to our knowledge, require using the Microchip products in a manner outside the operating specifications contained in Microchip's Data Sheets. Most likely, the person doing so is engaged in theft of intellectual property.
- Microchip is willing to work with the customer who is concerned about the integrity of their code.
- Neither Microchip nor any other semiconductor manufacturer can guarantee the security of their code. Code protection does not mean that we are guaranteeing the product as “unbreakable.”

Code protection is constantly evolving. We at Microchip are committed to continuously improving the code protection features of our products. Attempts to break Microchip's code protection feature may be a violation of the Digital Millennium Copyright Act. If such acts allow unauthorized access to your software or other copyrighted work, you may have a right to sue for relief under that Act.

---

Information contained in this publication regarding device applications and the like is provided only for your convenience and may be superseded by updates. It is your responsibility to ensure that your application meets with your specifications. MICROCHIP MAKES NO REPRESENTATIONS OR WARRANTIES OF ANY KIND WHETHER EXPRESS OR IMPLIED, WRITTEN OR ORAL, STATUTORY OR OTHERWISE, RELATED TO THE INFORMATION, INCLUDING BUT NOT LIMITED TO ITS CONDITION, QUALITY, PERFORMANCE, MERCHANTABILITY OR FITNESS FOR PURPOSE. Microchip disclaims all liability arising from this information and its use. Use of Microchip devices in life support and/or safety applications is entirely at the buyer's risk, and the buyer agrees to defend, indemnify and hold harmless Microchip from any and all damages, claims, suits, or expenses resulting from such use. No licenses are conveyed, implicitly or otherwise, under any Microchip intellectual property rights unless otherwise stated.

## Trademarks

The Microchip name and logo, the Microchip logo, Adaptec, AnyRate, AVR, AVR logo, AVR Freaks, BesTime, BitCloud, chipKIT, chipKIT logo, CryptoMemory, CryptoRF, dsPIC, FlashFlex, flexPWR, HELDO, IGLOO, JukeBlox, KeeLoq, Kleer, LANCheck, LinkMD, maXStylus, maXTouch, MediaLB, megaAVR, Microsemi, Microsemi logo, MOST, MOST logo, MPLAB, OptoLyzer, PackeTime, PIC, picoPower, PICSTART, PIC32 logo, PolarFire, Prochip Designer, QTouch, SAM-BA, SenGenuity, SpyNIC, SST, SST Logo, SuperFlash, Symmetricom, SyncServer, Tachyon, TempTracker, TimeSource, tinyAVR, UNI/O, Vectron, and XMEGA are registered trademarks of Microchip Technology Incorporated in the U.S.A. and other countries.

APT, ClockWorks, The Embedded Control Solutions Company, EtherSynch, FlashTec, Hyper Speed Control, HyperLight Load, IntelliMOS, Libero, motorBench, mTouch, Powermite 3, Precision Edge, ProASIC, ProASIC Plus, ProASIC Plus logo, Quiet-Wire, SmartFusion, SyncWorld, Temux, TimeCesium, TimeHub, TimePictra, TimeProvider, Vite, WinPath, and ZL are registered trademarks of Microchip Technology Incorporated in the U.S.A.

Adjacent Key Suppression, AKS, Analog-for-the-Digital Age, Any Capacitor, AnyIn, AnyOut, BlueSky, BodyCom, CodeGuard, CryptoAuthentication, CryptoAutomotive, CryptoCompanion, CryptoController, dsPICDEM, dsPICDEM.net, Dynamic Average Matching, DAM, ECAN, EtherGREEN, In-Circuit Serial Programming, ICSP, INICnet, Inter-Chip Connectivity, JitterBlocker, KleerNet, KleerNet logo, memBrain, Mindi, MiWi, MPASM, MPF, MPLAB Certified logo, MPLIB, MPLINK, MultiTRAK, NetDetach, Omniscient Code Generation, PICDEM, PICDEM.net, PICkit, PICtail, PowerSmart, PureSilicon, QMatrix, REAL ICE, Ripple Blocker, SAM-ICE, Serial Quad I/O, SMART-I.S., SQI, SuperSwitcher, SuperSwitcher II, Total Endurance, TSHARC, USBCheck, VariSense, ViewSpan, WiperLock, Wireless DNA, and ZENA are trademarks of Microchip Technology Incorporated in the U.S.A. and other countries.

SQTP is a service mark of Microchip Technology Incorporated in the U.S.A.

The Adaptec logo, Frequency on Demand, Silicon Storage Technology, and Symmcom are registered trademarks of Microchip Technology Inc. in other countries.

GestIC is a registered trademark of Microchip Technology Germany II GmbH & Co. KG, a subsidiary of Microchip Technology Inc., in other countries.

All other trademarks mentioned herein are property of their respective companies.

© 2019-2020, Microchip Technology Incorporated, All Rights Reserved.

ISBN: 9781522455516

*For information regarding Microchip's Quality Management Systems, please visit [www.microchip.com/quality](http://www.microchip.com/quality).*



# MICROCHIP

## Worldwide Sales and Service

### AMERICAS

**Corporate Office**  
2355 West Chandler Blvd.  
Chandler, AZ 85224-6199  
Tel: 480-792-7200  
Fax: 480-792-7277  
Technical Support:  
<http://www.microchip.com/support>  
Web Address:  
[www.microchip.com](http://www.microchip.com)

**Atlanta**  
Duluth, GA  
Tel: 678-957-9614  
Fax: 678-957-1455

**Austin, TX**  
Tel: 512-257-3370

**Boston**  
Westborough, MA  
Tel: 774-760-0087  
Fax: 774-760-0088

**Chicago**  
Itasca, IL  
Tel: 630-285-0071  
Fax: 630-285-0075

**Dallas**  
Addison, TX  
Tel: 972-818-7423  
Fax: 972-818-2924

**Detroit**  
Novi, MI  
Tel: 248-848-4000

**Houston, TX**  
Tel: 281-894-5983

**Indianapolis**  
Noblesville, IN  
Tel: 317-773-8323  
Fax: 317-773-5453  
Tel: 317-536-2380

**Los Angeles**  
Mission Viejo, CA  
Tel: 949-462-9523  
Fax: 949-462-9608  
Tel: 951-273-7800

**Raleigh, NC**  
Tel: 919-844-7510

**New York, NY**  
Tel: 631-435-6000

**San Jose, CA**  
Tel: 408-735-9110  
Tel: 408-436-4270

**Canada - Toronto**  
Tel: 905-695-1980  
Fax: 905-695-2078

### ASIA/PACIFIC

**Australia - Sydney**  
Tel: 61-2-9868-6733

**China - Beijing**  
Tel: 86-10-8569-7000

**China - Chengdu**  
Tel: 86-28-8665-5511

**China - Chongqing**  
Tel: 86-23-8980-9588

**China - Dongguan**  
Tel: 86-769-8702-9880

**China - Guangzhou**  
Tel: 86-20-8755-8029

**China - Hangzhou**  
Tel: 86-571-8792-8115

**China - Hong Kong SAR**  
Tel: 852-2943-5100

**China - Nanjing**  
Tel: 86-25-8473-2460

**China - Qingdao**  
Tel: 86-532-8502-7355

**China - Shanghai**  
Tel: 86-21-3326-8000

**China - Shenyang**  
Tel: 86-24-2334-2829

**China - Shenzhen**  
Tel: 86-755-8864-2200

**China - Suzhou**  
Tel: 86-186-6233-1526

**China - Wuhan**  
Tel: 86-27-5980-5300

**China - Xian**  
Tel: 86-29-8833-7252

**China - Xiamen**  
Tel: 86-592-2388138

**China - Zhuhai**  
Tel: 86-756-3210040

### ASIA/PACIFIC

**India - Bangalore**  
Tel: 91-80-3090-4444

**India - New Delhi**  
Tel: 91-11-4160-8631

**India - Pune**  
Tel: 91-20-4121-0141

**Japan - Osaka**  
Tel: 81-6-6152-7160

**Japan - Tokyo**  
Tel: 81-3-6880-3770

**Korea - Daegu**  
Tel: 82-53-744-4301

**Korea - Seoul**  
Tel: 82-2-554-7200

**Malaysia - Kuala Lumpur**  
Tel: 60-3-7651-7906

**Malaysia - Penang**  
Tel: 60-4-227-8870

**Philippines - Manila**  
Tel: 63-2-634-9065

**Singapore**  
Tel: 65-6334-8870

**Taiwan - Hsin Chu**  
Tel: 886-3-577-8366

**Taiwan - Kaohsiung**  
Tel: 886-7-213-7830

**Taiwan - Taipei**  
Tel: 886-2-2508-8600

**Thailand - Bangkok**  
Tel: 66-2-694-1351

**Vietnam - Ho Chi Minh**  
Tel: 84-28-5448-2100

### EUROPE

**Austria - Wels**  
Tel: 43-7242-2244-39  
Fax: 43-7242-2244-393

**Denmark - Copenhagen**  
Tel: 45-4450-2828  
Fax: 45-4485-2829

**Finland - Espoo**  
Tel: 358-9-4520-820

**France - Paris**  
Tel: 33-1-69-53-63-20  
Fax: 33-1-69-30-90-79

**Germany - Garching**  
Tel: 49-8931-9700

**Germany - Haan**  
Tel: 49-2129-3766400

**Germany - Heilbronn**  
Tel: 49-7131-72400

**Germany - Karlsruhe**  
Tel: 49-721-625370

**Germany - Munich**  
Tel: 49-89-627-144-0  
Fax: 49-89-627-144-44

**Germany - Rosenheim**  
Tel: 49-8031-354-560

**Israel - Ra'anana**  
Tel: 972-9-744-7705

**Italy - Milan**  
Tel: 39-0331-742611  
Fax: 39-0331-466781

**Italy - Padova**  
Tel: 39-049-7625286

**Netherlands - Drunen**  
Tel: 31-416-690399  
Fax: 31-416-690340

**Norway - Trondheim**  
Tel: 47-7288-4388

**Poland - Warsaw**  
Tel: 48-22-3325737

**Romania - Bucharest**  
Tel: 40-21-407-87-50

**Spain - Madrid**  
Tel: 34-91-708-08-90  
Fax: 34-91-708-08-91

**Sweden - Gothenberg**  
Tel: 46-31-704-60-40

**Sweden - Stockholm**  
Tel: 46-8-5090-4654

**UK - Wokingham**  
Tel: 44-118-921-5800  
Fax: 44-118-921-5820