Switchtec™ Low Lane Count PCIe® Gen4x16 Switch Family with Multi-Host Support

Features

- **High-Performance Non-Blocking Switch**

- PCIe Gen4x16 switch
- Up to 256 GB/s switching capacity
- Full line rate on all ports, 16GT/s per lane
- Ports bifurcate to x2/x4 lanes, x1 devices can be enumerated on any port
- Non-Transparent Bridge (NTB) supported for Root Complex (RC) connections
- NT address translation using direct windows and multiple sub-windows per BAR
- Configurable domains for RC ports

- **Power Management**

- Active State Power Management (ASPM)
- Software controlled power management
- Supports L0, L1, L2, L3 link states

- **PCIe Interfaces**

- Passive, managed, and optical cable support

- **Peripheral I/O Interfaces**

- SPI interface for external boot memory
- FlexCom I/O block configurable for USART, SPI, I²C & TWI
- Secure JTAG and EJTAG interface
- GPIO pins

- **Reliability and Availability**

- Advanced error reporting (AER) on all ports

- **Firmware Security**

- OEM-controlled Root of Trust for firmware and configuration signing
- Secure Boot from SPI flash
- Secure firmware updates
- Secure RMA - OEM-controlled Root of Trust for Secure JTAG interface

- **ChipLink Diagnostic Tools**

- Extensive debug, diagnostics, configuration and analysis tools with an intuitive GUI
- Access to configuration data, management capabilities, and signal integrity analysis tools (such as real-time eye capture)
- Errors, statistics, performance, and TLP latency counters
- Connects to device over in-band PCIe or sideband signals (UART and TWI)

- **Package**

- 353-ball FCCSP (16 x 16 mm) package

- **Environmental**

- Commercial temperature (0°C to +70°C)
- Industrial temperature (-40°C to +85°C)
- Automotive AEC-Q100 Qualified Grade 2 temperature (-40°C to +105°C)
(PCI1003/PCI1004 *only*)

Target Applications

- Level 2/3 Advanced Driver-Assistance Systems (ADAS)
- Defense & Aerospace Compute Applications
- Embedded Servers & Industrial PCs
- Video Acceleration Equipment

TO OUR VALUED CUSTOMERS

It is our intention to provide our valued customers with the best documentation possible to ensure successful use of your Microchip products. To this end, we will continue to improve our publications to better suit your needs. Our publications will be refined and enhanced as new volumes and updates are introduced.

If you have any questions or comments regarding this publication, please contact the Marketing Communications Department via E-mail at docerrors@microchip.com or fax the **Reader Response Form** in the back of this data sheet to (480) 792-4150. We welcome your feedback.

Most Current Data Sheet

To obtain the most up-to-date version of this data sheet, please register at our Worldwide Web site at:

<http://www.microchip.com>

You can determine the version of a data sheet by examining its literature number found on the bottom outside corner of any page. The last character of the literature number is the version number, (e.g., DS30000A is version A of document DS30000).

Errata

An errata sheet, describing minor operational differences from the data sheet and recommended workarounds, may exist for current devices. As device/documentation issues become known to us, we will publish an errata sheet. The errata will specify the revision of silicon and revision of document to which it applies.

To determine if an errata sheet exists for a particular device, please check with one of the following:

- Microchip's Worldwide Web site; <http://www.microchip.com>
- Your local Microchip sales office (see last page)

When contacting a sales office, please specify which device, revision of silicon and data sheet (include literature number) you are using.

Customer Notification System

Register on our web site at www.microchip.com to receive the most current information on all of our products.

1.0 INTRODUCTION

1.1 General Description

The low-lane count PCI100x family builds on the legacy of the high-performance Microchip Switchtec family. The PCI100x family of products offers many features of the full-size data center switches in a small lane count format, enabling PCIe connectivity and flexible system design. The smaller form factor makes the products suitable for SoC and accelerator connectivity as well as fanout of port- and lane-limited PCIe connections. The PCI Gen4 switch family is composed of a PCIe Base Specification 4.0 compliant switch supporting up to 16 lanes with Non-Transparent Bridge (NTB) options, embedded lower power states, and diagnostics and debug capabilities.

Preconfigured product variants offer options with up to 8 ports. All ports are NTB-capable, with some ports preconfigured, depending on the selected product family variant. Depending on the product selected, port lane counts are available in x2 and x4 widths. All ports can be used with reduced lane counts when required by the connecting a Root Complex (RC) or End Point (EP). Independent software domains enable direct access from RC devices to domain ports. Non-Transparent Bridging enables access to resources in other domains. “Cut-through” mode is supported for switching packets and advanced power saving features include idling of empty ports and clock removal during L1 states.

End-to-end data integrity protection and low latency performance is consistent with other Switchtec products. Typical packet latency is 120ns for port-to-port transit.

Comprehensive diagnostics and debugging are available through the ChipLink tool suite. Diagnostic capabilities include PCIe Analyzer and configurable Stack Error Counters, Eye Opening Margining, and firmware logging. Secure boot and software updates are supported.

Typical applications for the PCI100x family of products include Automotive Level 2+ and Level 3 ADAS systems, defense and aerospace compute applications, embedded servers & industrial PCs, and small video systems.

To support safety applications, the PCI100x device family is fully ISO-26262 Functional Safety compliant and carries an ASIL-B rating. Extensive PCIe reporting capabilities combine with safety monitoring features to report status of switch functionality, data movement, and node connections.

The PCI100x family of products are available in commercial (0°C to +70°C), industrial (-40°C to +85°C), and AEC Q-100 Automotive grade 2 (-40°C to +105°C) temperature range versions.

[Table 1-1](#) provides a summary of the preconfigured variances between family members, including number of ports, Upstream Facing Port (UFP) configuration, Downstream Facing Port (DFP) configuration, number of NTBs, overall number of lanes, and temperature range options.

TABLE 1-1: PCI100X FAMILY FEATURE MATRIX

Part Number	Ports	UFP Config.	DFP Config.	NTBs	Lanes	Com. Temp	Ind. Temp	Auto. Temp
PCI1001 4-Port 0-NTB PCIe Gen4x16 Fanout Switch	4	1x4 Lane Port	3x4 Lane Ports	0	16	Yes	Yes	No
PCI1003 6-Port 4-NTB PCIe Gen4x16 Switch	6	2x4 Lane Ports & 2x2 Lane Ports	2x2 Lane Ports	4	16	Yes	Yes	Yes
PCI1004 4-Port 4-NTB PCIe Gen4x16 Switch	4	4x4 Lane Ports	0	4	16	Yes	Yes	Yes
PCI1005 7-Port 0-NTB PCIe Gen4x16 Fanout Switch	7	1x4 Lane Port	6x2 Lane Ports	0	16	Yes	Yes	No

PCI100X

An Internal block diagram and typical application block diagram for each of the devices in the PCI100x family are detailed in the following sub-sections.

1.1.1 PCI1001

FIGURE 1-1: PCI1001 INTERNAL BLOCK DIAGRAM

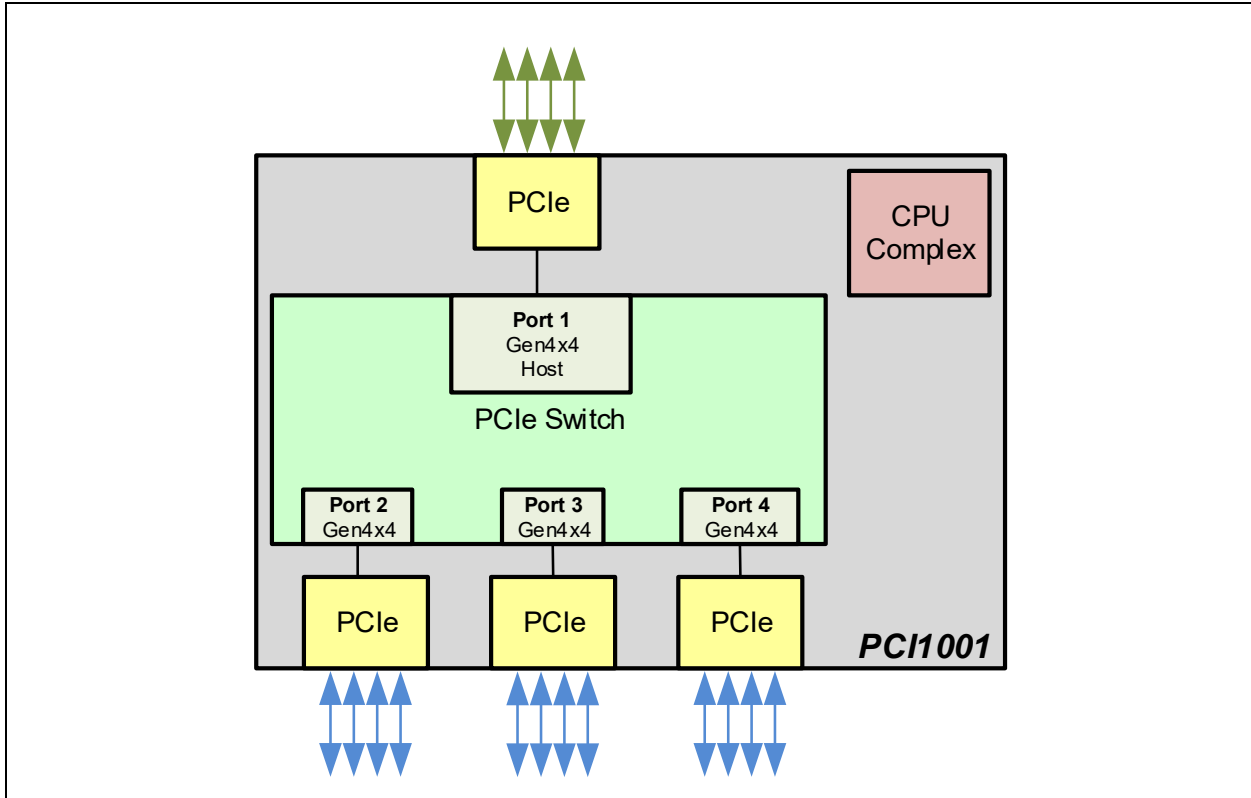

FIGURE 1-2: PCI1001 APPLICATION BLOCK DIAGRAM

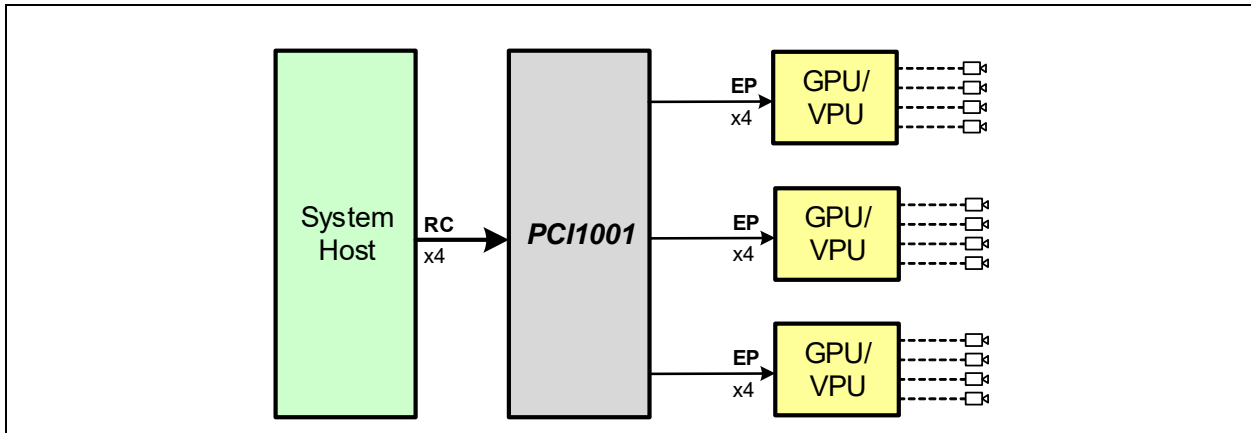

FIGURE 1-3: PCI1003 INTERNAL BLOCK DIAGRAM

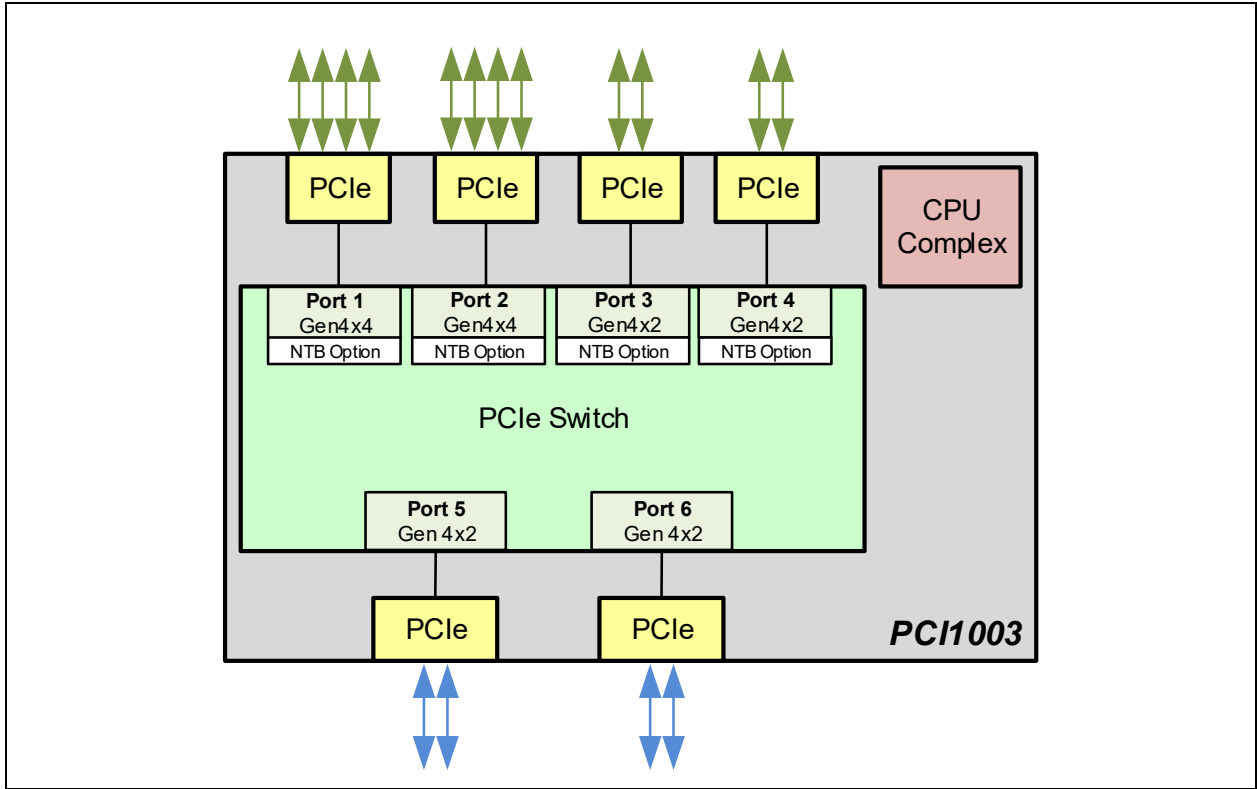
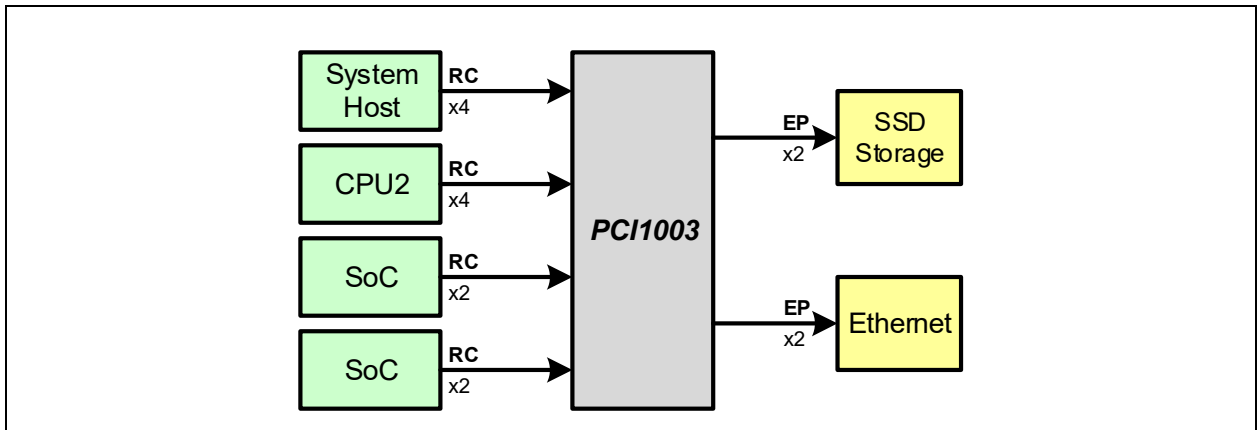

FIGURE 1-4: PCI1003 APPLICATION BLOCK DIAGRAM



PCI100X

1.1.3 PCI1004

FIGURE 1-5: PCI1004 INTERNAL BLOCK DIAGRAM

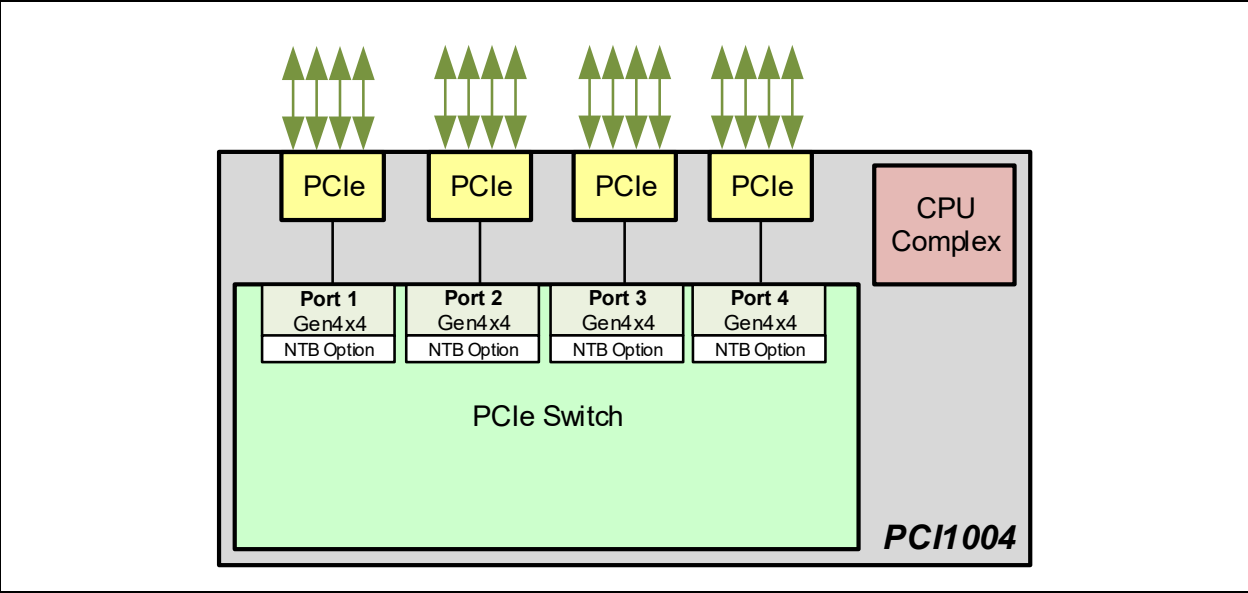

FIGURE 1-6: PCI1004 APPLICATION BLOCK DIAGRAM

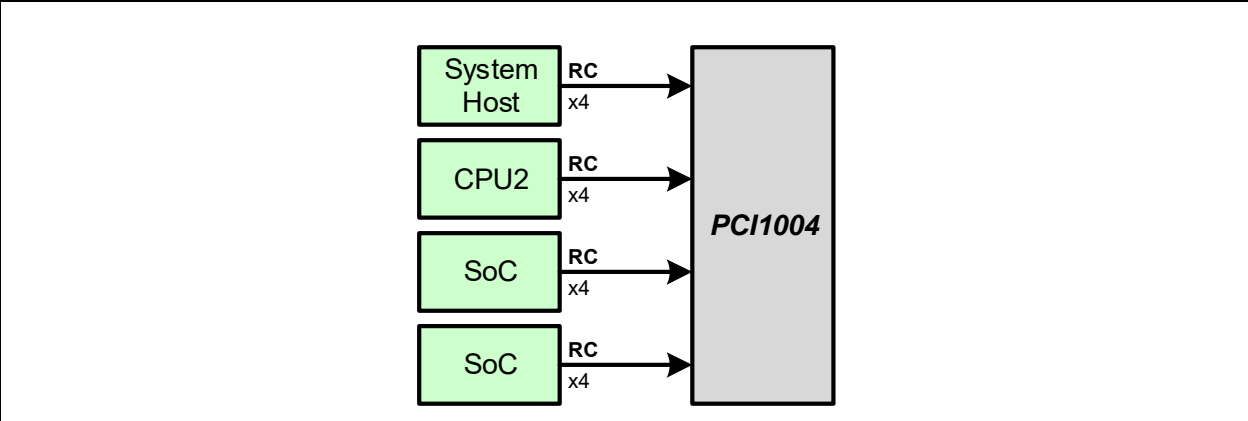

FIGURE 1-7: PCI1005 INTERNAL BLOCK DIAGRAM

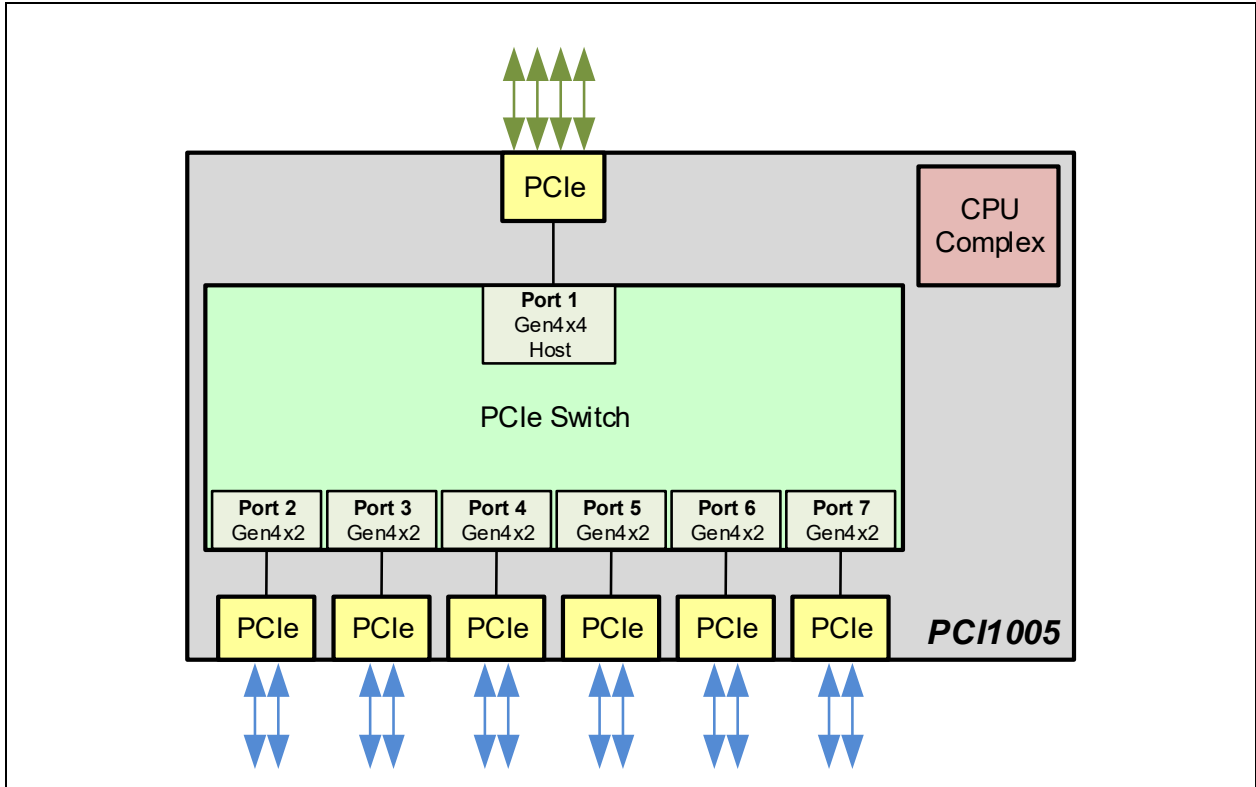
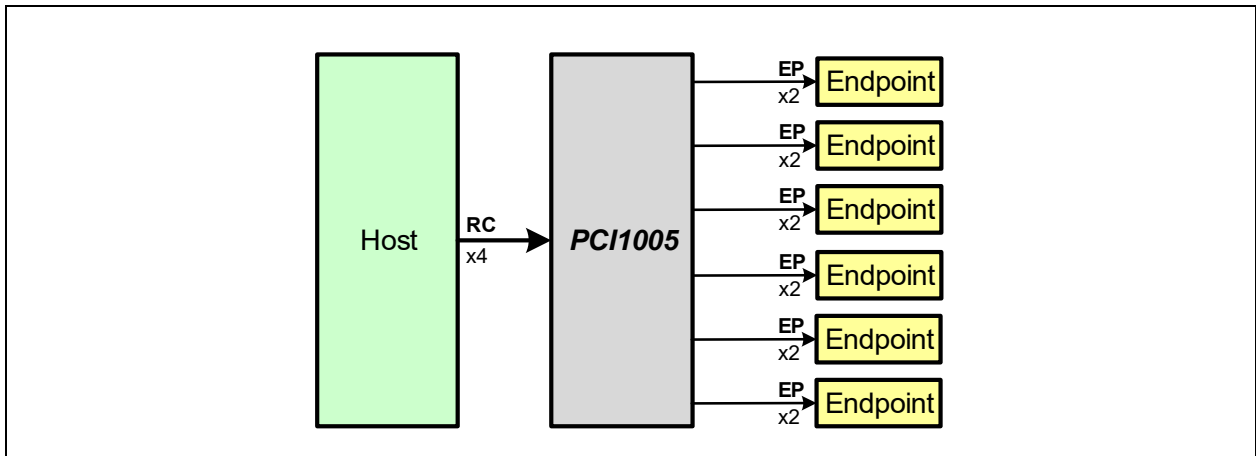

FIGURE 1-8: PCI1005 APPLICATION BLOCK DIAGRAM



PCI100X

2.0 PACKAGE INFORMATION

Note: For the most current package drawings, see the Microchip Packaging Specification at: <http://www.microchip.com/packaging>.

2.1 Package Drawing & Dimensions

FIGURE 2-1: 353-FCCSP PACKAGE (DRAWING)

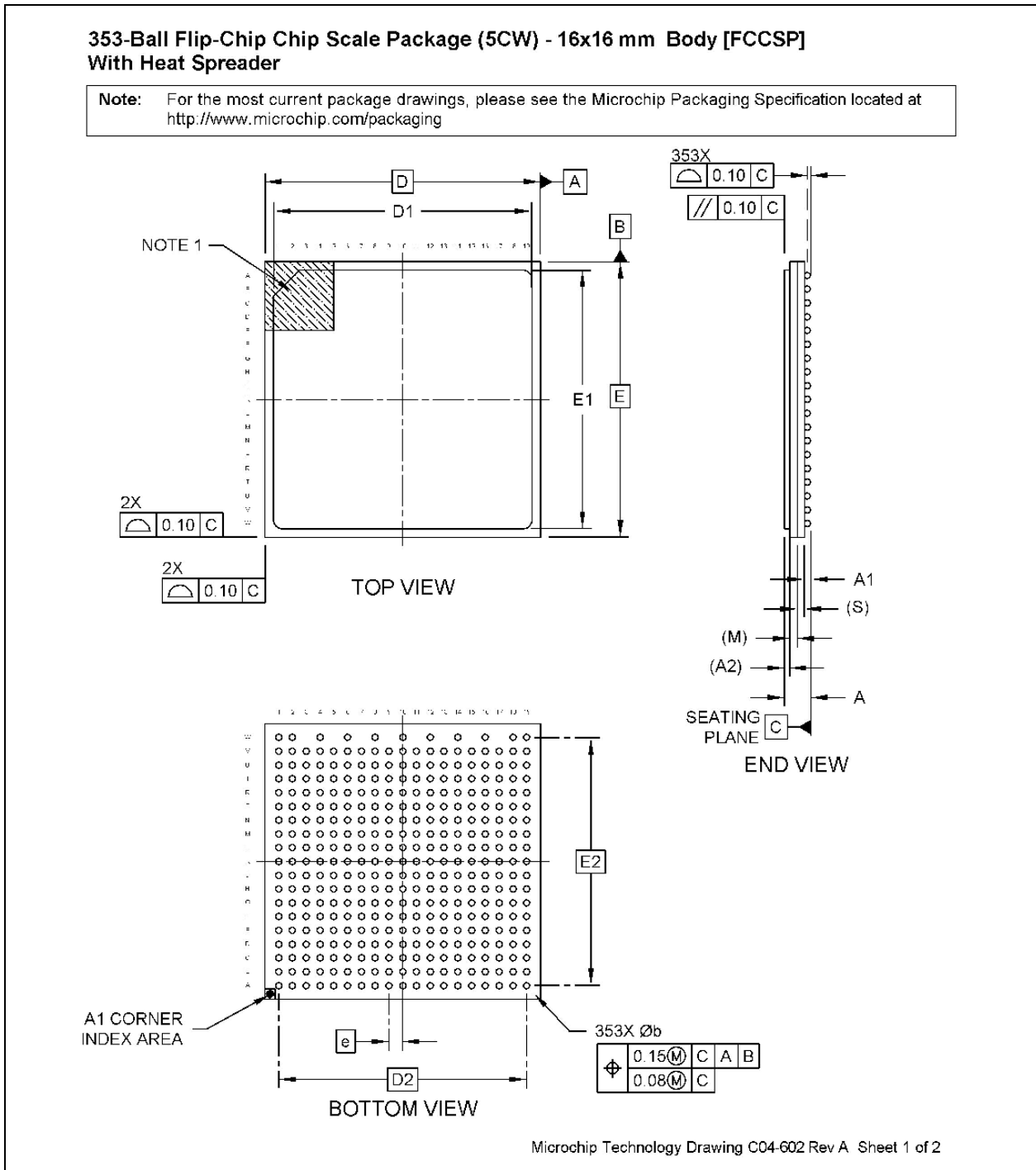
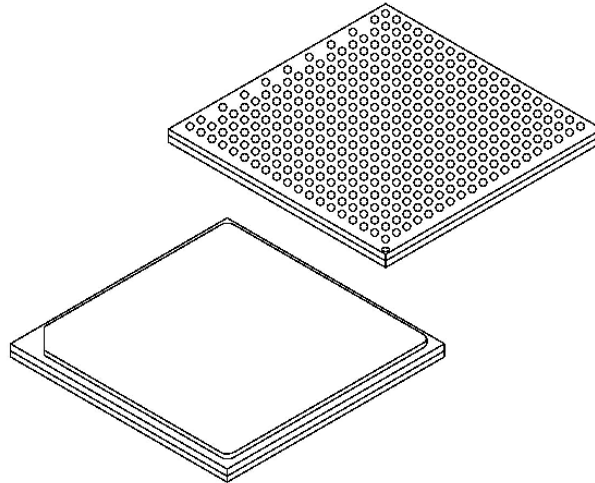

FIGURE 2-2: 353-FCCSP PACKAGE (DIMENSIONS)

**353-Ball Flip-Chip Chip Scale Package (5CW) - 16x16 mm Body [FCCSP]
With Heat Spreader**

Note: For the most current package drawings, please see the Microchip Packaging Specification located at <http://www.microchip.com/packaging>



Dimension	Units	MILLIMETERS		
		MIN	NOM	MAX
Number of Terminals	N	353 BSC		
Pitch	e	0.80 BSC		
Overall Height	A	1.34	1.44	1.54
Ball Height	A1	0.27	0.32	0.37
Heat Sink Thickness	A2	0.20 REF		
Mold Thickness	M	0.45 REF		
Substrate Thickness	S	0.41 REF		
Overall Length	D	16.00 BSC		
Heat Sink Length	D1	14.95	15.00	15.05
Ball Array Length	D2	14.40 BSC		
Overall Width	E	16.00 BSC		
Heat Sink Width	E1	14.95	15.00	15.05
Ball Array Width	E2	14.40 BSC		
Ball Diameter	b	0.36	0.41	0.46

Notes:

- Pin 1 visual index feature may vary but must be located within the hatched area.
- Package is saw singulated.
- Dimensioning and tolerancing per ASME Y14.5M
 BSC: Basic Dimension. Theoretically exact value shown without tolerances.
 REF: Reference Dimension, usually without tolerance, for information purposes only.

Microchip Technology Drawing C04-602 Rev A Sheet 2 of 2

FIGURE 2-3: 353-FCCSP PACKAGE (LAND-PATTERN)

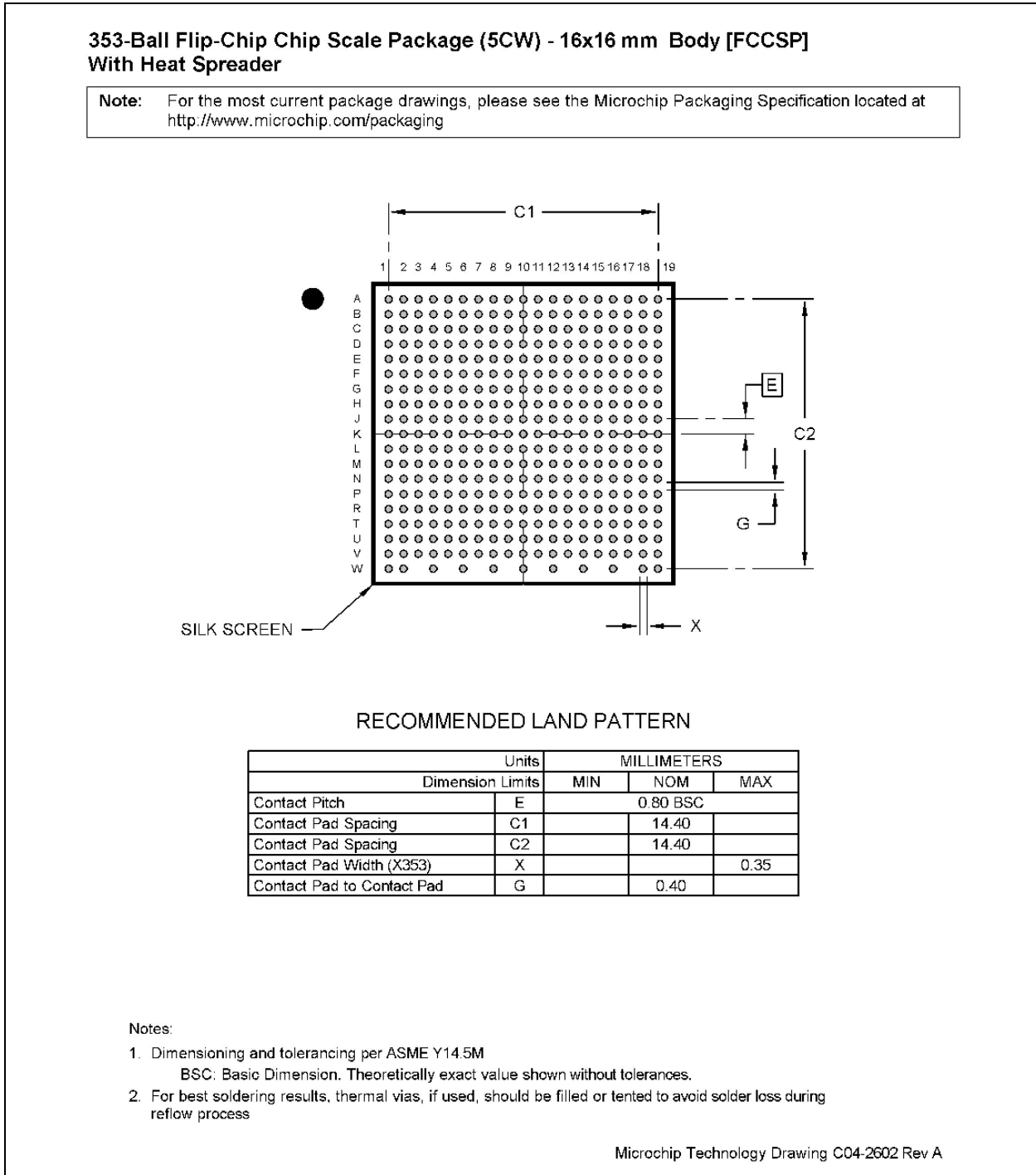

APPENDIX A: PRODUCT BRIEF REVISION HISTORY

TABLE A-1: REVISION HISTORY

Revision Level & Date	Section/Figure/Entry	Correction
DS00005055C (01-14-25)	All	<p>First public document release.</p> <p>Updated package and ordering information.</p> <p>Removed the following bullet under “High-Performance Non-Blocking Switch” shown on the cover: “Optional 4-lane cross-link port for up to 24-lanes and 6x NTB ports”</p> <p>Modified the following features on the cover:</p> <p>Power Management: Replaced “Supports L0, L1, L1.1, L1.2 power savings states” with “Supports L0, L1, L2, L3 link states”. Modified feature in ChipLink</p> <p>Diagnostic Tools: Replaced “Connects to device over in-band PCIe or sideband signals (UART, TWI and EJTAG)” with “Connects to device over in-band PCIe or sideband signals (UART and TWI)”.</p>
	All	Updated all package references from “FCBGA” to “FCCSP” throughout document.
	Section 2.1, Package Drawing & Dimensions	Updated package drawings
	Product Identification System	Updated to make consistent with datasheet layout/format.
DS00005055B (02-14-24)	All	Updated document to be in line with latest SKU matrix and package information
	Section 1.1, General Description	Added new paragraph
DS00005055A (08-07-23)	All	Initial Release

PCI100X

PRODUCT IDENTIFICATION SYSTEM

To order or obtain information, e.g., on pricing or delivery, refer to the factory or the listed sales office.

Device	Tape & Reel / Tray	Temperature Range	Package	Part Number
PCI1001 4-Port: 1x4UFP 3x4DFP 0 NTBs	Tray	0°C to +70°C (Commercial)	353-ball FCCSP (16 x 16 mm)	PCI1001/5CW
	Tray	-40°C to +85°C (Industrial)	353-ball FCCSP (16 x 16 mm)	PCI1001-I/5CW
	Tape & Reel	0°C to +70°C (Commercial)	353-ball FCCSP (16 x 16 mm)	PCI1001T/5CW
	Tape & Reel	-40°C to +85°C (Industrial)	353-ball FCCSP (16 x 16 mm)	PCI1001T-I/5CW
PCI1003 6-Port: 2x4UFP 2x2UFP 2x2DFP 4 NTBs	Tray	0°C to +70°C (Commercial)	353-ball FCCSP (16 x 16 mm)	PCI1003/5CW
	Tray	-40°C to +85°C (Industrial)	353-ball FCCSP (16 x 16 mm)	PCI1003-I/5CW
	Tray	-40°C to +105°C (AEC-Q100 Auto)	353-ball FCCSP (16 x 16 mm)	PCI1003-V/5CWVAO
	Tape & Reel	0°C to +70°C (Commercial)	353-ball FCCSP (16 x 16 mm)	PCI1003T/5CW
	Tape & Reel	-40°C to +85°C (Industrial)	353-ball FCCSP (16 x 16 mm)	PCI1003T-I/5CW
	Tape & Reel	-40°C to +105°C (AEC-Q100 Auto)	353-ball FCCSP (16 x 16 mm)	PCI1003T-V/5CWVAO
PCI1004 4-Port: 4x4UFP 4 NTBs	Tray	0°C to +70°C (Commercial)	353-ball FCCSP (16 x 16 mm)	PCI1004/5CW
	Tray	-40°C to +85°C (Industrial)	353-ball FCCSP (16 x 16 mm)	PCI1004-I/5CW
	Tray	-40°C to +105°C (AEC-Q100 Auto)	353-ball FCCSP (16 x 16 mm)	PCI1004-V/5CWVAO
	Tape & Reel	0°C to +70°C (Commercial)	353-ball FCCSP (16 x 16 mm)	PCI1004T/5CW
	Tape & Reel	-40°C to +85°C (Industrial)	353-ball FCCSP (16 x 16 mm)	PCI1004T-I/5CW
	Tape & Reel	-40°C to +105°C (AEC-Q100 Auto)	353-ball FCCSP (16 x 16 mm)	PCI1004T-V/5CWVAO
PCI1005 7-Port: 1x4UFP 6x2DFP 0 NTBs	Tray	0°C to +70°C (Commercial)	353-ball FCCSP (16 x 16 mm)	PCI1005/5CW
	Tray	-40°C to +85°C (Industrial)	353-ball FCCSP (16 x 16 mm)	PCI1005-I/5CW
	Tape & Reel	0°C to +70°C (Commercial)	353-ball FCCSP (16 x 16 mm)	PCI1005T/5CW
	Tape & Reel	-40°C to +85°C (Industrial)	353-ball FCCSP (16 x 16 mm)	PCI1005T-I/5CW

THE MICROCHIP WEB SITE

Microchip provides online support via our WWW site at www.microchip.com. This web site is used as a means to make files and information easily available to customers. Accessible by using your favorite Internet browser, the web site contains the following information:

- **Product Support** – Data sheets and errata, application notes and sample programs, design resources, user's guides and hardware support documents, latest software releases and archived software
- **General Technical Support** – Frequently Asked Questions (FAQ), technical support requests, online discussion groups, Microchip consultant program member listing
- **Business of Microchip** – Product selector and ordering guides, latest Microchip press releases, listing of seminars and events, listings of Microchip sales offices, distributors and factory representatives

CUSTOMER CHANGE NOTIFICATION SERVICE

Microchip's customer notification service helps keep customers current on Microchip products. Subscribers will receive e-mail notification whenever there are changes, updates, revisions or errata related to a specified product family or development tool of interest.

To register, access the Microchip web site at www.microchip.com. Under "Support", click on "Customer Change Notification" and follow the registration instructions.

CUSTOMER SUPPORT

Users of Microchip products can receive assistance through several channels:

- Distributor or Representative
- Local Sales Office
- Field Application Engineer (FAE)
- Technical Support

Customers should contact their distributor, representative or Field Application Engineer (FAE) for support. Local sales offices are also available to help customers. A listing of sales offices and locations is included in the back of this document.

Technical support is available through the web site at: <http://microchip.com/support>

Microchip Information

Trademarks

The “Microchip” name and logo, the “M” logo, and other names, logos, and brands are registered and unregistered trademarks of Microchip Technology Incorporated or its affiliates and/or subsidiaries in the United States and/or other countries (“Microchip Trademarks”). Information regarding Microchip Trademarks can be found at <https://www.microchip.com/en-us/about/legalinformation/microchip-trademarks>.

ISBN: 979-8-3371-0403-4

Legal Notice

This publication and the information herein may be used only with Microchip products, including to design, test, and integrate Microchip products with your application. Use of this information in any other manner violates these terms. Information regarding device applications is provided only for your convenience and may be superseded by updates. It is your responsibility to ensure that your application meets with your specifications. Contact your local Microchip sales office for additional support or, obtain additional support at www.microchip.com/en-us/support/design-help/client-support-services.

THIS INFORMATION IS PROVIDED BY MICROCHIP "AS IS". MICROCHIP MAKES NO REPRESENTATIONS OR WARRANTIES OF ANY KIND WHETHER EXPRESS OR IMPLIED, WRITTEN OR ORAL, STATUTORY OR OTHERWISE, RELATED TO THE INFORMATION INCLUDING BUT NOT LIMITED TO ANY IMPLIED WARRANTIES OF NON-INFRINGEMENT, MERCHANTABILITY, AND FITNESS FOR A PARTICULAR PURPOSE, OR WARRANTIES RELATED TO ITS CONDITION, QUALITY, OR PERFORMANCE.

IN NO EVENT WILL MICROCHIP BE LIABLE FOR ANY INDIRECT, SPECIAL, PUNITIVE, INCIDENTAL, OR CONSEQUENTIAL LOSS, DAMAGE, COST, OR EXPENSE OF ANY KIND WHATSOEVER RELATED TO THE INFORMATION OR ITS USE, HOWEVER CAUSED, EVEN IF MICROCHIP HAS BEEN ADVISED OF THE POSSIBILITY OR THE DAMAGES ARE FORESEEABLE. TO THE FULLEST EXTENT ALLOWED BY LAW, MICROCHIP'S TOTAL LIABILITY ON ALL CLAIMS IN ANY WAY RELATED TO THE INFORMATION OR ITS USE WILL NOT EXCEED THE AMOUNT OF FEES, IF ANY, THAT YOU HAVE PAID DIRECTLY TO MICROCHIP FOR THE INFORMATION.

Use of Microchip devices in life support and/or safety applications is entirely at the buyer's risk, and the buyer agrees to defend, indemnify and hold harmless Microchip from any and all damages, claims, suits, or expenses resulting from such use. No licenses are conveyed, implicitly or otherwise, under any Microchip intellectual property rights unless otherwise stated.

Microchip Devices Code Protection Feature

Note the following details of the code protection feature on Microchip products:

- Microchip products meet the specifications contained in their particular Microchip Data Sheet.
- Microchip believes that its family of products is secure when used in the intended manner, within operating specifications, and under normal conditions.
- Microchip values and aggressively protects its intellectual property rights. Attempts to breach the code protection features of Microchip product is strictly prohibited and may violate the Digital Millennium Copyright Act.
- Neither Microchip nor any other semiconductor manufacturer can guarantee the security of its code. Code protection does not mean that we are guaranteeing the product is “unbreakable”. Code protection is constantly evolving. Microchip is committed to continuously improving the code protection features of our products.