

SOTiny™ Low Voltage Dual SPDT Analog Switch 2:1 Mux/DeMux Bus Switch

Description

The DIODES PI5A3157 is a high-bandwidth, fast single-pole double-throw (SPDT) CMOS switch. It can be used as an analog switch or as a low-delay bus switch. Specified over a wide operating power supply voltage range, 1.65V to 5.5V, the PI5A3157 has a maximum ON resistance of 12Ω at 1.65V, 9Ω at 2.3V & 6Ω at 4.5V.

Break-before-make switching prevents both switches being enabled simultaneously. This eliminates signal disruption during switching.

The control input, S, tolerates input drive signals up to 5.5V, independent of supply voltage.

The PI5A3157 is an improved direct replacement for the NC-7SB3157.

Application(s)

- Cell Phones
- PDAs
- Portable Instrumentation
- Battery Powered Communications
- Computer Peripherals

Features

- CMOS Technology for Bus and Analog Applications
- Low On-Resistance: 8Ω at 3.0V
- Wide V_{DD} Range: 1.65V to 5.5V
- Rail-to-Rail Signal Range
- Control Input Overvoltage Tolerance: 5.5V min.
- Fast Transition Speed: 5.2ns max. at 5V
- High Off Isolation: 57dB at 10MHz
- 54dB (10MHz) Crosstalk Rejection Reduces Signal Distortion
- Break-Before-Make Switching
- High Bandwidth: 250 MHz
- Extended Industrial Temperature Range: -40°C to 85°C
- Improved Direct Replacement for NC7SB3157
- Totally Lead-Free & Fully RoHS Compliant (Notes 1 & 2)
- Halogen and Antimony Free. "Green" Device (Note 3)
- For automotive applications requiring specific change control (i.e. parts qualified to AEC-Q100/101/104/200, PPAP capable, and manufactured in IATF 16949 certified facilities), please [contact us](#) or your local Diodes representative. <https://www.diodes.com/quality/product-definitions/>
- Packaging (Pb-free & Green available):
 - 6-pin SC70 (C)

Notes:

1. No purposely added lead. Fully EU Directive 2002/95/EC (RoHS), 2011/65/EU (RoHS 2) & 2015/863/EU (RoHS 3) compliant.
2. See <https://www.diodes.com/quality/lead-free/> for more information about Diodes Incorporated's definitions of Halogen- and Antimony-free, "Green" and Lead-free.
3. Halogen- and Antimony-free "Green" products are defined as those which contain <900ppm bromine, <900ppm chlorine (<1500ppm total Br + Cl) and <1000ppm antimony compounds.

Pin Configuration/Connection Diagram

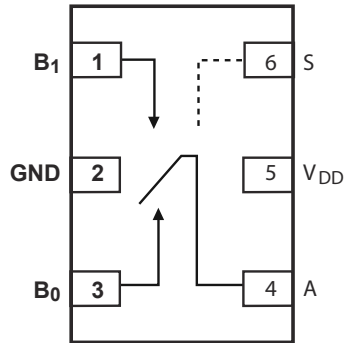

Pin Description

Pin Number	Pin Name	Description
1	B1	Data port
2	GND	Ground
3	B ₀	Data port (Normally Closed)
4	A	Common Output/Data port
5	V _{DD}	Positive Power Supply
6	S	Logic Control

Logic Function Table

Logic Input(s)	Function
0	B ₀ Connection to A
1	B ₁ Connected to A

Absolute Maximum Ratings⁽¹⁾

Supply Voltage V_{DD}	-0.5V to +7V
DC Switch Voltage (V_S) ⁽²⁾	-0.5V to $V_{DD} + 0.5V$
DC Input Voltage (V_{IN}) ⁽²⁾	-0.5V to +7.0V
DC Output Current (I_{OUT})	128mA
DC V_{DD} or Ground Current (I_{CC}/I_{GND})	$\pm 100mA$
Storage Temperature Range (T_{STG})	-65°C to +150°C
Junction Temperature under Bias (T_J)	125°C
Power Dissipation (P_D) @ +85°C	180mW

Recommended Operating Conditions⁽³⁾

Supply Voltage Operating (V_{DD})	1.65V to 5.5V
Control Input Voltage (V_{IN})	0V to V_{DD}
Switch Input Voltage (V_{IN})	0V to V_{DD}
Output Voltage (V_{OUT})	0V to V_{DD}
Operating Temperature (T_A)	-40°C to +85°C
Input Rise and Fall Time (t_{Rf})	
Control Input $V_{DD} = 2.3V - 3.6V$	0ns/V to 10ns/V
Control Input $V_{DD} = 4.5V - 5.5V$	0ns/V to 5ns/V
Thermal Resistance (θ_{JA})	350°C/W

Notes:

1. Absolute Maximum Ratings” may cause permanent damage to the device. This is a stress only rating and operation of the device at these or any other conditions beyond those indicated in the operational sections of this specification is not implied.
2. The input and output negative voltage ratings may be exceeded if the input and output diode current ratings are observed.
3. Control input must be held HIGH or LOW; it must not float.

DC Electrical Characteristics

Over the Operating Temperature Range, $T_A = -40^\circ C$ to $85^\circ C$

Parameters	Description	Test Conditions	Supply Voltage	Temp	Min.	Typ.	Max.	Units	
V_{IAR}	Analog Input Signal Range		V_{DD}	$T_A = 25^\circ C$ & -40°C to 85°C	0		V_{DD}	V	
R_{ON}	On-Resistance ⁽¹⁾	$I_O = 30mA, V_{IN} = 0V$	4.5V	$T_A = 25^\circ C$		4	6	Ω	
		$I_O = -30mA, V_{IN} = 2.4V$				5	8		
		$I_O = -30mA, V_{IN} = 4.5V$				8	13		
		$I_O = 30mA, V_{IN} = 0V$	4.5V	$T_A = -40^\circ C$ to 85°C			6		
		$I_O = -30mA, V_{IN} = 2.4V$					8		
		$I_O = -30mA, V_{IN} = 4.5V$					13		
		$I_O = 24mA, V_{IN} = 0V$	3.0V	$T_A = 25^\circ C$		5	8		
		$I_O = -24mA, V_{IN} = 3.0V$				12	19		
		$I_O = 24mA, V_{IN} = 0V$	3.0V	$T_A = -40^\circ C$ to 85°C			8		
		$I_O = -24mA, V_{IN} = 3.0V$					19		
		$I_O = 24mA, V_{IN} = 0V$	2.3V	$T_A = 25^\circ C$		6	9		
		$I_O = -24mA, V_{IN} = 2.3V$				16	24		
		$I_O = 24mA, V_{IN} = 0V$	2.3V	$T_A = -40^\circ C$ to 85°C			9		
		$I_O = -24mA, V_{IN} = 2.3V$					24		
		$I_O = 24mA, V_{IN} = 0V$	1.65V	$T_A = 25^\circ C$		8	12		
		$I_O = -24mA, V_{IN} = 1.65V$				27	39		
$I_O = 24mA, V_{IN} = 0V$	1.65V	$T_A = -40^\circ C$ to 85°C			12				
$I_O = -24mA, V_{IN} = 1.65V$					39				

Parameters	Description	Test Conditions	Supply Voltage	Temp	Min.	Typ.	Max.	Units
ΔR_{ON}	On-Resistance Match Between Channels ^(1, 2, 3)	$I_A = -30\text{mA}, V_{BN} = 3.15\text{V}$	4.5V	$T_A = 25^\circ\text{C}$		0.15		
		$I_A = -24\text{mA}, V_{BN} = 2.1\text{V}$	3.0V			0.2		
		$I_A = -8\text{mA}, V_{BN} = 1.6\text{V}$	2.3V			0.3		
		$I_A = -4\text{mA}, V_{BN} = 1.15\text{V}$	1.65V			0.3		
R_{ONF}	On-Resistance Flatness ^(1, 2, 4)	$I_A = -30\text{mA}, 0 \leq V_{BN} \leq V_{DD}$	5.0V	$T_A = 25^\circ\text{C}$		6		Ω
		$I_A = -24\text{mA}, 0 \leq V_{BN} \leq V_{DD}$	3.3V			12		
		$I_A = -8\text{mA}, 0 \leq V_{BN} \leq V_{DD}$	2.5V			22		
		$I_A = -4\text{mA}, 0 \leq V_{BN} \leq V_{DD}$	1.8V			90		
V_{IH}	Input High Voltage	Logic High Level	$V_{DD} = 1.65\text{V to } 1.95\text{V}$ $V_{DD} = 2.3\text{V to } 5.5\text{V}$	$T_A = 25^\circ\text{C}$ & $-40^\circ\text{C to } 85^\circ\text{C}$	0.75 V_{DD} 0.7 V_{DD}			V
V_{IL}	Input Low Voltage	Logic Low Level	$V_{DD} = 1.65\text{V to } 1.95\text{V}$ $V_{DD} = 2.3\text{V to } 5.5\text{V}$				0.25 V_{DD} 0.25 V_{DD}	
	Input Leakage Current	$0 \leq V_{IN} \leq 5.5\text{V}$	$V_{DD} \leq 0\text{V} \leq 5.5\text{V}$	$T_A = 25^\circ\text{C}$ $T_A = -40^\circ\text{C to } 85^\circ\text{C}$			± 0.1 ± 1.0	μA
I_{OFF}	OFF State Leakage Current	$0 \leq V_{IN} \leq 5.5\text{V}$	$V_{DD} \leq 1.65\text{V} \leq 5.5\text{V}$	$T_A = 25^\circ\text{C}$ $T_A = -40^\circ\text{C to } 85^\circ\text{C}$			± 0.1 ± 10	
I_{CC}	Quiescent Supply Current	All Channels ON or OFF, $V_{IN} = V_{DD}$ or GND, $I_{OUT} = 0$	$V_{DD} = 5.5\text{V}$	$T_A = 25^\circ\text{C}$ $T_A = -40^\circ\text{C to } 85^\circ\text{C}$			1 10	

Notes:

1. Measured by voltage drop between A and B pins at the indicated current through the device. On-Resistance is determined by the lower of the voltages on two ports (A or B).
2. Parameter is characterized but not tested in production.
3. $\Delta R_{ON} = R_{ON \text{ max}} - R_{ON \text{ min}}$. measured at identical V_{DD} , temperature and voltage levels.
4. Flatness is defined as difference between maximum and minimum value of On-Resistance over the specified range of conditions.
5. Guaranteed by design.

Capacitance⁽¹⁾

Parameters	Description	Test Conditions	Supply Voltage	Temp	Min.	Typ.	Max.	Units	
C_{IN}	Control Input		$V_{DD} = 5.0\text{V}$	$T_A = 25^\circ\text{C}$		2.3		pF	
C_{IO-B}	For B Port, Switch OFF	$f = 1 \text{ MHz}^{(1)}$					6.5		
C_{IOA-ON}	For A Port, Switch ON						18.5		

Note:

1. $T_A = 25^\circ\text{C}$, $f = 1\text{MHz}$. Capacitance is characterized but not tested in production.

Switch and AC Characteristics

Parameters	Description	Test Conditions	Supply Voltage	Temp	Min.	Typ.	Max.	Units
t _{PLH} t _{PHL}	Propagation Delay: A to Bn	See test circuit diagram 1 and 2 V _I Open ⁽²⁾	V _{DD} = 2.3V to 2.7V	T _A = 25°C & -40°C to 85°C		1.2		
			V _{DD} = 3.0V to 3.6V			0.8		
			V _{DD} = 4.5V to 5.5V			0.3		
t _{PZL} t _{PZH}	Output Enable Turn ON Time: A to Bn	See test circuit diagram 1 and 2 V _I = 2 V _{DD} for t _{PZL} , V _I = 0V for t _{PZH}	V _{DD} = 1.65V to 1.95V	T _A = 25°C		7	23	
			V _{DD} = 2.3V to 2.7V			3.5	13	
			V _{DD} = 3.0V to 3.6V			2.5	6.9	
			V _{DD} = 4.5V to 5.5V			1.7	5.2	
t _{PZL} t _{PZH}	Output Enable Turn ON Time: A to Bn	See test circuit diagram 1 and 2 V _I = 2 V _{DD} for t _{PZL} , V _I = 0V for t _{PZH}	V _{DD} = 2.5V	T _A = 25°C & -40°C to 85°C			24	
			V _{DD} = 3.3V				14	
			V _{DD} = 3.0V to 3.6V				7.6	
			V _{DD} = 4.5V to 5.5V				5.7	
t _{PLZ} t _{PHZ}	Output Disable-Turn OFF Time: A to Bn	See test circuit diagram 1 and 2 V _I = 2 V _{DD} for t _{PLZ} , V _I = 0V for t _{PHZ}	V _{DD} = 1.65V to 1.95V	T _A = 25°C		3	12.5	ns
			V _{DD} = 2.3V to 2.7V			2	7	
			V _{DD} = 3.0V to 3.6V			1.5	5	
			V _{DD} = 4.5V to 5.5V			0.8	3.5	
t _{PLZ} t _{PHZ}	Output Disable-Turn OFF Time: A to Bn	See test circuit diagram 1 and 2 V _I = 2 V _{DD} for t _{PLZ} , V _I = 0V for t _{PHZ}	V _{DD} = 2.5V	T _A = 25°C & -40°C to 85°C			13	
			V _{DD} = 3.3V				7.5	
			V _{DD} = 3.0V to 3.6V				5.3	
			V _{DD} = 4.5V to 5.5V				3.8	
t _{BM}	Break Before Make Time	See test circuit diagram 9. ⁽¹⁾	V _{DD} = 2.5V	T _A = 25°C & -40°C to 85°C		0.5		
			V _{DD} = 3.3V			0.5		
			V _{DD} = 3.0V to 3.6V			0.5		
			V _{DD} = 4.5V to 5.5V			0.5		
Q	Charge Injection	C _L = 0.1nF, V _{GEN} = 0V, R _{GEN} = 0Ω, See test circuit 4	V _{DD} = 5.0V	T _A = 25°C		7		pC
			V _{DD} = 3.3V			3		
O _{IRR}	Off Isolation	R _L = 50Ω, V _{GEN} = 0V, R _{GEN} = 0Ω, See test circuit 5 ⁽³⁾	V _{DD} = 1.65V to 5.5V	T _A = 25°C		-57		dB
X _{TALK}	Crosstalk Isolation	See test circuit 6	V _{DD} = 1.65V to 5.5V	T _A = 25°C		-54		
f _{3dB}	-3dB Bandwidth	See test circuit 9	V _{DD} = 1.65V to 5.5V	T _A = 25°C		250		MHz

Notes:

- Guaranteed by design.
- Guaranteed by design but not production tested. The device contributes no other propagation delay other than the RC delay of the switch On-Resistance and the 50pF load capacitance, when driven by an ideal voltage source with zero output impedance.
- Off Isolation = 20 Log₁₀ [V_A / V_{Bn}] and is measured in dB.

Test Circuits and Timing Diagrams

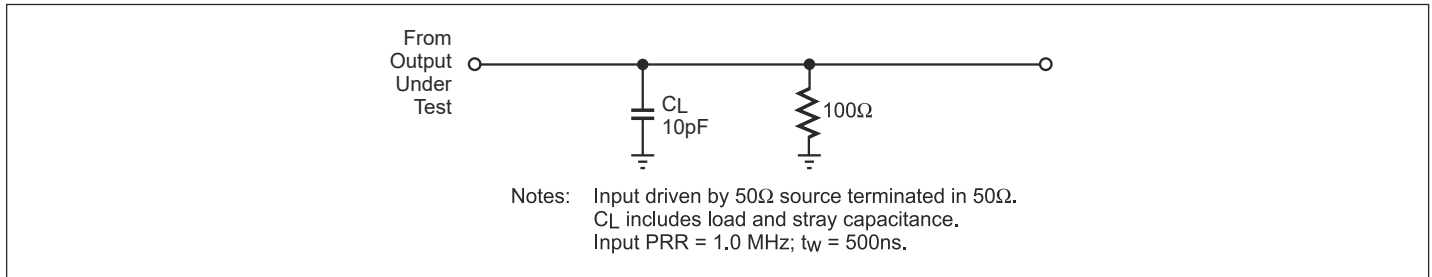

Figure 1. AC Test Circuit

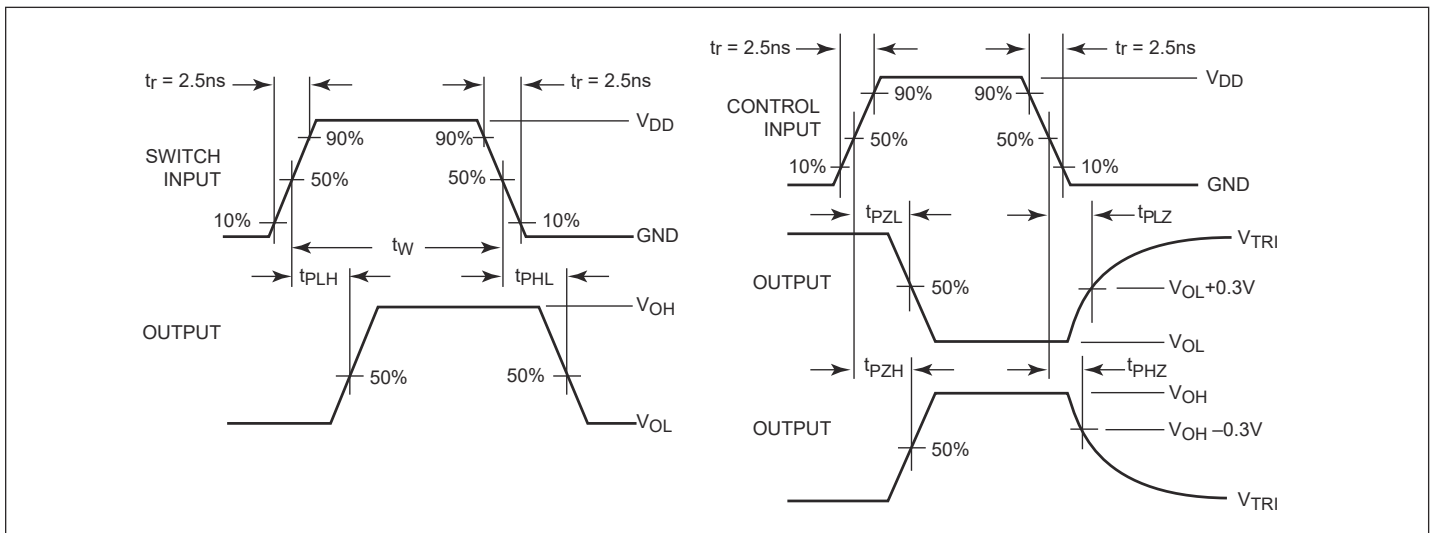

Figure 2. AC Waveforms

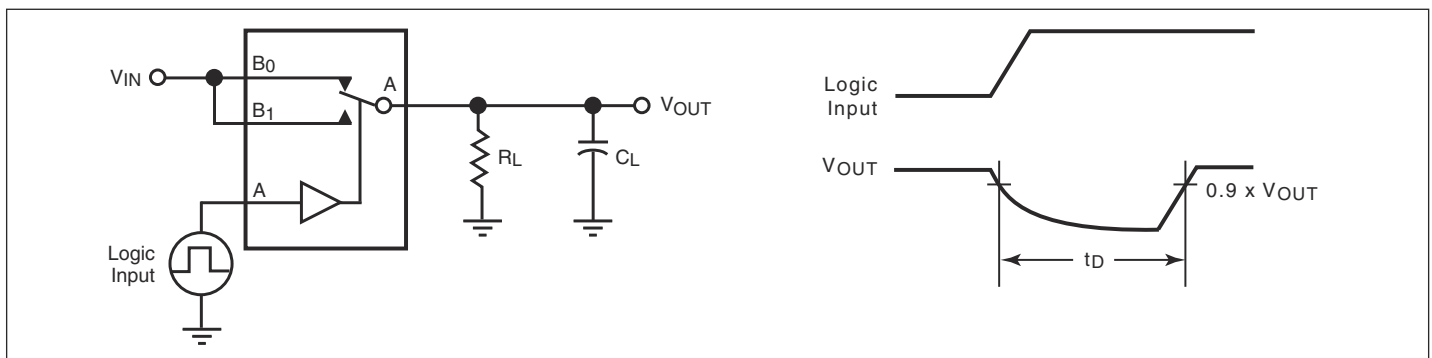

Figure 3. Break Before Make Interval Timing

PI5A3157

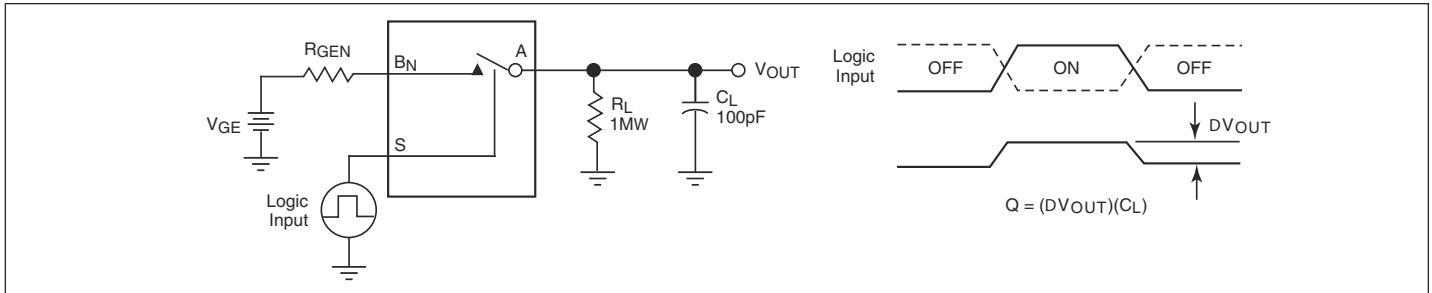

Figure 4. Charge Injection Test

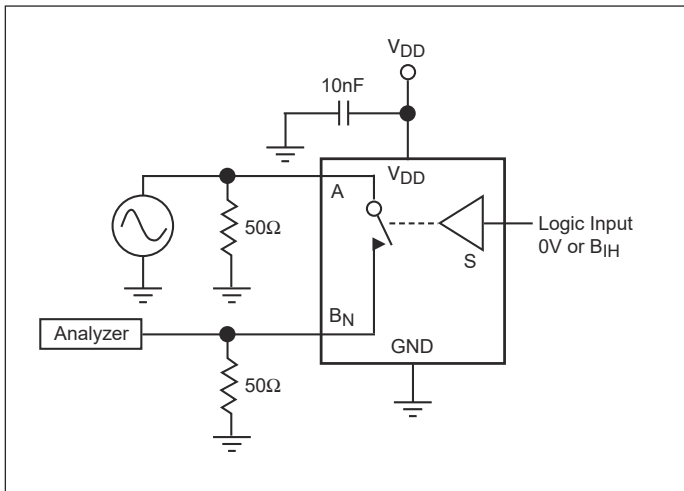

Figure 5. Off Isolation

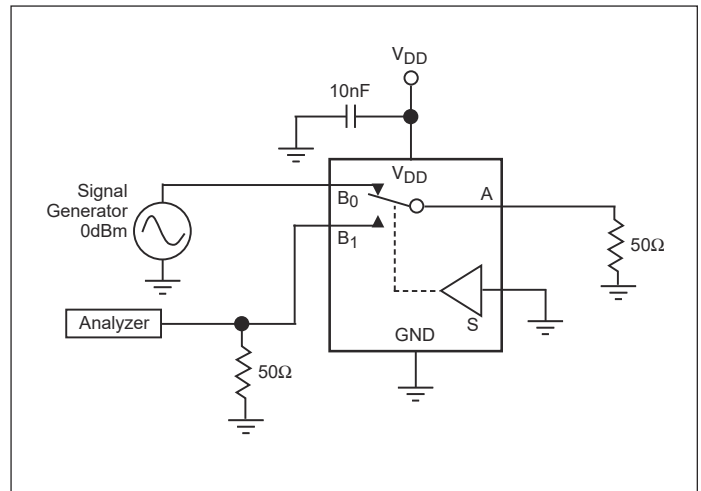

Figure 6. Crosstalk

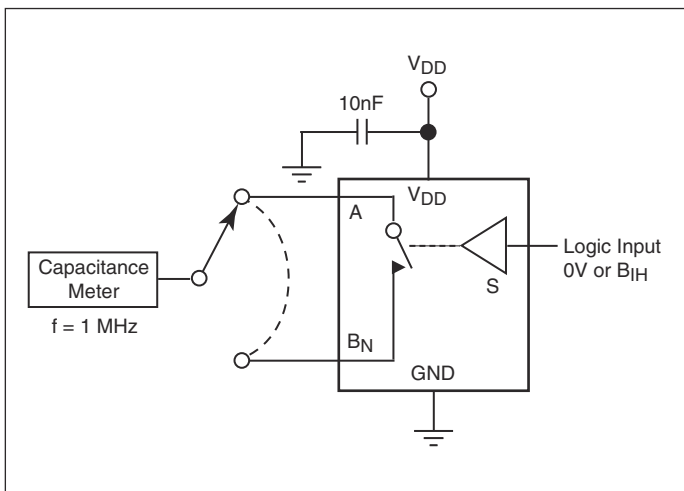

Figure 7. Channel Off Capacitance

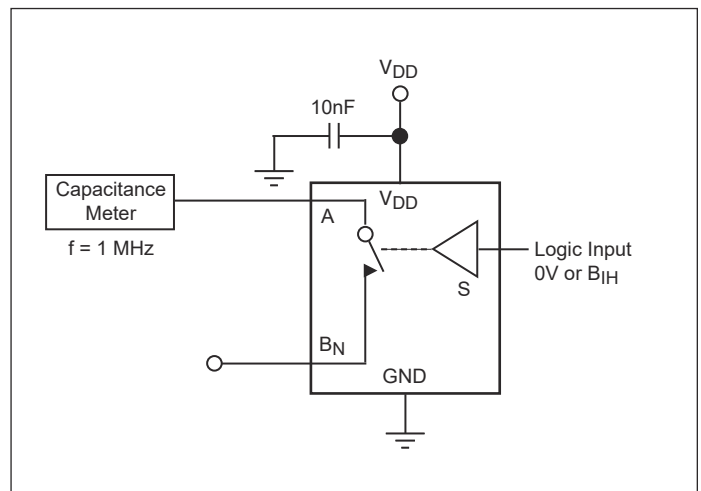

Figure 8. Channel On Capacitance

PI5A3157

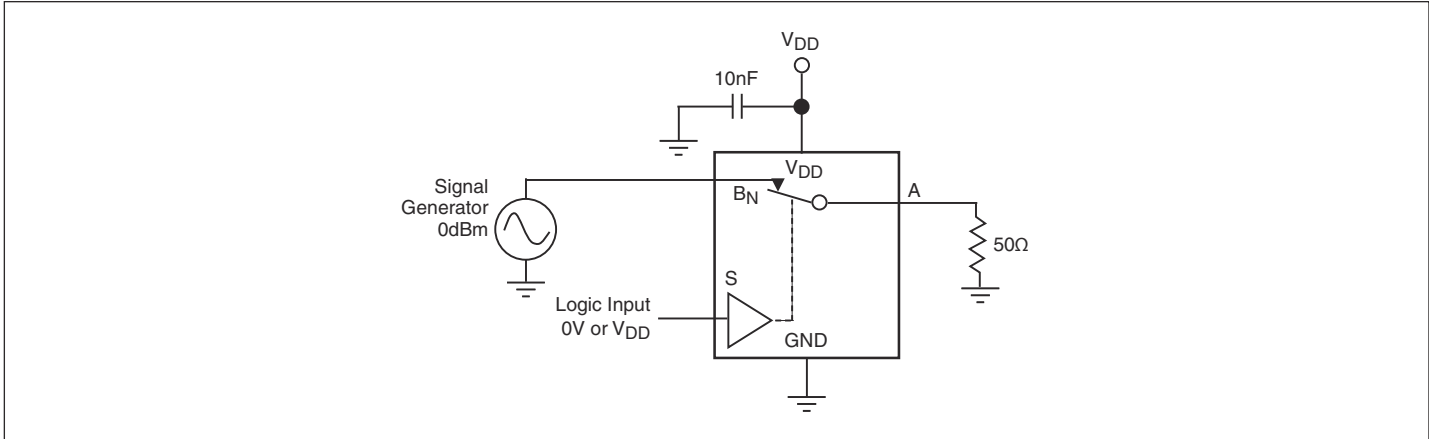
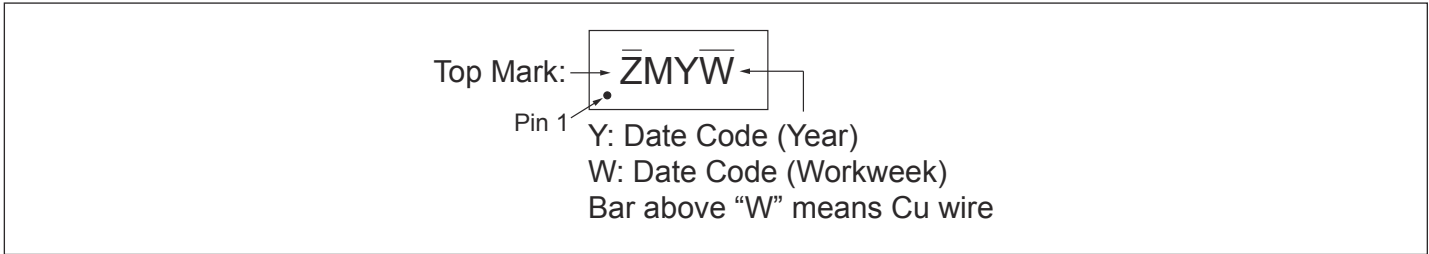

Figure 9. Bandwidth

Part Marking



Packaging Mechanical

6-SC70 (C)

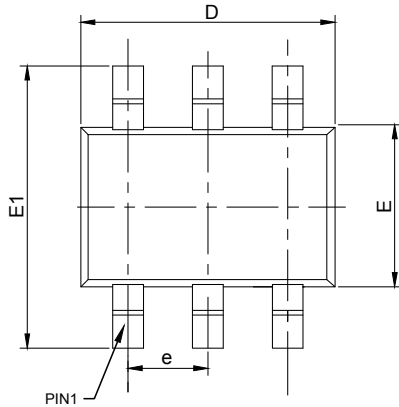

TOP VIEW

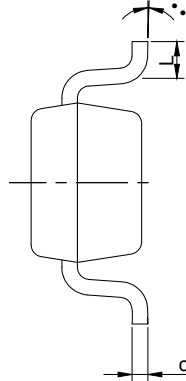

BOTTOM VIEW

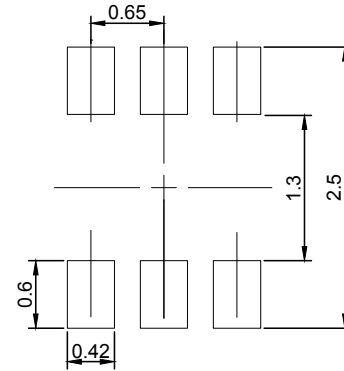

RECOMMENDED LAND PATTERN (unit:mm)

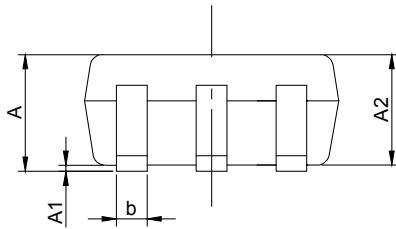

SIDE VIEW

PKG. DIMENSIONS(MM)		
SYMBOL	Min	Max
A	-	1.10
A1	0.00	0.10
A2	0.70	1.00
b	0.15	0.40
c	0.08	0.22
D	1.80	2.20
E	1.10	1.40
E1	1.80	2.45
e	0.65 BSC	
L	0.26	0.46
θ	0°	8°

Notes:

1. Comply with MO-203C/AB, except b Max, D Min and D Max.
2. PACKAGE OUTLINE DIMENSIONS DO NOT INCLUDE MOLD FLASH AND METAL BURR
3. LAND PATTERN REFERENCE DIODES SOT363 PACKAGE INFORMATION.



DATE: 12/16/21

DESCRIPTION: 6-Pin, SOT363 (SC70)

PACKAGE CODE: C (C6)

DOCUMENT CONTROL#: PD-1902

REVISION: D

21-1534

For latest package info.

please check: <http://www.diodes.com/design/support/packaging/pericom-packaging/packaging-mechanicals-and-thermal-characteristics/>

Ordering Information

Ordering Code	Packaging Code	Package Description	Top Mark
PI5A3157CEX	C	6-pin, SOT363 (SC70)	ZM

Notes:

1. No purposely added lead. Fully EU Directive 2002/95/EC (RoHS), 2011/65/EU (RoHS 2) & 2015/863/EU (RoHS 3) compliant.
2. See <https://www.diodes.com/quality/lead-free/> for more information about Diodes Incorporated's definitions of Halogen- and Antimony-free, "Green" and Lead-free.
3. Halogen- and Antimony-free "Green" products are defined as those which contain <900ppm bromine, <900ppm chlorine (<1500ppm total Br + Cl) and <1000ppm antimony compounds.
4. E = Pb-free and Green
5. X suffix = Tape/Reel

IMPORTANT NOTICE

1. DIODES INCORPORATED (Diodes) AND ITS SUBSIDIARIES MAKE NO WARRANTY OF ANY KIND, EXPRESS OR IMPLIED, WITH REGARDS TO ANY INFORMATION CONTAINED IN THIS DOCUMENT, INCLUDING, BUT NOT LIMITED TO, THE IMPLIED WARRANTIES OF MERCHANTABILITY, FITNESS FOR A PARTICULAR PURPOSE OR NON-INFRINGEMENT OF THIRD PARTY INTELLECTUAL PROPERTY RIGHTS (AND THEIR EQUIVALENTS UNDER THE LAWS OF ANY JURISDICTION).

2. The Information contained herein is for informational purpose only and is provided only to illustrate the operation of Diodes' products described herein and application examples. Diodes does not assume any liability arising out of the application or use of this document or any product described herein. This document is intended for skilled and technically trained engineering customers and users who design with Diodes' products. Diodes' products may be used to facilitate safety-related applications; however, in all instances customers and users are responsible for (a) selecting the appropriate Diodes products for their applications, (b) evaluating the suitability of Diodes' products for their intended applications, (c) ensuring their applications, which incorporate Diodes' products, comply the applicable legal and regulatory requirements as well as safety and functional-safety related standards, and (d) ensuring they design with appropriate safeguards (including testing, validation, quality control techniques, redundancy, malfunction prevention, and appropriate treatment for aging degradation) to minimize the risks associated with their applications.

3. Diodes assumes no liability for any application-related information, support, assistance or feedback that may be provided by Diodes from time to time. Any customer or user of this document or products described herein will assume all risks and liabilities associated with such use, and will hold Diodes and all companies whose products are represented herein or on Diodes' websites, harmless against all damages and liabilities.

4. Products described herein may be covered by one or more United States, international or foreign patents and pending patent applications. Product names and markings noted herein may also be covered by one or more United States, international or foreign trademarks and trademark applications. Diodes does not convey any license under any of its intellectual property rights or the rights of any third parties (including third parties whose products and services may be described in this document or on Diodes' website) under this document.

5. Diodes' products are provided subject to Diodes' Standard Terms and Conditions of Sale (<https://www.diodes.com/about/company/terms-and-conditions/terms-and-conditions-of-sales/>) or other applicable terms. This document does not alter or expand the applicable warranties provided by Diodes. Diodes does not warrant or accept any liability whatsoever in respect of any products purchased through unauthorized sales channel.

6. Diodes' products and technology may not be used for or incorporated into any products or systems whose manufacture, use or sale is prohibited under any applicable laws and regulations. Should customers or users use Diodes' products in contravention of any applicable laws or regulations, or for any unintended or unauthorized application, customers and users will (a) be solely responsible for any damages, losses or penalties arising in connection therewith or as a result thereof, and (b) indemnify and hold Diodes and its representatives and agents harmless against any and all claims, damages, expenses, and attorney fees arising out of, directly or indirectly, any claim relating to any noncompliance with the applicable laws and regulations, as well as any unintended or unauthorized application.

7. While efforts have been made to ensure the information contained in this document is accurate, complete and current, it may contain technical inaccuracies, omissions and typographical errors. Diodes does not warrant that information contained in this document is error-free and Diodes is under no obligation to update or otherwise correct this information. Notwithstanding the foregoing, Diodes reserves the right to make modifications, enhancements, improvements, corrections or other changes without further notice to this document and any product described herein. This document is written in English but may be translated into multiple languages for reference. Only the English version of this document is the final and determinative format released by Diodes.

8. Any unauthorized copying, modification, distribution, transmission, display or other use of this document (or any portion hereof) is prohibited. Diodes assumes no responsibility for any losses incurred by the customers or users or any third parties arising from any such unauthorized use.

9. This Notice may be periodically updated with the most recent version available at <https://www.diodes.com/about/company/terms-and-conditions/important-notice>

The Diodes logo is a registered trademark of Diodes Incorporated in the United States and other countries.

All other trademarks are the property of their respective owners.

© 2023 Diodes Incorporated. All Rights Reserved.

www.diodes.com