

## RS31330 RS31331 RS31332 2.97V-16V 7A eFuse Protection Switches With Accuracy Current Monitor and Transient Overcurrent Blanking

### Features

- Wide input voltage range: 2.97V to 16V
  - Integrated 5.8mΩ Pass MOSFET
  - Fast over-voltage protection
    - OVCSEL: Overvoltage clamp with pin selectable threshold (3.89V, 5.76V, 13.88V)
    - OVLO: Adjustable overvoltage lockout
  - Overcurrent protection with load current monitor output (ILM)
    - Active current limit or circuit-breaker
    - Adjustable 0.87A to 7.7A current limit
    - Adjustable transient blanking timer (ITIMER) to allow high transient current
  - Fast-trip response for short-circuit protection
  - Adjustable output slew rate (dVdt)
  - Enable with adjustable input UVLO threshold
  - Built-on over temperature protection
  - Fault indication or power good indication
  - RoHS compliant and Green
- PCI and PCIe cards
  - Appliances and power tools
  - Smartphones and tablets
  - Industrial system

### Description

The RS31330/331/332 devices are active circuit protection devices with an integrated MOSFET used to limit current and voltage to safe levels during fault conditions.

The current limit level can be set with a resistor between ILM and ground.

The device has over voltage protection feature which either limits the output voltage to a fixed level or cuts off the output when input over voltage fault occurs.

To limit the inrush current during device turn-on, the rising slew rate of output voltage can be set by a capacitor between dVdt and ground.

The device also offers EN on/off control and input UVLO features.

The device is available in QFN-10 pins, 2x2 mm package.

### Applications

- Server, PC mother board

### Typical Application Circuit

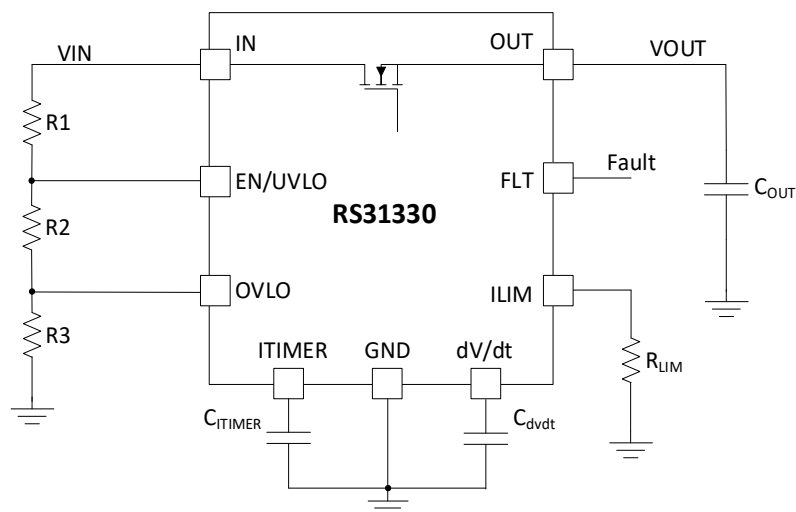

Package Reference

RS31330, Top View (QFN-10)

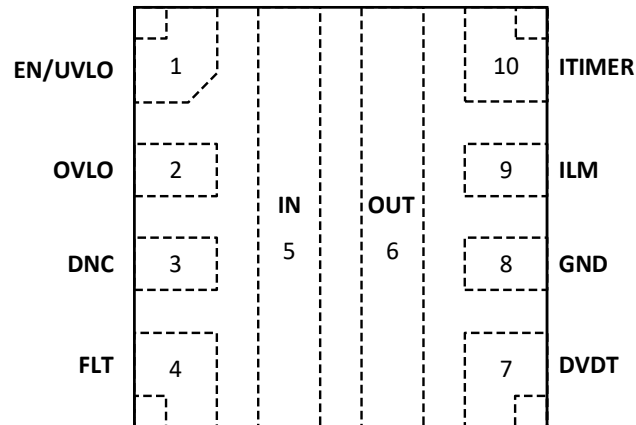

RS31331, Top View (QFN-10)

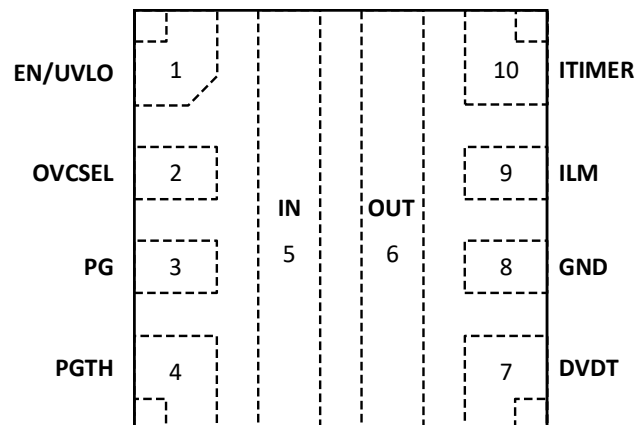

RS31332, Top View (QFN-10)

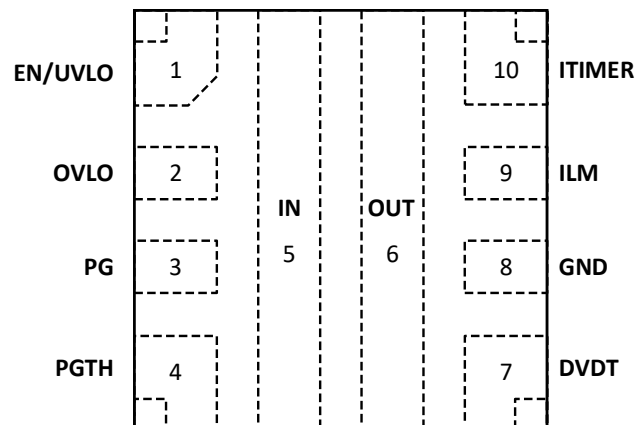

## Device Comparison Table

Part Number	Input OV	OC response	PG and PGTH	FLT	OT Protection
RS31330A	Adjustable OVLO	Active Current Limit	N	Y	Latch
RS31330B	Adjustable OVLO	Active Current Limit	N	Y	Auto retry
RS31331A	Pin Selectable OVC	Active Current Limit	Y	N	Latch
RS31331B	Pin Selectable OVC	Active Current Limit	Y	N	Auto retry
RS31332A	Adjustable OVLO	Circuit Breaker	Y	N	Latch
RS31332B	Adjustable OVLO	Circuit Breaker	Y	N	Auto retry

## Order Information

Part Number	Package	Size	MSL	Shipping Method	Package Marking
RS31330AR	QFN-10	2x2 mm	Level-2	3000u Tape & Reel	330A
RS31330BR	QFN-10	2x2 mm	Level-2	3000u Tape & Reel	330B
RS31331AR	QFN-10	2x2 mm	Level-2	3000u Tape & Reel	331A
RS31331BR	QFN-10	2x2 mm	Level-2	3000u Tape & Reel	331B
RS31332AR	QFN-10	2x2 mm	Level-2	3000u Tape & Reel	332A
RS31332BR	QFN-10	2x2 mm	Level-2	3000u Tape & Reel	332B

## Top Marking

RYWS
PPPP
● LLL

### Line 1

- R: Prefix of Reed Semiconductor (R is replaced by E for engineering lot)
- Y: Year code
- W: Week code
- S: Assembly site code

### Line 2

- PPPP: Truncated part number. Example: 332A represents the full part number RS31332A

### Line 3

- LLL: Lot code

**Pin Description**

No.	NAME	TYPE	Description
1	EN/UVLO	I	Active high enable. Pull high to enable the device, and pull low to disable the device. Connect the pin to a resistor divider from Vin to GND to set input UVLO threshold. Do not leave the pin floating.
2	OVLO	I	<b>RS31330 and RS31332:</b> A resistor divider from VIN to GND can be used to set input overvoltage threshold. This pin can also be used as active low enable for the device. Do not leave floating.
	OVCSEL	I	<b>RS31331:</b> Overvoltage clamp threshold select pin.
3	PG	O	<b>RS31331 and RS31332:</b> Open drain pin. Assert high when the internal power switch is fully turned on and PGTH input exceeds a certain threshold.
	DNC	N	<b>RS31330:</b> No internal connection. Leave floating
4	FLT	O	<b>RS31330:</b> Open drain pin. Pulled low when a fault is detected.
	PGTH	I	<b>RS31331 and RS31332:</b> Power good threshold
5	IN	I	Input supply voltage
6	OUT	O	Output of the device
7	dVdt	O	Connect a capacitor from this pin to GND to set output voltage rising slew rate during turn-on
8	GND	G	The GND pad is used as device ground. Connect to system ground.
9	ILM	O	Dual function pin to limit and monitor the output current. An external resistor from the pin to GND sets the output current limit. The pin voltage can be used to monitor the output current. Do not leave floating.
10	ITIMER	O	A capacitor from this pin to GND sets the overcurrent blanking time during which the output current can temporarily exceed the set current limit, but lower than fast-trip threshold. Leave the pin open for the fastest response to overcurrent events.

### PACKAGE DIMENSION

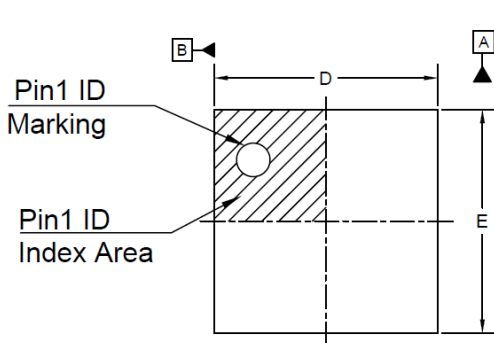

TOP VIEW

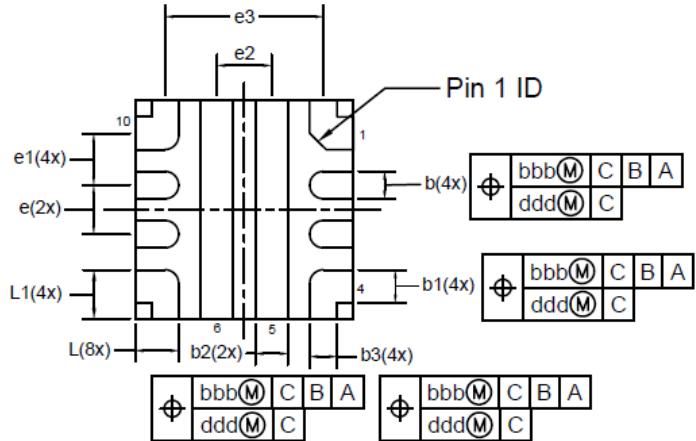

BOTTOM VIEW

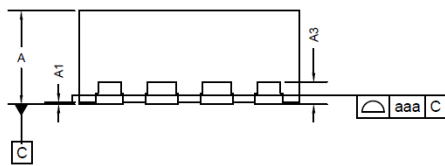

SIDE VIEW

REF	MIN	NOM	MAX
A	0.750	0.850	0.950
A1	0.000		0.050
A3	0.203 REF		
D	1.900	2.000	2.100
E	1.900	2.000	2.100
b	0.200	0.250	0.300
b1	0.250	0.300	0.350
b2	0.250	0.300	0.350
b3	0.200	0.250	0.300
e	0.450 BSC		
e1	0.475 BSC		
e2	0.500 REF		
e3	1.450 REF		
L	0.300	0.400	0.500
L1	0.400	0.450	0.500
Tol of Form & Position			
aaa	0.08		
bbb	0.1		
ddd	0.05		

NOTE:

1. ALL DIMENSIONS ARE IN MILLIMETERS.
2. DIMENSION b APPLIES TO METALLIZED TERMINAL AND IS MEASURED BETWEEN 0.15mm AND 0.30mm FROM THE TERMINAL TIP. IF THE TERMINAL HAS THE OPTIONAL RADIUS ON THE OTHER END OF THE TERMINAL, THE DEMENSION b SHOULD NOT BE MEASURED IN THAT RADIUS AREA.
3. BILATERAL COPLANARITY ZONE APPLIES TO THE EXPOSED HEAT SINK SLUG AS WELL AS THE TERMINALS.

**RECOMMENDED LAND PATTERN**

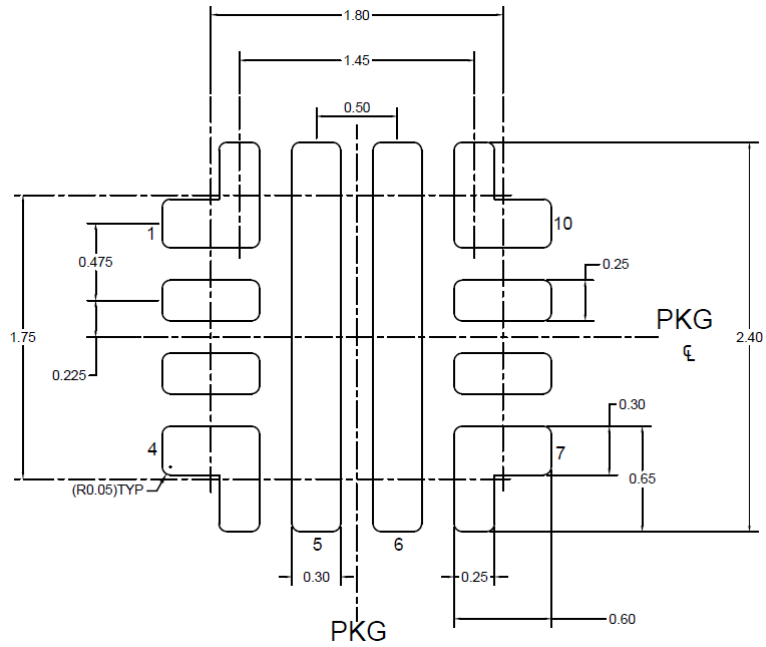

Note: All the data is nominal

**TAPE AND REEL INFORMATION**

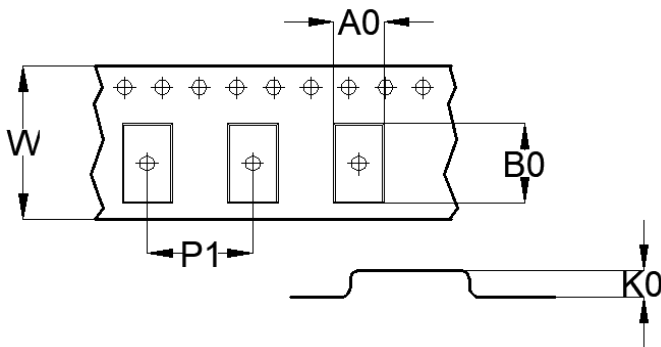
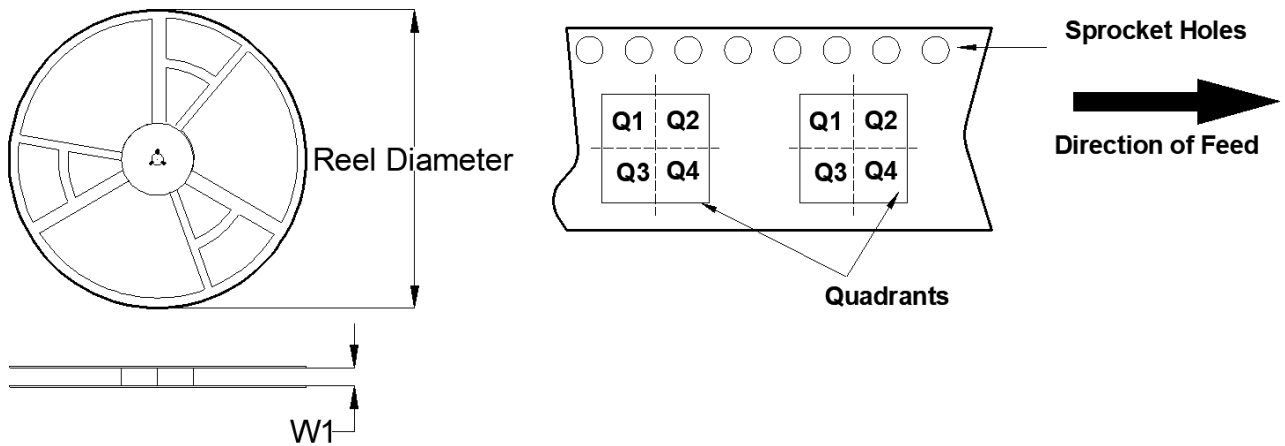

A0	Pocket width
B0	Pocket length
K0	Pocket thickness
W1	Reel Width
W	Inner width of the carrier tape
P1	Pitch between pocket centers

PKG type (mm)	Reel Diameter (mm)	Reel Width W1(mm)	A0(mm)	B0(mm)	K0(mm)	P1(mm)	W(mm)	Quad
2x2	178	9.5	2.2	2.2	1.1	4.0	8.0	Q2

Note: All the data is nominal

**PIZZA BOX DIMENSION**

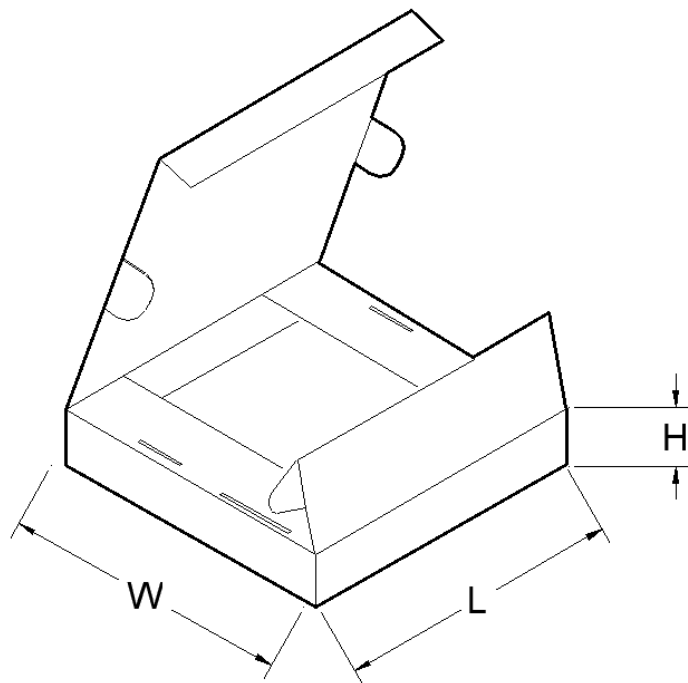

PKG type (mm)	Units/box	Length(mm)	Width(mm)	Height(mm)
2x2	3000	205	200	25

Note: All the data is nominal