

Description

The ZXCT180 is a uni-directional current shunt monitor which is designed to be a cost-effective solution to deal with 26V common-mode in a smaller supply voltage range 2.7V to 5.5V powering the device.

The ZXCT180 supports the small-signal bandwidths as high as 400kHz at 20V/V gain and fast large-signal slew rates of 2V/μs. This ability can be used to detect rapid changes in the sensed current and fast response to the output so that these features make the ZXCT180 a good choice for applications such as low-side motor control and the system fault current detection.

OUT pin is a voltage proportional to the load current. Based on OUT pin configurations, ZXCT180 has Pinout A and B as a flexibility for users to choose a proper one for PCB layout. In addition, this device has four fixed voltage gain options in 20V/V, 50V/V, 100V/V, and 200V/V. It can measure voltage across shunts at common-mode voltages from -0.3V to 26V, independent of supply voltage with a maximum supply current of 370μA. All versions are AEC-Q100 grade 1 temperature range, -40°C to +125°C, and are offered in the SOT25 package.

Features

- Supply Voltage Range: 2.7V to 5.5V
- Wide Common-Mode Range: -0.3V to 26V
- Gain Error: (Maximum over Temperature): ±1%
- Choice of Gains:
 - Pinout A1 and B1: 20V/V
 - Pinout A2 and B2: 50V/V
 - Pinout A3 and B3: 100V/V
 - Pinout A4 and B4: 200V/V
- Low Offset Voltage: Typical ±100μV and 1-μV/°C Drift
- Rail-to-Rail Output Capability
- Low Quiescent Current: 370μA (max)
- Package: 5-Pin SOT25
- ESD Protection JESD 22, 5000V HBM (A114)
- **Totally Lead-Free & Fully RoHS Compliant (Notes 1 & 2)**
- **Halogen and Antimony Free. "Green" Device (Note 3)**
- **For automotive applications requiring specific change control (i.e. parts qualified to AEC-Q100/101/104/200, PPAP capable, and manufactured in IATF 16949 certified facilities), please [contact us](mailto:contact@diodes.com) or your local Diodes representative.**
<https://www.diodes.com/quality/product-definitions/>

- Notes:
1. No purposely added lead. Fully EU Directive 2002/95/EC (RoHS), 2011/65/EU (RoHS 2) & 2015/863/EU (RoHS 3) compliant.
 2. See <https://www.diodes.com/quality/lead-free/> for more information about Diodes Incorporated's definitions of Halogen- and Antimony-free, "Green" and Lead-free.
 3. Halogen- and Antimony-free "Green" products are defined as those which contain <900ppm bromine, <900ppm chlorine (<1500ppm total Br + Cl) and <1000ppm antimony compounds.

Pin Assignments

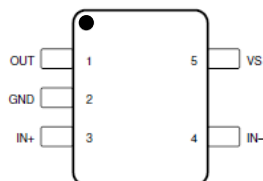

SOT25
(OUT 1, Version A)

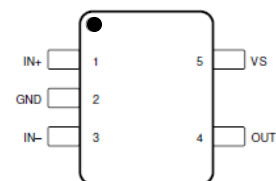

SOT25
(OUT 4, Version B)

Applications

- Motor controls
- Lighting controls
- Power management
- Fault current detection
- Current sensing (high-side/low-side)
- Solar inverters

Typical Applications Circuit

Device	OUT (Pin 1)	OUT (Pin 4)	Gain Option	Gain	Gain Error	V _{OS} (MAX)	Gain Drift
				V/V	%	μV	μV/°C
ZXCT180	A	B	1	20	1.0	±400	1
	A	B	2	50	1.0	±400	1
	A	B	3	100	1.0	±400	1
	A	B	4	200	1.0	±400	1

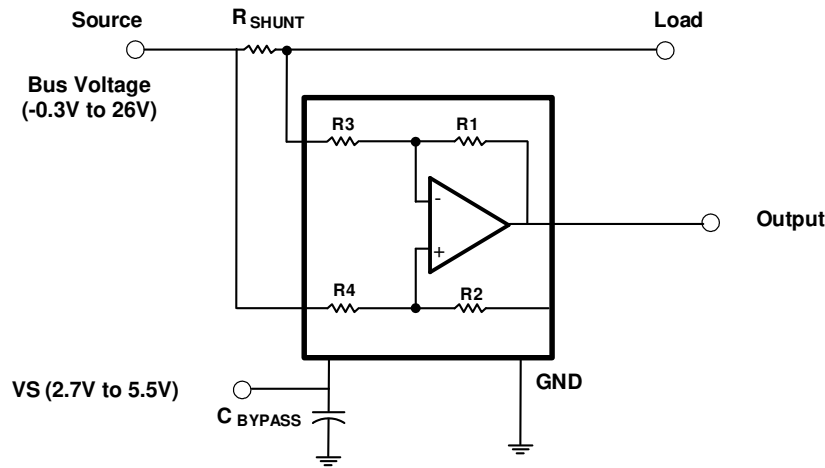

Recommendation of C_{BYPASS} 0.1μF

$$V_{OUT} = (I_{LOAD} \times R_{SHUNT}) \times GAIN$$

Pin Descriptions

Pin Name	Pin Number		I/O	Description
	Pinout A	Pinout B		
GND	2	2	—	Ground
VS	5	5	Power	Power supply, 2.7V to 5.5V
IN+	3	1	Analog input	Connect to supply side of shunt resistor.
IN-	4	3	Analog input	Connect to load side of shunt resistor.
OUT	1	4	Analog output	Output voltage

Absolute Maximum Ratings (@ $T_A = +25^\circ\text{C}$, unless otherwise specified.) (Note 4)

Parameter		Rating	Unit
Supply Voltage (V_S)		+6	V
Analog Inputs IN+, IN-	Differential (IN+)-(IN-)	-28 to 28	V
	Common Mode	GND -0.3 to 26	V
REF Pin Input Voltage		GND- 0.3 to (V_S) + 0.3	V
OUT Pin Output Voltage		GND- 0.3 to (V_S) + 0.3	V
Max. Output Current (Note 5)		8	mA
ESD Human Body ESD Protection (HBM)		5	kV
ESD Charged Device Model ESD Protection (CDM)		1.5	kV
$R_{\theta JA}$ (Junction-to-Ambient Thermal Resistance) (Note 6)		128	$^\circ\text{C}/\text{W}$
$R_{\theta JC}$ (Junction-to-Case Thermal Resistance) (Note 6)		37	$^\circ\text{C}/\text{W}$
Operating Temperature, T_A		-40 to +125	$^\circ\text{C}$
Storage Temperature		-65 to +150	$^\circ\text{C}$

- Notes:
- Stresses greater than those listed under *Absolute Maximum Ratings* can cause permanent damage to the device. These are stress ratings only, and functional operation of the device at these or any other conditions beyond those indicated under *Recommended Operating Conditions* is not implied. Exposure to *Absolute Maximum Ratings* for extended periods can affect device reliability.
 - Input voltage at any pin can exceed the voltage shown if the current at that pin is limited to 5mA.
 - $R_{\theta JA}$ and $R_{\theta JC}$ are measured at $T_A = +25^\circ\text{C}$ on a high effective thermal conductivity minimum recommended pad (MRP) FR-4 PC board.

Recommended Operating Conditions (Note 7)

Symbol	Parameter	Min	Typ	Max	Unit
V_{CM}	Common-Mode Input Voltage	-0.3	12	26	V
V_S	Operating Supply Voltage (applied to VS)	2.7	5	5.5	V
T_A	Operating Ambient Temperature	-40	—	+125	$^\circ\text{C}$

- Note: 7. Refer to the *Typical Applications Circuit*.

Electrical Characteristics ($T_A = +25^\circ\text{C}$, $V_S = 5\text{V}$, $V_{IN+} = 12\text{V}$, $V_{SENSE} = V_{IN+} - V_{IN-}$, and $V_{REF} = V_S / 2$, unless otherwise noted.)

Symbol	Parameter	Test Conditions	Min	Typ	Max	Unit
V_{CM}	Common-Mode Input	$T_A = -40^\circ\text{C}$ to $+125^\circ\text{C}$	-0.3	—	26	V
CMRR	Common-Mode Rejection	$V_{IN+} = 0\text{V}$ to 26V , $V_{SENSE} = 10\text{mV}$	84	110	—	dB
V_{OS}	Offset Voltage, RTI (Note 8)	$V_{SENSE} = 0\text{mV}$, $V_{CM} = 0\text{V}$	—	± 50	± 150	μV
		$V_{SENSE} = 0\text{mV}$, $V_{CM} = 12\text{V}$	—	± 100	± 400	μV
dV_{OS}/dT	V_{OS} vs. Temperature	$T_A = -40^\circ\text{C}$ to $+125^\circ\text{C}$	—	—	1.0	$\mu\text{V}/^\circ\text{C}$
—	Long-Term Stability	Life test 1000 hours with $T_A = +125^\circ\text{C}$ (Note 9)	—	—	± 400	μV
PSRR	Power Supply Rejection	$V_S = 2.7\text{V}$ to 5.5V $V_{IN+} = 12\text{V}$, $V_{SENSE} = 10\text{mV}$	—	± 8	± 40	$\mu\text{V}/\text{V}$
I_B	Input Bias Current	$V_{SENSE} = 0\text{mV}$, $I_{N+} = 0\text{V}$, $I_{N-} = 0\text{V}$	—	-6	—	μA
		$V_{SENSE} = 0\text{mV}$, $I_{N+} = 12\text{V}$, $I_{N-} = 12\text{V}$	—	75	—	μA
I_{OS}	Input Offset Current	$V_{SENSE} = 0\text{mV}$	—	± 0.05	—	μA
G	Gain	ZXCT180A1 / B1	—	20	—	V/V
		ZXCT180A2 / B2	—	50	—	
		ZXCT180A3 / B3	—	100	—	
		ZXCT180A4 / B4	—	200	—	
E_G	Gain Error	$V_{OUT} = 0.5\text{V}$ to Supply Voltage – 0.5V $T_A = -40^\circ\text{C}$ to $+125^\circ\text{C}$	—	$\pm 0.1\%$	$\pm 1\%$	—
—	Gain Error vs. Temperature	$T_A = -40^\circ\text{C}$ to $+125^\circ\text{C}$	—	1.5	20	ppm/ $^\circ\text{C}$
—	Nonlinearity Error	$V_{OUT} = 0.5\text{V}$ to Supply Voltage – 0.5V	—	$\pm 0.01\%$	—	—
V_{OH}	Swing to V_S Power-Supply Rail	$R_L = 10\text{k}\Omega$ to GND, $T_A = -40^\circ\text{C}$ to $+125^\circ\text{C}$	—	$(V_S) - 0.02$	$(V_S) - 0.03$	V
V_{OL}	Swing to GND	$R_L = 10\text{k}\Omega$ to GND, $T_A = -40^\circ\text{C}$ to $+125^\circ\text{C}$	—	$(V_{GND}) + 0.0005$	$(V_{GND}) + 0.005$	V
—	Maximum Capacitive Load	No sustained oscillation	—	1	—	nF
GBW	Bandwidth	$C_{LOAD} = 10\text{pF}$, ZXCT180A1 / B1	—	400	—	kHz
		$C_{LOAD} = 10\text{pF}$, ZXCT180A2 / B2	—	300	—	
		$C_{LOAD} = 10\text{pF}$, ZXCT180A3 / B3	—	150	—	
		$C_{LOAD} = 10\text{pF}$, ZXCT180A4 / B4	—	85	—	
SR	Slew Rate	—	—	2	—	V/ μs
—	Voltage Noise Density	—	—	40	—	nV/ $\sqrt{\text{Hz}}$
V_S	Operating Voltage Range	$T_A = -40^\circ\text{C}$ to $+125^\circ\text{C}$	2.7	—	5.5	V
I_Q	Quiescent Current	$V_{SENSE} = 10\text{mV}$	—	250	355	μA
		$V_{SENSE} = 10\text{mV}$, $T_A = -40^\circ\text{C}$ to $+125^\circ\text{C}$	—	—	370	μA
—	Specified Range	—	-40	—	+125	$^\circ\text{C}$
—	Operating Range	—	-40	—	+125	$^\circ\text{C}$

Notes: 8. RTI = Referred to input

9. For the long-term stability, the maximum V_{OS} shift with time has been calculated during life test 1000 hours with $T_A = +125^\circ\text{C}$.

This V_{OS} drift with time is not a linear function of time, and the shift is great initially and slows down (becomes linear) over time. This parameter is guaranteed by design.

Typical Performance Characteristics

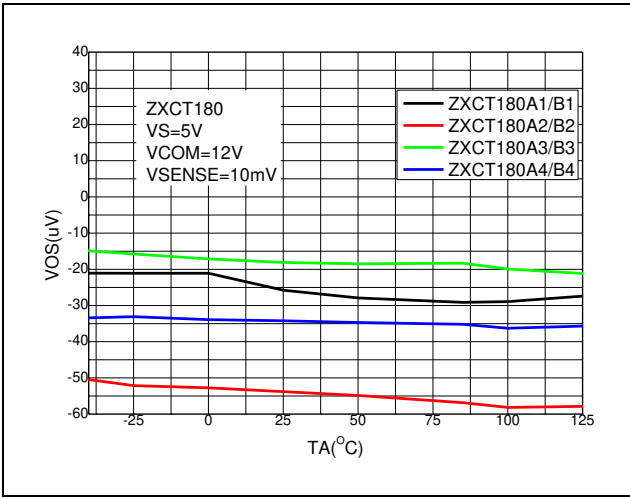

Figure 1. Offset Voltage vs. Temperature

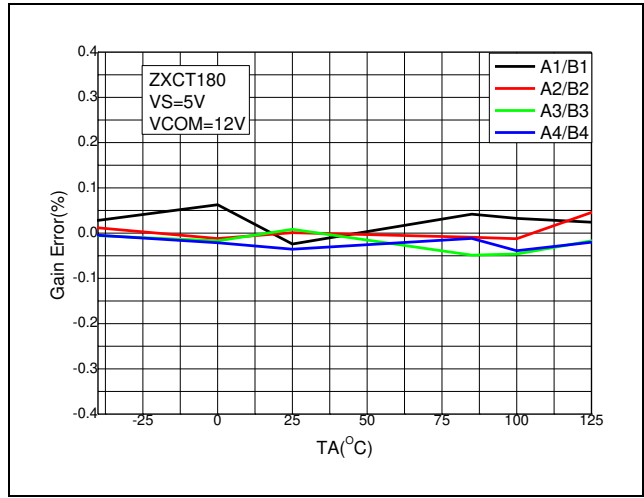

Figure 2. Gain Error vs. Temperature

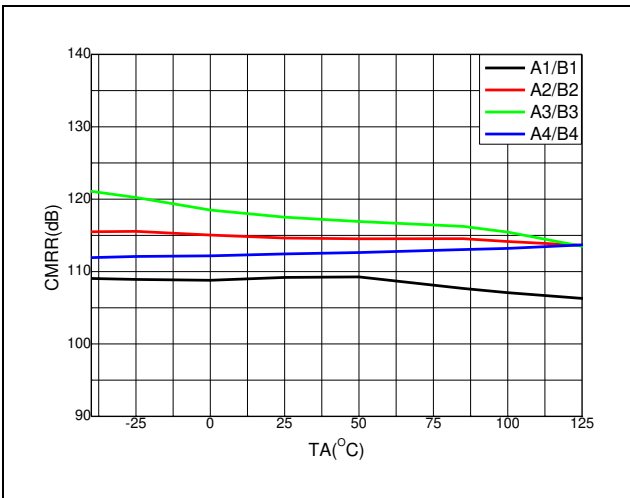

Figure 3. CMRR vs. Temperature

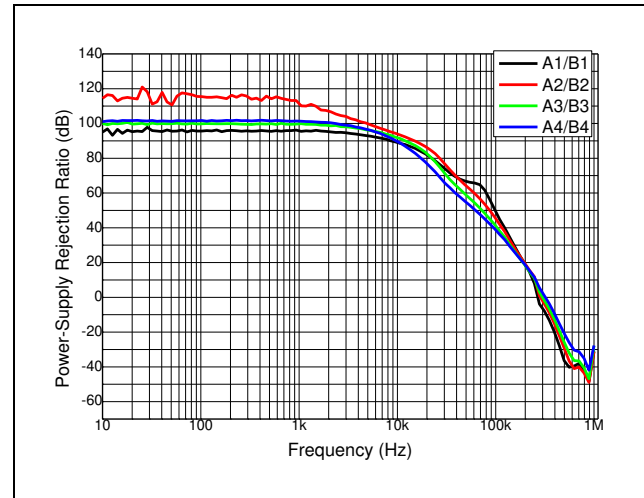

Figure 4. PSRR vs. Frequency

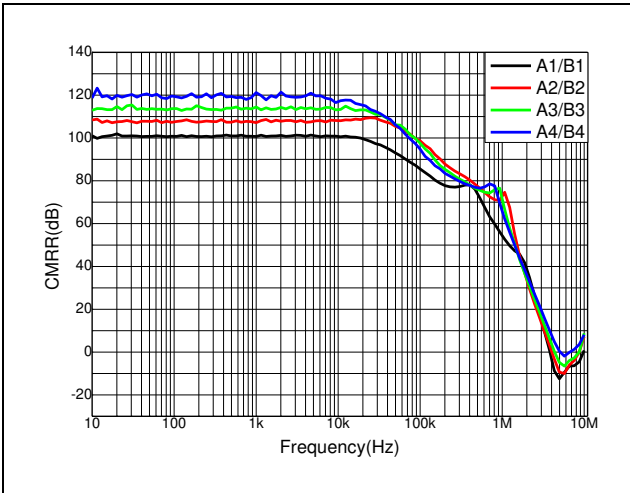

Figure 5. CMRR vs. Frequency

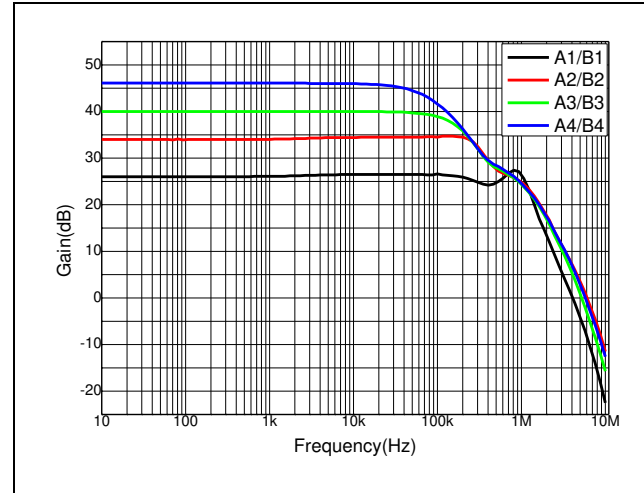

Figure 6. Gain vs. Frequency

Typical Performance Characteristics (continued)

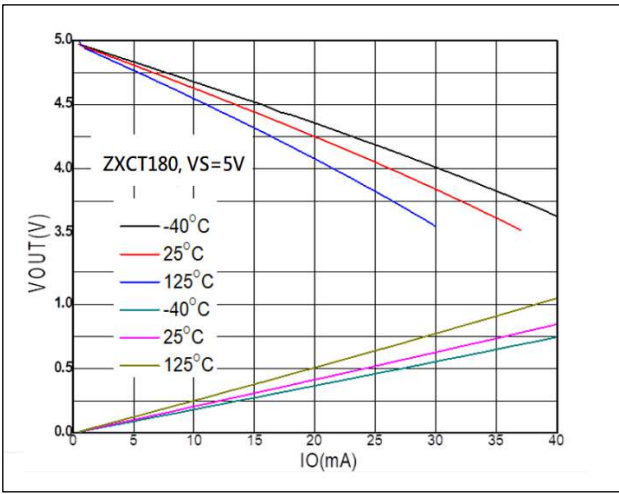

Figure 7. Output Voltage Swing vs. Output Current

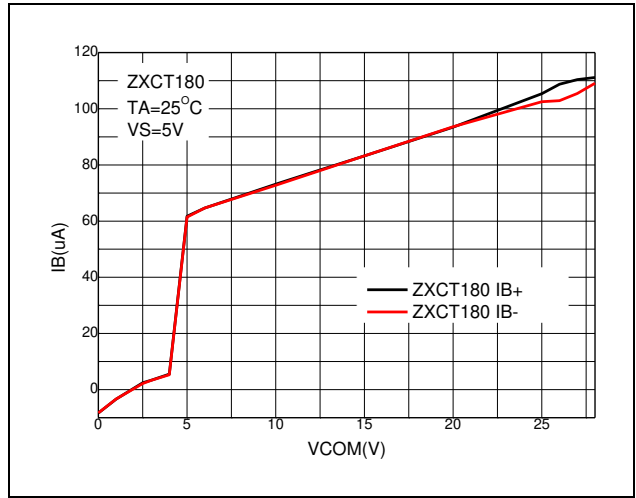

Figure 8. Input Bias Current vs. Common-Mode Voltage

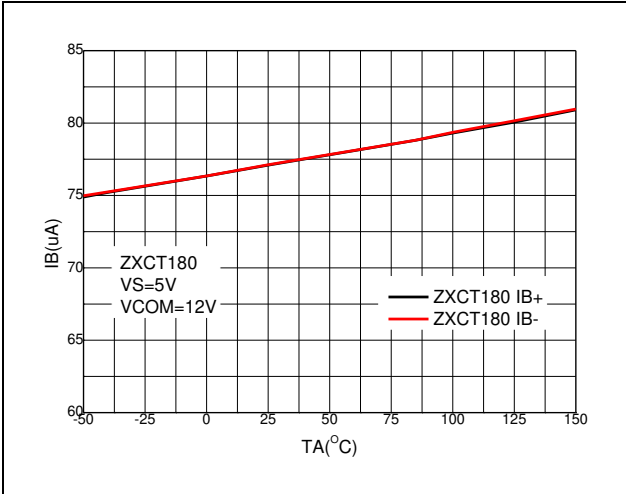

Figure 9. Input Bias Current vs. Temperature

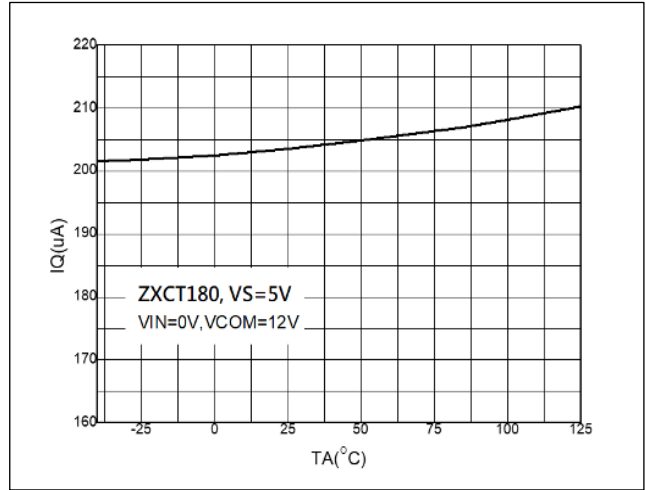

Figure 10. Quiescent Current vs. Temperature

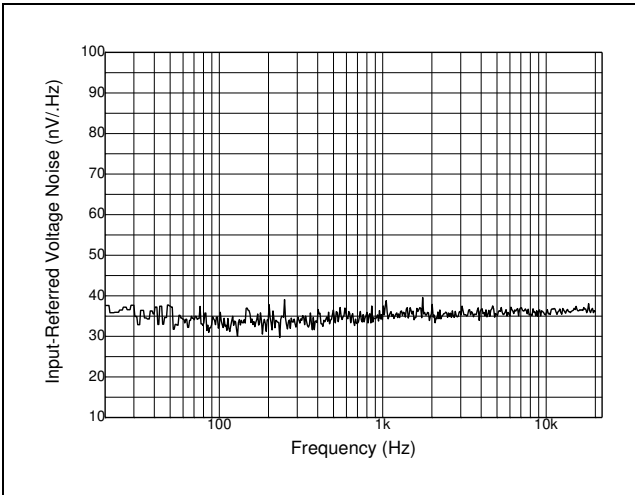

Figure 11. Input Noise Voltage vs. Frequency

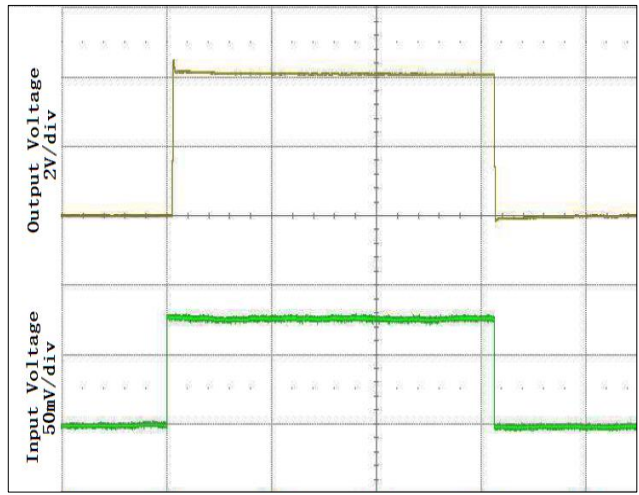

Figure 12. Step Response for A2 (G=50), Input 80mV vs. Output 2V

Application Information

General Information

The ZXCT180 has a wide common mode of -0.3V to 26V and it can be used in low-side and high-side current sensing. The device is a specially designed, current-sensing amplifier able to accurately measure voltages developed across a current-sensing resistor on common-mode voltages that far exceed the supply voltage powering the device. The chip topology enables high-precision measurements with maximum input offset voltages as low as 400 μ V, with a maximum temperature contribution of 1.0 μ V/ $^{\circ}$ C over the full temperature range of -40 $^{\circ}$ C to +125 $^{\circ}$ C.

Input and Output Pin Voltage Ranges

The ZXCT180 can withstand the full input signal range of up to 26V at the input sense pins, regardless of whether the device has power applied or has the VS pin at zero volts. The input circuitry of the ZXCT180 can accurately measure beyond its power-supply voltage. For example, the VS power supply is 5V, whereas the voltage applied to the analog input pins IN+ or IN- can be as high as 26V. At the moment, the output voltage range of the OUT pin is limited by the voltage on the power supply and a consideration of the maximum V_{OH}.

Power Supply Recommendations

The ZXCT180 can operate on as low as 2.7V. In some applications the power supply may be selected to limit the output range that is compatible with parts using this signal such as an analog converter or an analog input pin on a microcontroller. The power supply has been set at 5V. This will limit the output voltage of the current monitor. The ground connections for the ADC and current monitor should be wired as a star configuration to minimize error. A power-supply bypass capacitor connected closely to the device pins is required for stability with a suggested value of 0.1 μ F. Please place the power-supply bypass capacitor as close as possible to the device power supply and ground pins. Additional decoupling capacitance can be added to compensate for noisy or high-impedance power supplies.

Figure 13 shows the basic connections of the ZXCT180. Connect the input pins (IN+ and IN-) as closely as possible to the shunt resistor to minimize any resistance in series with the shunt resistor.

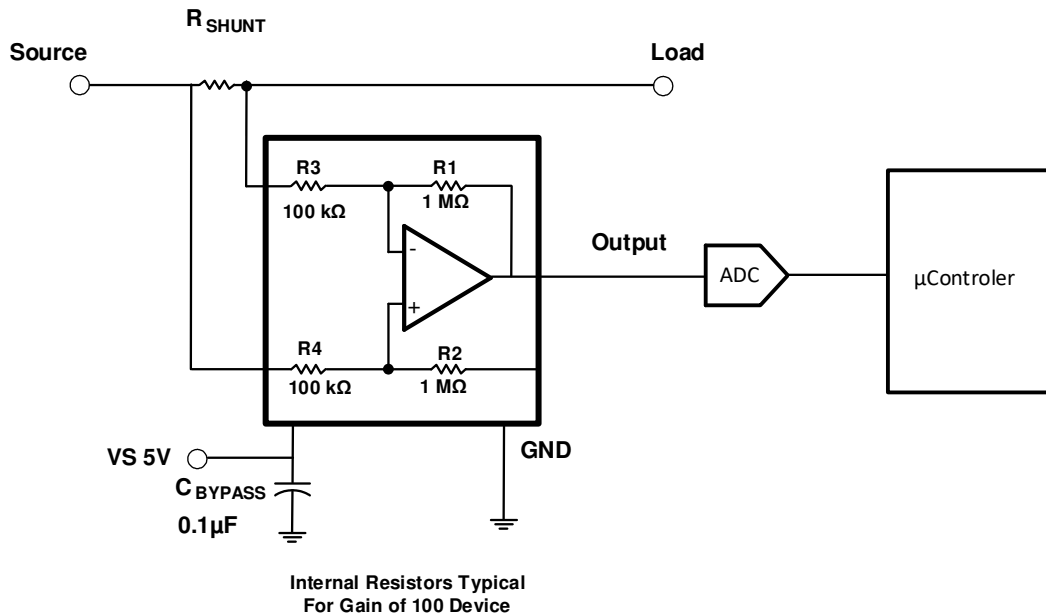
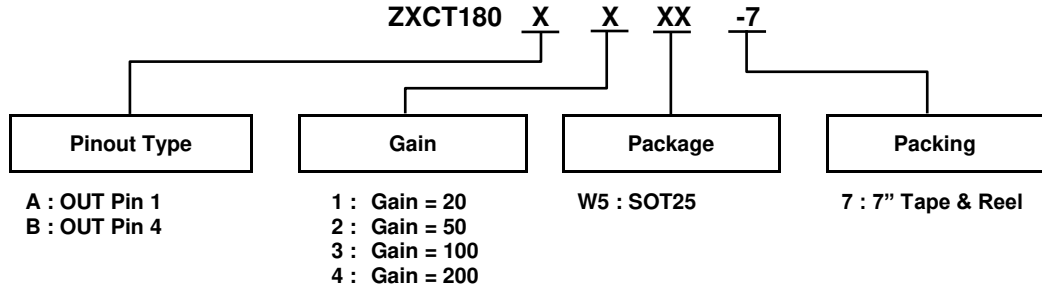

Figure 13. Typical Application

Ordering Information



Orderable Part Number	Output	Package Code	Package	Packing	
				Qty.	Carrier
ZXCT180A1W5-7	Pin 1	W5	SOT25	3000	7" Tape & Reel
ZXCT180A2W5-7	Pin 1	W5	SOT25	3000	7" Tape & Reel
ZXCT180A3W5-7	Pin 1	W5	SOT25	3000	7" Tape & Reel
ZXCT180A4W5-7	Pin 1	W5	SOT25	3000	7" Tape & Reel
ZXCT180B1W5-7	Pin 4	W5	SOT25	3000	7" Tape & Reel
ZXCT180B2W5-7	Pin 4	W5	SOT25	3000	7" Tape & Reel
ZXCT180B3W5-7	Pin 4	W5	SOT25	3000	7" Tape & Reel
ZXCT180B4W5-7	Pin 4	W5	SOT25	3000	7" Tape & Reel

Marking Information

(Top View)

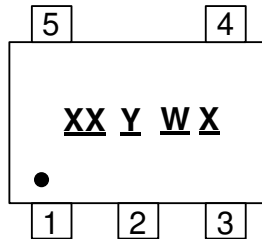

- XX : Identification Code
- Y : Year 0 to 9 (ex: 4 = 2024)
- W : Week : A to Z : week 1 to 26;
a to z : week 27 to 52; z represents week 52 and 53
- X : Internal Code

Orderable Part Number	Package	Identification Code
ZXCT180A1W5-7	SOT25	MA
ZXCT180A2W5-7	SOT25	MB
ZXCT180A3W5-7	SOT25	MC
ZXCT180A4W5-7	SOT25	MD
ZXCT180B1W5-7	SOT25	ME
ZXCT180B2W5-7	SOT25	MF
ZXCT180B3W5-7	SOT25	MG
ZXCT180B4W5-7	SOT25	MH

Package Outline Dimensions

Please see <http://www.diodes.com/package-outlines.html> for the latest version.

SOT25

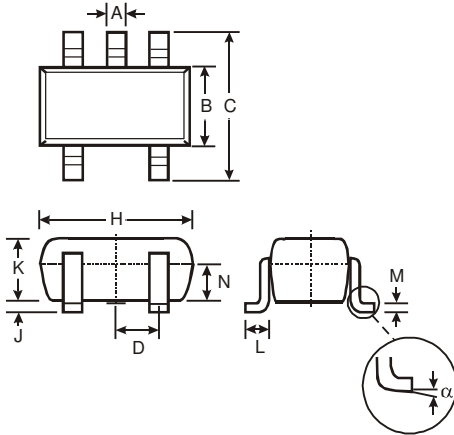

SOT25			
Dim	Min	Max	Typ
A	0.35	0.50	0.38
B	1.50	1.70	1.60
C	2.70	3.00	2.80
D	-	-	0.95
H	2.90	3.10	3.00
J	0.013	0.10	0.05
K	1.00	1.30	1.10
L	0.35	0.55	0.40
M	0.10	0.20	0.15
N	0.70	0.80	0.75
α	0°	8°	-
All Dimensions in mm			

Suggested Pad Layout

Please see <http://www.diodes.com/package-outlines.html> for the latest version.

SOT25

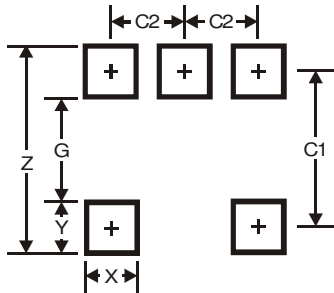

Dimensions	Value
Z	3.20
G	1.60
X	0.55
Y	0.80
C1	2.40
C2	0.95

Mechanical Data

SOT25

- Moisture Sensitivity: Level 1 per J-STD-020
- Terminals: Finish – Matte Tin Plated Leads, Solderable per MIL-STD-202, Method 208 (e3)
- Weight: 0.012 grams (Approximate)
- Max Soldering Temperature +260°C for 30 secs as per JEDEC J-STD-020

IMPORTANT NOTICE

1. DIODES INCORPORATED (Diodes) AND ITS SUBSIDIARIES MAKE NO WARRANTY OF ANY KIND, EXPRESS OR IMPLIED, WITH REGARDS TO ANY INFORMATION CONTAINED IN THIS DOCUMENT, INCLUDING, BUT NOT LIMITED TO, THE IMPLIED WARRANTIES OF MERCHANTABILITY, FITNESS FOR A PARTICULAR PURPOSE OR NON-INFRINGEMENT OF THIRD PARTY INTELLECTUAL PROPERTY RIGHTS (AND THEIR EQUIVALENTS UNDER THE LAWS OF ANY JURISDICTION).
2. The Information contained herein is for informational purpose only and is provided only to illustrate the operation of Diodes' products described herein and application examples. Diodes does not assume any liability arising out of the application or use of this document or any product described herein. This document is intended for skilled and technically trained engineering customers and users who design with Diodes' products. Diodes' products may be used to facilitate safety-related applications; however, in all instances customers and users are responsible for (a) selecting the appropriate Diodes products for their applications, (b) evaluating the suitability of Diodes' products for their intended applications, (c) ensuring their applications, which incorporate Diodes' products, comply the applicable legal and regulatory requirements as well as safety and functional-safety related standards, and (d) ensuring they design with appropriate safeguards (including testing, validation, quality control techniques, redundancy, malfunction prevention, and appropriate treatment for aging degradation) to minimize the risks associated with their applications.
3. Diodes assumes no liability for any application-related information, support, assistance or feedback that may be provided by Diodes from time to time. Any customer or user of this document or products described herein will assume all risks and liabilities associated with such use, and will hold Diodes and all companies whose products are represented herein or on Diodes' websites, harmless against all damages and liabilities.
4. Products described herein may be covered by one or more United States, international or foreign patents and pending patent applications. Product names and markings noted herein may also be covered by one or more United States, international or foreign trademarks and trademark applications. Diodes does not convey any license under any of its intellectual property rights or the rights of any third parties (including third parties whose products and services may be described in this document or on Diodes' website) under this document.
5. Diodes' products are provided subject to Diodes' Standard Terms and Conditions of Sale (<https://www.diodes.com/about/company/terms-and-conditions/terms-and-conditions-of-sales/>) or other applicable terms. This document does not alter or expand the applicable warranties provided by Diodes. Diodes does not warrant or accept any liability whatsoever in respect of any products purchased through unauthorized sales channel.
6. Diodes' products and technology may not be used for or incorporated into any products or systems whose manufacture, use or sale is prohibited under any applicable laws and regulations. Should customers or users use Diodes' products in contravention of any applicable laws or regulations, or for any unintended or unauthorized application, customers and users will (a) be solely responsible for any damages, losses or penalties arising in connection therewith or as a result thereof, and (b) indemnify and hold Diodes and its representatives and agents harmless against any and all claims, damages, expenses, and attorney fees arising out of, directly or indirectly, any claim relating to any noncompliance with the applicable laws and regulations, as well as any unintended or unauthorized application.
7. While efforts have been made to ensure the information contained in this document is accurate, complete and current, it may contain technical inaccuracies, omissions and typographical errors. Diodes does not warrant that information contained in this document is error-free and Diodes is under no obligation to update or otherwise correct this information. Notwithstanding the foregoing, Diodes reserves the right to make modifications, enhancements, improvements, corrections or other changes without further notice to this document and any product described herein. This document is written in English but may be translated into multiple languages for reference. Only the English version of this document is the final and determinative format released by Diodes.
8. Any unauthorized copying, modification, distribution, transmission, display or other use of this document (or any portion hereof) is prohibited. Diodes assumes no responsibility for any losses incurred by the customers or users or any third parties arising from any such unauthorized use.
9. This Notice may be periodically updated with the most recent version available at <https://www.diodes.com/about/company/terms-and-conditions/important-notice>

The Diodes logo is a registered trademark of Diodes Incorporated in the United States and other countries.
All other trademarks are the property of their respective owners.
© 2024 Diodes Incorporated. All Rights Reserved.

www.diodes.com