

## Description

The ZXCT181Q is automotive AEC-Q qualified current shunt monitor which is designed to be a cost-effective solution to deal with 26V common-mode and a smaller supply voltage range 2.7V to 5.5V powering the device.

The ZXCT181Q supports the small-signal bandwidths as high as 400kHz at 20V/V gain and fast large-signal slew rates of 2V/μs. This ability can be used to detect rapid changes in the sensed current and fast response to the output so that these features make the ZXCT181Q a good choice for applications such as low-side motor control and the system fault current detection.

For the bi-directional current sense, it can be achieved by applying a voltage at the REF pin to offset the output voltage. Likewise, tie the REF pin to GND to be a unidirectional current monitor. In unidirectional applications, if measuring a very low input current is desirable, the REF pin connecting to GND may result in an inaccurate measurement so that putting a bias voltage above 50mV on REF pin is recommended to make the output into the linear range of the device.

The ZXCT181Q series has four fixed voltage gain options in 20V/V, 50V/V, 100V/V, and 200V/V. It can measure voltage across shunts at common-mode voltages from -0.3V to 26V, independent of supply voltage with a maximum supply current of 300μA. All versions are specified with temperature range of -40°C to +125°C, and available in SOT26 package.

## Features

- Supply Voltage Range: 2.7V to 5.5V
- Wide Common-Mode Range: -0.3V to 26V
- Gain Error: (Maximum over Temperature): ±1%
- Choice of Gains:
  - Version A1: 20V/V
  - Version A2: 50V/V
  - Version A3: 100V/V
  - Version A4: 200V/V
- Low Offset Voltage: Typical ±100μV and 1-μV/°C Drift
- Rail-to-Rail Output Capability
- Low Quiescent Current: 300μA (max)
- Package: 6-Pin SOT26
- ESD Protection JESD 22, 5000V HBM (A114)
- **Totally Lead-Free & Fully RoHS Compliant (Notes 1 & 2)**
- **Halogen and Antimony Free. "Green" Device (Note 3)**
- **The ZXCT181Q is suitable for automotive applications requiring specific change control; this part is AEC-Q100 qualified, PPAP capable, and manufactured in IATF16949 certified facilities.**

<https://www.diodes.com/quality/product-definitions/>

- Notes:
1. No purposely added lead. Fully EU Directive 2002/95/EC (RoHS), 2011/65/EU (RoHS 2) & 2015/863/EU (RoHS 3) compliant.
  2. See <https://www.diodes.com/quality/lead-free/> for more information about Diodes Incorporated's definitions of Halogen- and Antimony-free, "Green" and Lead-free.
  3. Halogen- and Antimony-free "Green" products are defined as those which contain <900ppm bromine, <900ppm chlorine (<1500ppm total Br + Cl) and <1000ppm antimony compounds.

## Pin Assignments

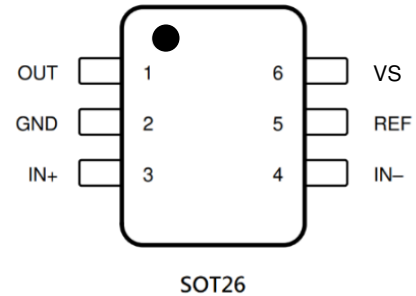

## Applications

- Vehicle valve controls
- Vehicle body control systems
- Vehicle motor controls, e-pumps
- Vehicle lighting controls
- Fault current detection
- Wireless charging
- Current sensing (high-side/low-side)
- Battery charging and discharging

**Typical Applications Circuit**

Device	Version	Gain	Gain Error	V <sub>OS</sub> (MAX)	Gain Drift
		V/V	%	µV	µV/°C
ZXCT181Q	A1	20	1.0	±400	1
	A2	50	1.0	±400	1
	A3	100	1.0	±400	1
	A4	200	1.0	±400	1

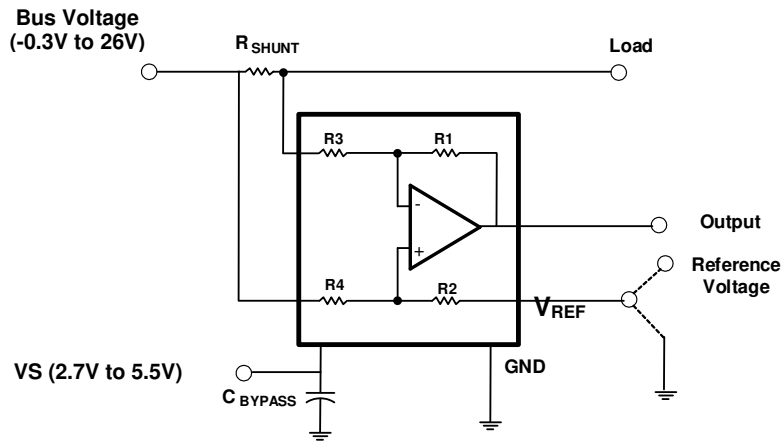

$$V_{OUT} = (I_{LOAD} \times R_{SHUNT}) \times GAIN + V_{REF}$$

**Pin Descriptions**

Pin Name	Pin Number	I/O	Description
OUT	1	Analog output	Output voltage
GND	2	—	Ground
IN+	3	Analog input	Connect to supply side of shunt resistor.
IN-	4	Analog input	Connect to load side of shunt resistor.
REF	5	Analog input	Reference voltage, 0V to V <sub>s</sub>
VS	6	Power	Power supply, 2.7V to 5.5V

**Absolute Maximum Ratings** (@  $T_A = +25^\circ\text{C}$ , unless otherwise specified.) (Note 4)

Parameter		Rating	Unit
Supply Voltage ( $V_S$ )		+6	V
Analog Inputs IN+, IN-	Differential (IN+)-(IN-)	-28 to 28	V
	Common Mode	GND -0.3 to 26	V
REF Pin Input Voltage		GND- 0.3 to ( $V_S$ ) + 0.3	V
OUT Pin Output Voltage		GND- 0.3 to ( $V_S$ ) + 0.3	V
Max. Output Current (Note 5)		8	mA
ESD Human Body ESD Protection (HBM)		5	kV
ESD Charged Device Model ESD Protection (CDM)		1.5	kV
$R_{\theta JA}$ (Junction-to-Ambient Thermal Resistance) (Note 6)		124	$^\circ\text{C}/\text{W}$
$R_{\theta JC}$ (Junction-to-Case Thermal Resistance) (Note 6)		32	$^\circ\text{C}/\text{W}$
Operating Temperature, $T_A$		-40 to +125	$^\circ\text{C}$
Storage Temperature		-65 to +150	$^\circ\text{C}$

- Notes:
- Stresses greater than those listed under *Absolute Maximum Ratings* can cause permanent damage to the device. These are stress ratings only, and functional operation of the device at these or any other conditions beyond those indicated under *Recommended Operating Conditions* is not implied. Exposure to *Absolute Maximum Ratings* for extended periods can affect device reliability.
  - Input voltage at any pin can exceed the voltage shown if the current at that pin is limited to 5mA.
  - $R_{\theta JA}$  and  $R_{\theta JC}$  are measured at  $T_A = +25^\circ\text{C}$  on a high effective thermal conductivity minimum recommended pad (MRP) FR-4 PC board.

**Recommended Operating Conditions** (Note 7)

Symbol	Parameter	Min	Typ	Max	Unit
$V_{CM}$	Common-Mode Input Voltage	-0.3	12	26	V
$V_S$	Operating Supply Voltage (applied to $V_S$ )	2.7	5	5.5	V
$T_A$	Operating Ambient Temperature	-40	—	+125	$^\circ\text{C}$

- Note: 7. Refer to the *Typical Applications Circuit*.

**Electrical Characteristics** ( $T_A = +25^\circ\text{C}$ ,  $V_S = 5\text{V}$ ,  $V_{IN+} = 12\text{V}$ ,  $V_{SENSE} = V_{IN+} - V_{IN-}$ , and  $V_{REF} = V_S / 2$ , unless otherwise noted.)

Symbol	Parameter	Test Conditions	Min	Typ	Max	Unit
$V_{CM}$	Common-Mode Input	$T_A = -40^\circ\text{C}$ to $+125^\circ\text{C}$	-0.3	—	26	V
CMRR	Common-Mode Rejection	ZXCT181QX1, $V_{IN+} = 0\text{V}$ to $26\text{V}$ , $V_{SENSE} = 0\text{mV}$	84	110	—	dB
$V_{OS}$	Offset Voltage, RTI (Note 8)	$V_{SENSE} = 0\text{mV}$ , $V_{CM} = 0\text{V}$	—	$\pm 50$	$\pm 150$	$\mu\text{V}$
		$V_{SENSE} = 0\text{mV}$ , $V_{CM} = 12\text{V}$	—	$\pm 100$	$\pm 400$	$\mu\text{V}$
$dV_{OS}/dT$	$V_{OS}$ vs. Temperature	$T_A = -40^\circ\text{C}$ to $+125^\circ\text{C}$	—	—	1.0	$\mu\text{V}/^\circ\text{C}$
—	Long-Term Stability	Life test 1000 hours with $T_A = +125^\circ\text{C}$ (Note 9)	—	—	$\pm 400$	$\mu\text{V}$
PSRR	Power Supply Rejection	$V_S = 2.7\text{V}$ to $5.5\text{V}$ $V_{IN+} = 12\text{V}$ , $V_{SENSE} = 0\text{mV}$	—	$\pm 8$	$\pm 40$	$\mu\text{V}/\text{V}$
$I_B$	Input Bias Current	$V_{SENSE} = 0\text{mV}$ , $I_{N+} = 0\text{V}$ , $I_{N-} = 0\text{V}$	—	-6	—	$\mu\text{A}$
		$V_{SENSE} = 0\text{mV}$ , $I_{N+} = 12\text{V}$ , $I_{N-} = 12\text{V}$	—	75	—	$\mu\text{A}$
$I_{OS}$	Input Offset Current	$V_{SENSE} = 0\text{mV}$	—	$\pm 0.05$	—	$\mu\text{A}$
G	Gain	ZXCT181QA1	—	20	—	V/V
		ZXCT181QA2	—	50	—	
		ZXCT181QA3	—	100	—	
		ZXCT181QA4	—	200	—	
$E_G$	Gain Error	$V_{OUT} = 0.5\text{V}$ to Supply Voltage – $0.5\text{V}$ $T_A = -40^\circ\text{C}$ to $+125^\circ\text{C}$	—	$\pm 0.1\%$	$\pm 1\%$	—
—	Gain Error vs. Temperature	$T_A = -40^\circ\text{C}$ to $+125^\circ\text{C}$	—	1.5	20	$\text{ppm}/^\circ\text{C}$
—	Nonlinearity Error	$V_{OUT} = 0.5\text{V}$ to Supply Voltage – $0.5\text{V}$	—	$\pm 0.01\%$	—	—
$V_{OH}$	Swing to $V_S$ Power-Supply Rail	$R_L = 10\text{k}\Omega$ to GND, $T_A = -40^\circ\text{C}$ to $+125^\circ\text{C}$	—	$(V_S) - 0.02$	$(V_S) - 0.03$	V
$V_{OL}$	Swing to GND	$R_L = 10\text{k}\Omega$ to GND, $T_A = -40^\circ\text{C}$ to $+125^\circ\text{C}$	—	$(V_{GND}) + 0.0005$	$(V_{GND}) + 0.005$	V
—	Maximum Capacitive Load	No sustained oscillation	—	1	—	nF
GBW	Band Width	$C_{LOAD} = 10\text{pF}$ , ZXCT181QA1	—	400	—	kHz
		$C_{LOAD} = 10\text{pF}$ , ZXCT181QA2	—	300	—	
		$C_{LOAD} = 10\text{pF}$ , ZXCT181QA3	—	150	—	
		$C_{LOAD} = 10\text{pF}$ , ZXCT181QA4	—	85	—	
SR	Slew Rate	—	—	2	—	$\text{V}/\mu\text{s}$
—	Voltage Noise Density	—	—	40	—	$\text{nV}/\sqrt{\text{Hz}}$
$V_S$	Operating Voltage Range	$T_A = -40^\circ\text{C}$ to $+125^\circ\text{C}$	2.7	—	5.5	V
$I_Q$	Quiescent Current	$V_{SENSE} = 0\text{mV}$	—	200	260	$\mu\text{A}$
		$T_A = -40^\circ\text{C}$ to $+125^\circ\text{C}$	—	—	300	$\mu\text{A}$
—	Specified Range	—	-40	—	+125	$^\circ\text{C}$
—	Operating Range	—	-40	—	+125	$^\circ\text{C}$

Notes: 8. RTI = Referred to input  
9. For the long-term stability, the maximum  $V_{OS}$  shift with time has been calculated during life test 1000 hours with  $T_A = +125^\circ\text{C}$ . This  $V_{OS}$  drift with time is not a linear function of time, and the shift is great initially and slows down (becomes linear) over time. This parameter is guaranteed by design.

**Typical Performance Characteristics**

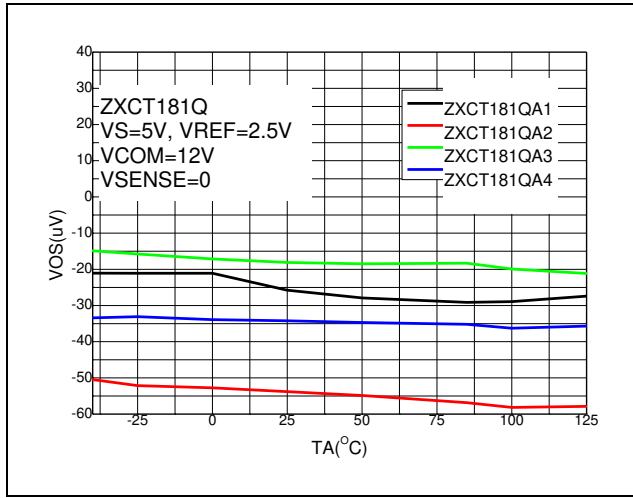

Figure 1. Offset Voltage vs. Temperature

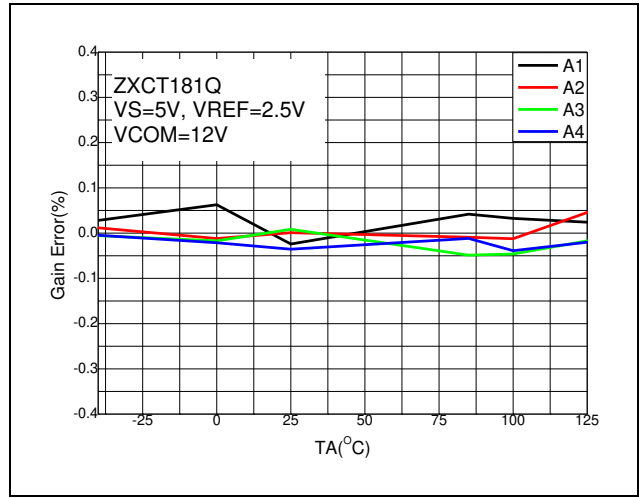

Figure 2. Gain Error vs. Temperature

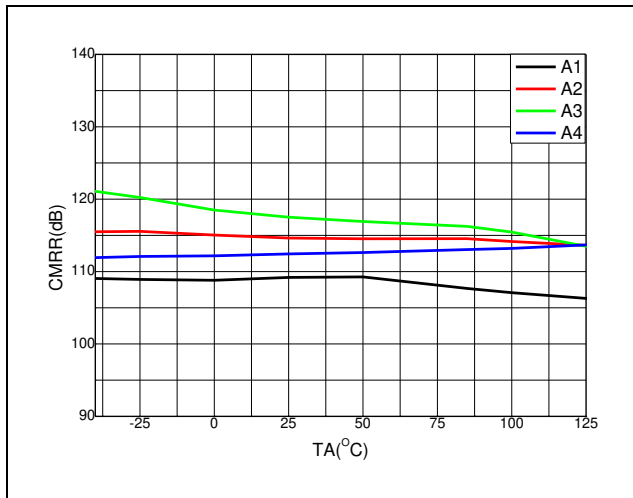

Figure 3. CMRR vs. Temperature

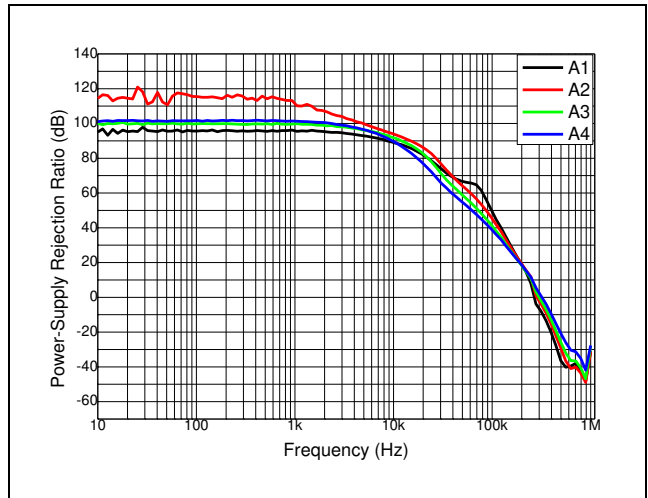

Figure 4. PSRR vs. Frequency

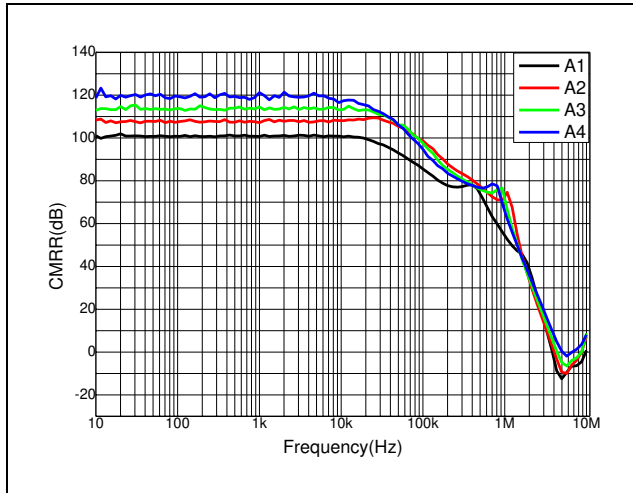

Figure 5. CMRR vs. Frequency

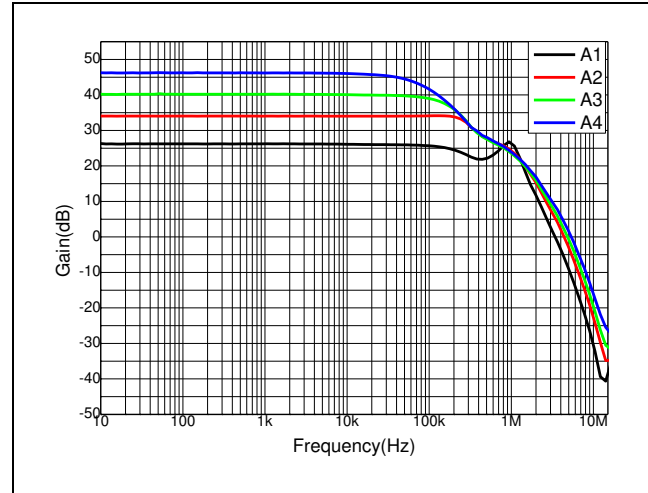

Figure 6. Gain vs. Frequency

**Typical Performance Characteristics** (continued)

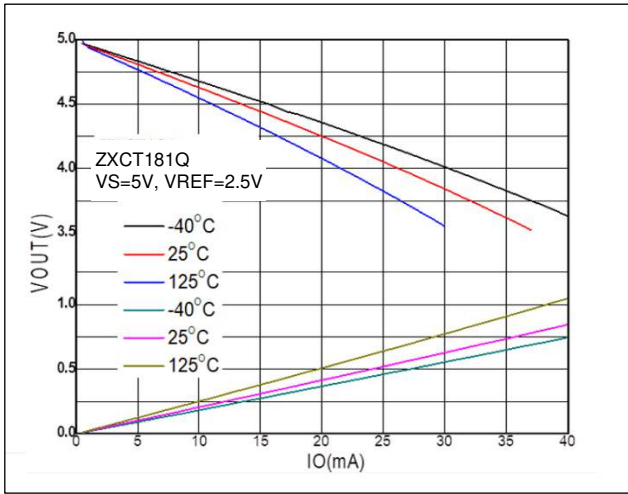

Figure 7. Output Voltage Swing vs. Output Current

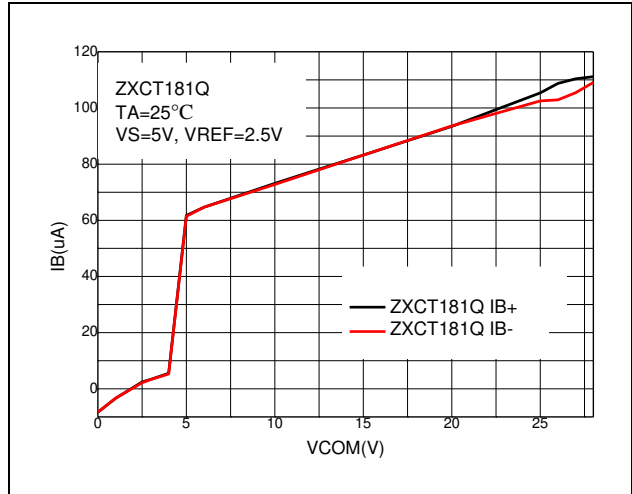

Figure 8. Input Bias Current vs. Common-Mode Voltage

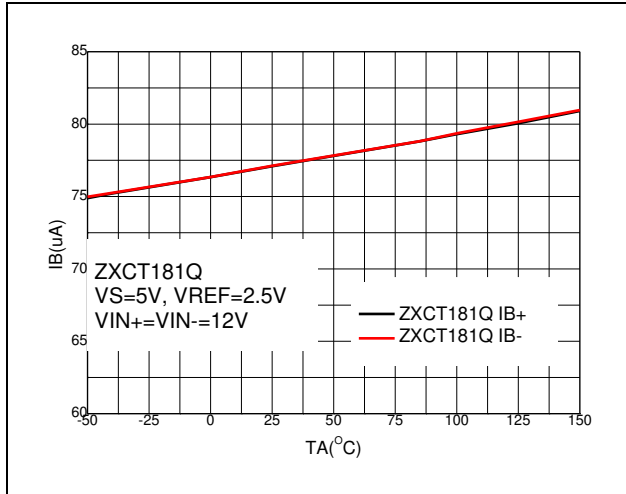

Figure 9. Input Bias Current vs. Temperature

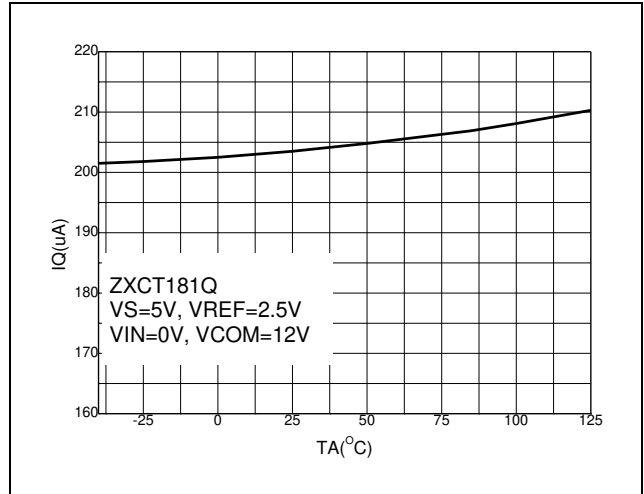

Figure 10. Quiescent Current vs. Temperature

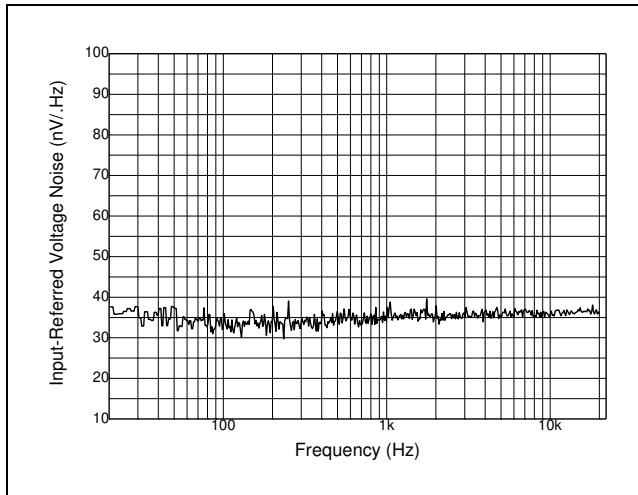

Figure 11. Input Noise Voltage vs. Frequency

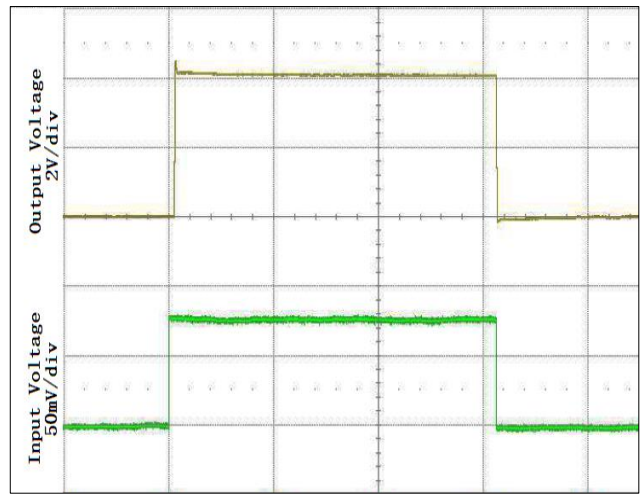

Figure 12. Step Response for A2 (G=50), Input 80mV vs. Output 2V

## Application Information

### General Information

The ZXCT181Q has a wide common mode of -0.3V to 26V and it can be used in low-side and high-side current sensing. The device is a specially designed, current-sensing amplifier able to accurately measure voltages developed across a current-sensing resistor on common-mode voltages that far exceed the supply voltage powering the device. The chip topology enables high-precision measurements with maximum input offset voltages as low as 400 $\mu$ V, with a maximum temperature contribution of 1.0 $\mu$ V/ $^{\circ}$ C over the full temperature range of -40 $^{\circ}$ C to +125 $^{\circ}$ C.

### Input and Output Pin Voltage Ranges

The ZXCT181Q can withstand the full input signal range of up to 26V at the input sense pins, regardless of whether the device has power applied or has the VS pin at zero volts. The input circuitry of the ZXCT181Q can accurately measure beyond its power-supply voltage. For example, the VS power supply is 5V, whereas the voltage applied to the analog input pins IN+ or IN- can be as high as 26V. At the moment, the output voltage range of the OUT pin is limited by the voltage on the power supply and a consideration of the maximum V<sub>OH</sub>.

### Power Supply Recommendations

The ZXCT181Q can operate on as low as 2.7V. In some applications the power supply may be selected to limit the output range that is compatible with parts using this signal such as an analog converter or an analog input pin on a microcontroller. The power supply has been set at 5V. This will limit the output voltage of the current monitor. The ground connections for the ADC and current monitor should be wired as a star configuration to minimize error. A power-supply bypass capacitor connected closely to the device pins is required for stability with a suggested value of 0.1 $\mu$ F. Please place the power-supply bypass capacitor as close as possible to the device power supply and ground pins. Additional decoupling capacitance can be added to compensate for noisy or high-impedance power supplies.

Figure 13 shows the basic connections of the ZXCT181Q. Connect the input pins (IN+ and IN-) as closely as possible to the shunt resistor to minimize any resistance in series with the shunt resistor.

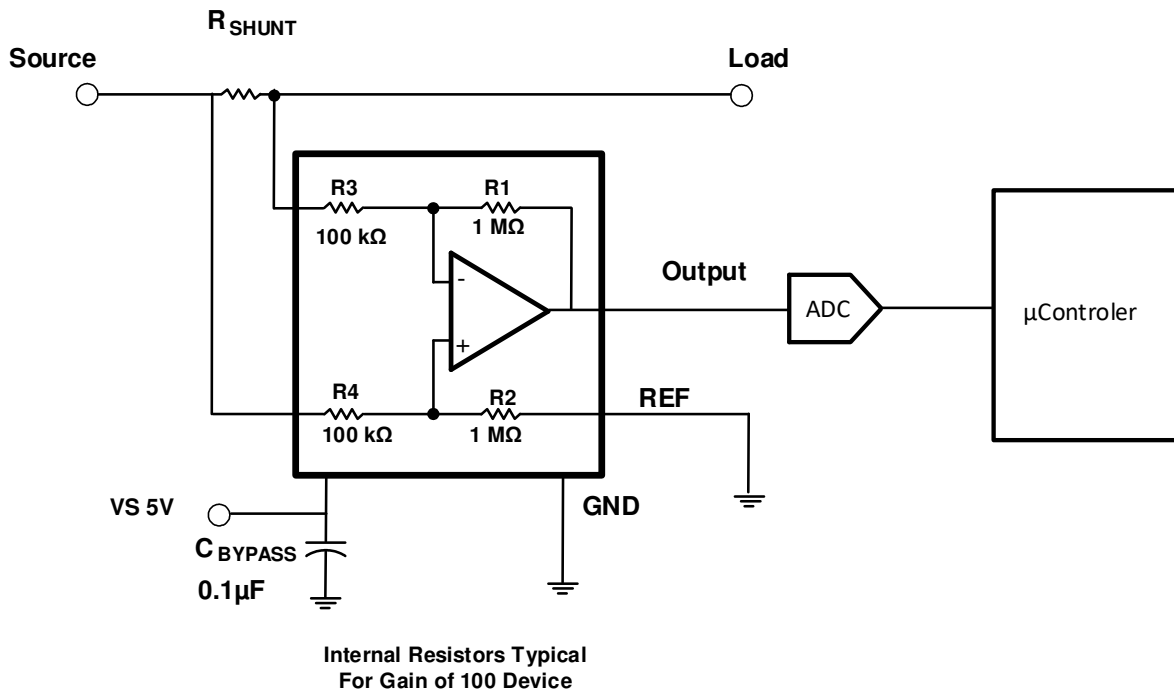

Figure 13. Typical Application

**Application Information** (continued)

**Single-Direction Operation**

The device is configured to monitor current flowing in one direction (single direction) or in both directions (bi-directional) depending on how the REF pin is configured. With the REF connected to the ground as depicted in Figure 14, the device will measure only signals that impose a positive voltage across the shunt.

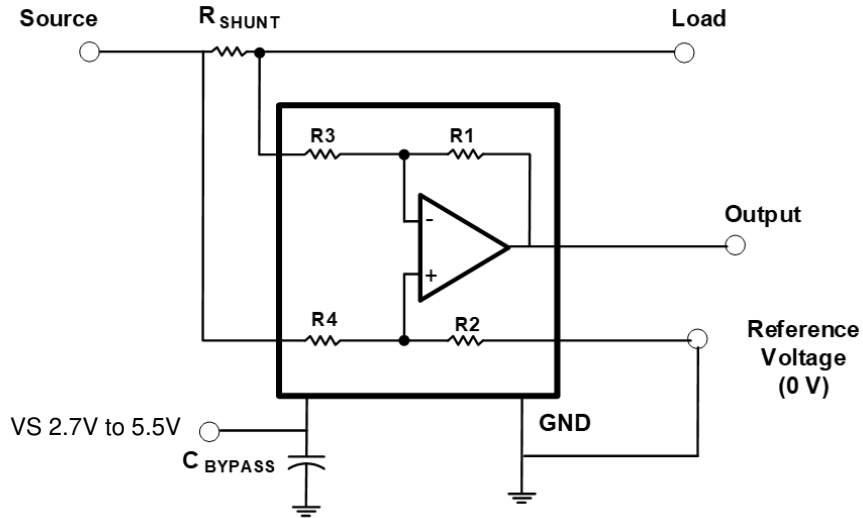

Figure 14. Single-Direction Application Schematic Using Ground as a Reference

An example output response of a single directional configuration is shown in Figure 15. With the REF pin connected directly to ground, the output voltage is biased to this zero-output level. The output rises above the reference voltage for positive differential input signals but cannot fall below the reference voltage for negative differential input signals because of the grounded reference voltage.

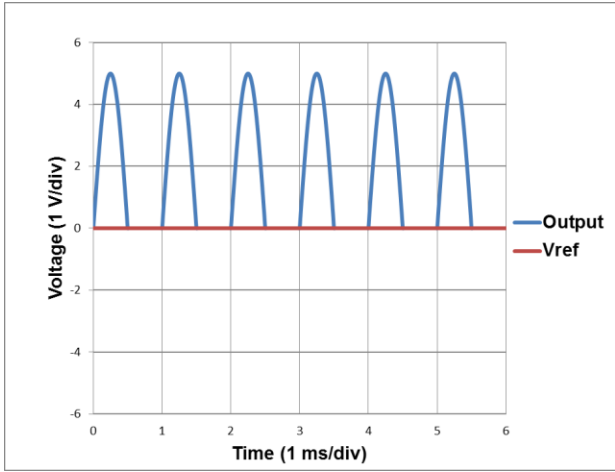

Figure 15. Single-Direction Application Output Response

**Application Information** (continued)

**Bi-Directional Operation**

The device is a bi-directional, current-sense amplifier capable of measuring currents through a resistive shunt in two directions. This bi-directional monitoring is common in applications that include charging and discharging operations where the current flow through the shunt resistor can change directions.

The ability to measure this current flowing in both directions is enabled by applying a voltage to the REF pin; see Figure 16. The voltage applied to REF ( $V_{REF}$ ) sets the output state that corresponds to the zero-input level state. The output then responds by increasing above  $V_{REF}$  for positive differential signals (relative to the IN- pin) and responds by decreasing below  $V_{REF}$  for negative differential signals. This reference voltage applied to the REF pin can be set anywhere between 0V to  $V_S$ . For bi-directional applications,  $V_{REF}$  is typically set at mid-scale for equal signal range in both current directions. In some cases, however,  $V_{REF}$  is set at a voltage other than mid-scale when the bi-directional current and corresponding output signal do not need to be symmetrical. In Figure 17, the REF pin has been set to 2.5V. Therefore, when the output of the ZXCT181Q is between zero and 2.5V, it represents a negative current through  $R_{SHUNT}$ . It is desirable to have an accurate low impedance voltage supply for the REF pin. A voltage reference or a resistor divider buffered with an op-amp are recommended. Any error that is introduced at the REF pin is added to the output voltage.

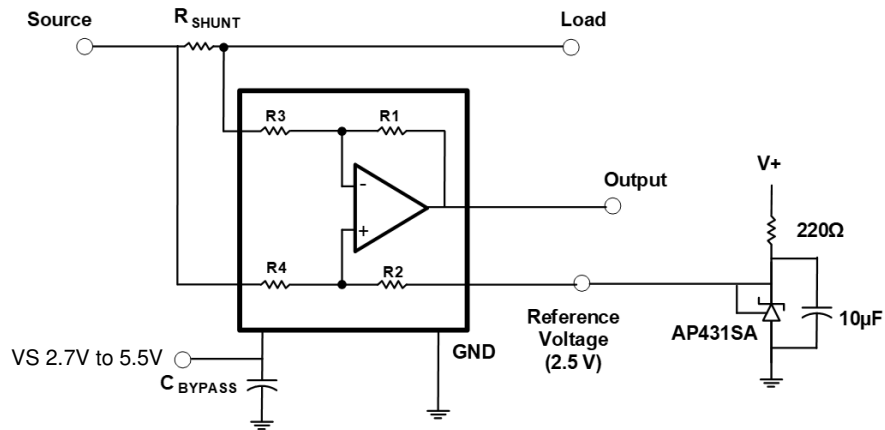

Figure 16. Bi-Directional Application Schematic Using 2.5V Reference

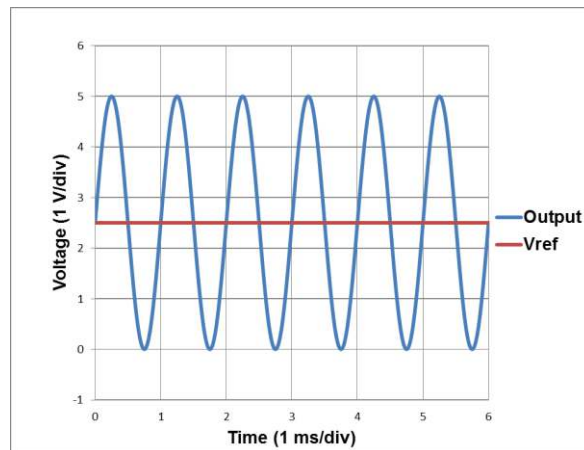
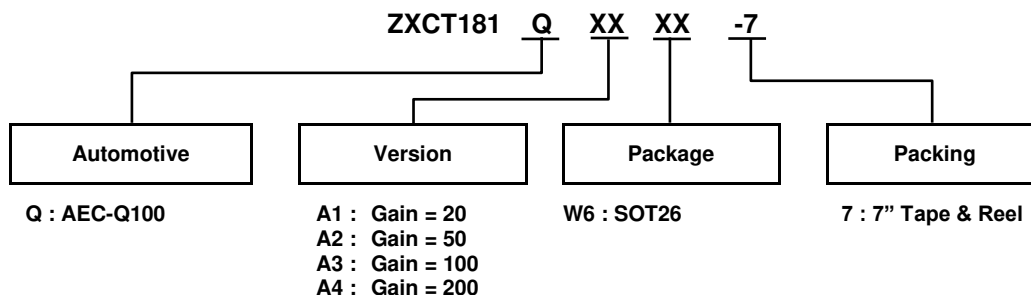

Figure 17. Bi-Directional Application Output Response

## Ordering Information



Orderable Part Number	Package Code	Package	Packing	
			Qty.	Carrier
ZXCT181QA1W6-7	W6	SOT26	3000	7" Tape & Reel
ZXCT181QA2W6-7	W6	SOT26	3000	7" Tape & Reel
ZXCT181QA3W6-7	W6	SOT26	3000	7" Tape & Reel
ZXCT181QA4W6-7	W6	SOT26	3000	7" Tape & Reel

## Marking Information

(Top View)

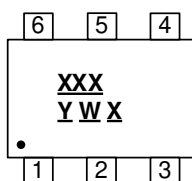

**XXX** : Identification Code  
**Y** : Year 0 to 9 (ex: 4 = 2024)  
**W** : Week : A to Z : week 1 to 26;  
a to z : week 27 to 52; z represents week 52 and 53  
**X** : Internal Code

Orderable Part Number	Package	Identification Code
ZXCT181QA1W6-7	SOT26	MJQ
ZXCT181QA2W6-7	SOT26	MKQ
ZXCT181QA3W6-7	SOT26	MMQ
ZXCT181QA4W6-7	SOT26	MNQ

## Package Outline Dimensions

Please see <http://www.diodes.com/package-outlines.html> for the latest version.

### SOT26

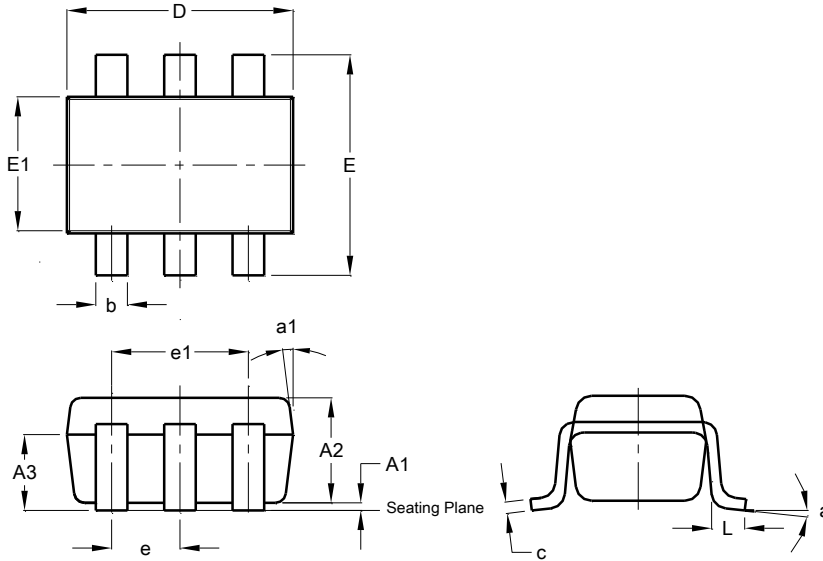

SOT26			
Dim	Min	Max	Typ
A1	0.013	0.10	0.05
A2	1.00	1.30	1.10
A3	0.70	0.80	0.75
b	0.35	0.50	0.38
c	0.10	0.20	0.15
D	2.90	3.10	3.00
e	-	-	0.95
e1	-	-	1.90
E	2.70	3.00	2.80
E1	1.50	1.70	1.60
L	0.35	0.55	0.40
a	-	-	8°
a1	-	-	7°
All Dimensions in mm			

## Suggested Pad Layout

Please see <http://www.diodes.com/package-outlines.html> for the latest version.

### SOT26

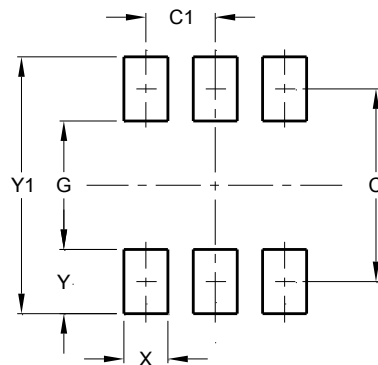

Dimensions	Value (in mm)
C	2.40
C1	0.95
G	1.60
X	0.55
Y	0.80
Y1	3.20

## Mechanical Data

### SOT26

- Moisture Sensitivity: Level 1 per J-STD-020
- Terminals: Finish – Matte Tin Plated Leads, Solderable per MIL-STD-202, Method 208 e3
- Weight: 0.016 grams (Approximate)
- Max Soldering Temperature +260°C for 30 secs as per JEDEC J-STD-020

**IMPORTANT NOTICE**

1. DIODES INCORPORATED (Diodes) AND ITS SUBSIDIARIES MAKE NO WARRANTY OF ANY KIND, EXPRESS OR IMPLIED, WITH REGARDS TO ANY INFORMATION CONTAINED IN THIS DOCUMENT, INCLUDING, BUT NOT LIMITED TO, THE IMPLIED WARRANTIES OF MERCHANTABILITY, FITNESS FOR A PARTICULAR PURPOSE OR NON-INFRINGEMENT OF THIRD PARTY INTELLECTUAL PROPERTY RIGHTS (AND THEIR EQUIVALENTS UNDER THE LAWS OF ANY JURISDICTION).
2. The Information contained herein is for informational purpose only and is provided only to illustrate the operation of Diodes' products described herein and application examples. Diodes does not assume any liability arising out of the application or use of this document or any product described herein. This document is intended for skilled and technically trained engineering customers and users who design with Diodes' products. Diodes' products may be used to facilitate safety-related applications; however, in all instances customers and users are responsible for (a) selecting the appropriate Diodes products for their applications, (b) evaluating the suitability of Diodes' products for their intended applications, (c) ensuring their applications, which incorporate Diodes' products, comply the applicable legal and regulatory requirements as well as safety and functional-safety related standards, and (d) ensuring they design with appropriate safeguards (including testing, validation, quality control techniques, redundancy, malfunction prevention, and appropriate treatment for aging degradation) to minimize the risks associated with their applications.
3. Diodes assumes no liability for any application-related information, support, assistance or feedback that may be provided by Diodes from time to time. Any customer or user of this document or products described herein will assume all risks and liabilities associated with such use, and will hold Diodes and all companies whose products are represented herein or on Diodes' websites, harmless against all damages and liabilities.
4. Products described herein may be covered by one or more United States, international or foreign patents and pending patent applications. Product names and markings noted herein may also be covered by one or more United States, international or foreign trademarks and trademark applications. Diodes does not convey any license under any of its intellectual property rights or the rights of any third parties (including third parties whose products and services may be described in this document or on Diodes' website) under this document.
5. Diodes' products are provided subject to Diodes' Standard Terms and Conditions of Sale (<https://www.diodes.com/about/company/terms-and-conditions/terms-and-conditions-of-sales/>) or other applicable terms. This document does not alter or expand the applicable warranties provided by Diodes. Diodes does not warrant or accept any liability whatsoever in respect of any products purchased through unauthorized sales channel.
6. Diodes' products and technology may not be used for or incorporated into any products or systems whose manufacture, use or sale is prohibited under any applicable laws and regulations. Should customers or users use Diodes' products in contravention of any applicable laws or regulations, or for any unintended or unauthorized application, customers and users will (a) be solely responsible for any damages, losses or penalties arising in connection therewith or as a result thereof, and (b) indemnify and hold Diodes and its representatives and agents harmless against any and all claims, damages, expenses, and attorney fees arising out of, directly or indirectly, any claim relating to any noncompliance with the applicable laws and regulations, as well as any unintended or unauthorized application.
7. While efforts have been made to ensure the information contained in this document is accurate, complete and current, it may contain technical inaccuracies, omissions and typographical errors. Diodes does not warrant that information contained in this document is error-free and Diodes is under no obligation to update or otherwise correct this information. Notwithstanding the foregoing, Diodes reserves the right to make modifications, enhancements, improvements, corrections or other changes without further notice to this document and any product described herein. This document is written in English but may be translated into multiple languages for reference. Only the English version of this document is the final and determinative format released by Diodes.
8. Any unauthorized copying, modification, distribution, transmission, display or other use of this document (or any portion hereof) is prohibited. Diodes assumes no responsibility for any losses incurred by the customers or users or any third parties arising from any such unauthorized use.
9. This Notice may be periodically updated with the most recent version available at <https://www.diodes.com/about/company/terms-and-conditions/important-notice>

The Diodes logo is a registered trademark of Diodes Incorporated in the United States and other countries.  
All other trademarks are the property of their respective owners.  
© 2024 Diodes Incorporated. All Rights Reserved.

[www.diodes.com](http://www.diodes.com)