

APX-XNG0031PSD

2mm Diameter Extended Visible InGaAs Position Sensitive Detector (PSD)

The APX-VNG0031PSD series are tetra-lateral 2mm diameter active area EXTENDED VISIBLE InGaAs position sensitive detectors. These high-accuracy position detection devices feature an enhanced sensitivity spectrum from 450nm to 1700nm, surpassing the standard InGaAs spectral response of 700nm to 1700nm. The devices are available in two inter-electrode resistance options of 0.5k Ω and 2.2k Ω . They are also available in a hermetically sealed TO-5 metal can or a Leadless Chip carrier (LCC) package.

Applications

Alignment

Position Sensing

Industrial Sensing

Guidance Systems

Targeting

Communication

Features

High Position Detection Accuracy

0.5k Ω or 2.2k Ω Inter-Electrode

Resistance

450-1700 nm sensitivity

High Shunt Resistance

TO-5 or Leadless Chip Carrier (LCC)

2mm Diameter Active Area

Absolute Maximum Ratings at $T_A=23\text{ }^\circ\text{C}$

Parameter	Symbol	APX-XNG0031PSD-001		APX-XNG0031PSD-002		APX-XNG0031PSD-003		APX-XNG0031PSD-004		Unit
		Min	Max	Min	Max	Min	Max	Min	Max	
Reverse Voltage	V_R	-	4	-	4	-	4	-	4	V
Operating Temperature	T_{OP}	-40	+125	-40	+125	-40	+125	-40	+125	$^\circ\text{C}$
Storage Temperature	T_{STG}	-55	+125	-55	+125	-55	+125	-55	+125	$^\circ\text{C}$
Package		TO-5		TO-5		Ceramic LCC		Ceramic LCC		

Typical Electro-Optical Specifications at $T_A=23\text{ }^\circ\text{C}$

Parameter	Test Conditions		APX-XNG0031PSD-001			APX-XNG0031PSD-002			APX-XNG0031PSD-003			APX-XNG0031PSD-004			Unit
			Min	Typ	Max	Min	Typ	Max	Min	Typ	Max	Min	Typ	Max	
Active Area	-	A.A.	-	3.1	-	-	-	-	-	3.1	-	-	3.1	-	mm^2
Active Area Diameter	-	A.A. $_{\phi}$	-	2	-	-	2	-	-	2	-	-	2	-	mm
Spectral range	Spot Scan	$\Delta\lambda$	450	-	1700	450	-	1700	450	-	1700	450	-	1700	nm
Reponsivity	$\lambda=632\text{nm}$	R_{λ}	0.25	0.29	-	0.25	0.29	-	0.25	0.29	-	0.25	0.29	-	A/W
	$\lambda=1060\text{nm}$	R_{λ}	0.69	0.73	-	0.69	0.73	-	0.69	0.73	-	0.69	0.73	-	A/W
	$\lambda=1550\text{nm}$	R_{λ}	0.90	1.06	-	0.90	1.06	-	0.90	1.06	-	0.90	1.06	-	A/W
Capacitance	$V_R=0\text{V}$; $f=1\text{MHz}$	C_J	-	250	350	-	250	350	-	250	350	-	250	350	pF
	$V_R=4\text{V}$; $f=1\text{MHz}$	C_J	-	130	200	-	130	200	-	130	200	-	130	200	pF
Dark Current	$V_R=1\text{V}$	I_D	-	5	20	-	5	20	-	5	20	-	5	20	nA
	$V_R=4\text{V}$	I_D	-	30	150	-	30	150	-	30	150	-	30	150	nA
Shunt Resistance	$V_R=10\text{mV}$	R_{SH}	2	20	-	5	20	-	2	20	-	5	20	-	$\text{M}\Omega$
Inter-Electrode Resistance ²	Between diagonally opposing contacts	-	-	2.2	-	-	0.5	-	-	2.2	-	-	0.5	-	$\text{k}\Omega$
Position Detection Error	$V_R=1\text{V}$	PDE	-	20	-	-	20	-	-	20	-	-	20	-	μm

Typical Spectral Response

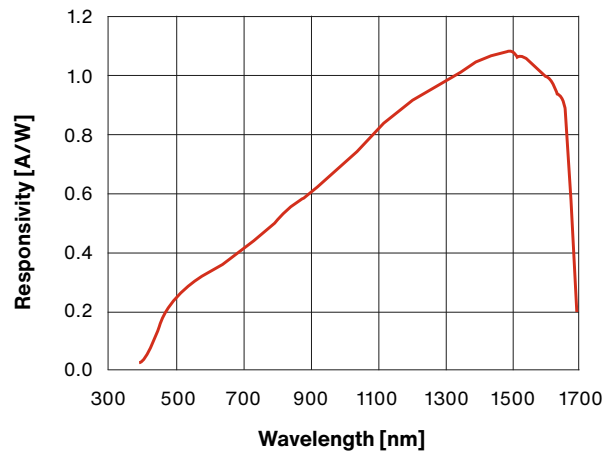

Position Error Scan

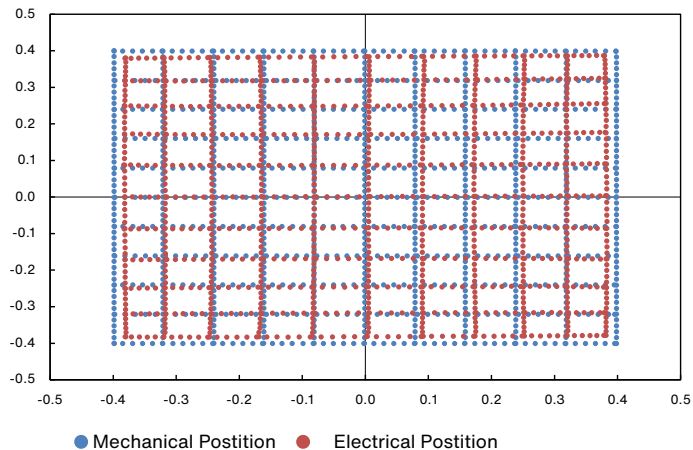

Mechanical Specification

Units are in inches [mm]

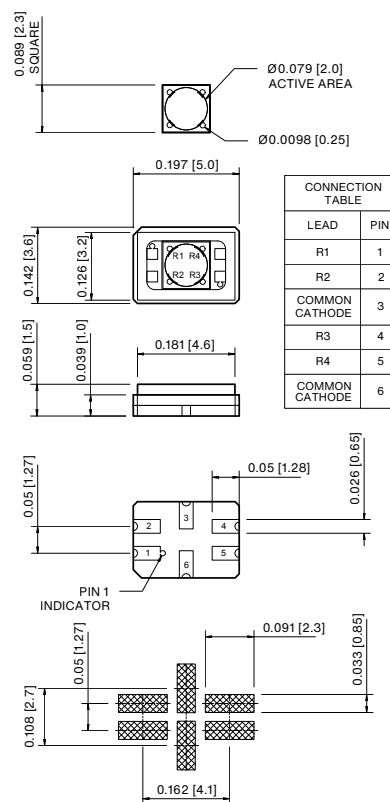
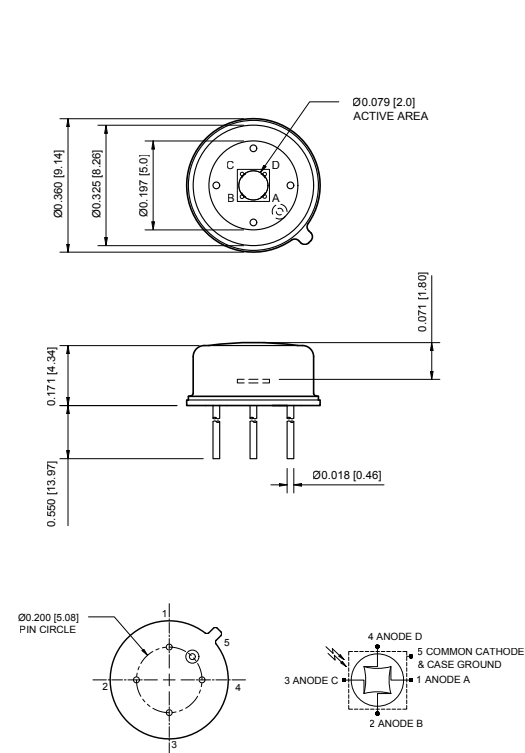

APX-XNG00031PSD-001/002

APX-XNG0031PSD-003/004

General Care and Handling Instructions

Photodiodes:

Handling and Storage

- Handle Photodiodes gently to prevent damage.
- Avoid exposing Photodiodes to temperatures exceeding the storage temperature rating of the device.
- Maintain a non-condensing environment for optimum performance and lifetime.

Cleaning

- Gently clean the glass (borosilicate or quartz window) using a 50/50 mixture of Methanol and isopropyl alcohol and a soft, optical-grade pad.

Special Considerations for Plastic or Epoxy Encapsulated Photodiodes

- Protect from intense light sources such as direct sunlight.
- Avoid exposure to harsh chemicals like THINNERS, ACETONE, and TRICHLOROETHYLENE.
- Cleaning with a 50/50 mixture of Methanol and isopropyl alcohol (IPA) is recommended. Cleaning in an ultrasonic bath is generally not recommended.

CdS Photocells:

Handling and Storage

- Handle CdS Photocells gently to prevent damage.
- Avoid exposing CdS Photocells to temperatures exceeding the storage temperature rating of the device.
- Maintain a non-condensing environment for optimum performance and lifetime.

Cleaning

- Gently clean the glass or plastic covering using a 50/50 mixture of Methanol and isopropyl alcohol and a soft, optical-grade pad.

Special Considerations

- DO NOT use Vapor Phase Soldering or Reflow Soldering for CdS components.

Optocouplers and LEDs:

Handling and Storage

- Handle Optocouplers and LEDs gently to prevent damage.
- Avoid exposing the devices to temperatures exceeding the storage temperature rating of the device.
- Maintain a non-condensing environment for optimum performance and lifetime.

Cleaning

- For plastic molded devices, cleaning with a 50/50 mixture of Methanol and isopropyl alcohol is recommended. Cleaning in an ultrasonic bath is generally not recommended.

Special Considerations

- Avoid exposing plastic molded devices or epoxy glob top devices to harsh chemicals like THINNERS, ACETONE, and TRICHLOROETHYLENE.

Electrostatic Discharge (ESD) Sensitivity:

- All devices are considered ESD-sensitive. They are shipped in ESD protective packaging. When unpacking and using these products, anti-ESD precautions should be observed.

Lead Trimming and Bending:

- Standard lead trimming after soldering is an acceptable practice; however, do not attempt to bend or modify the leads incorrectly, as it can damage the glass feed-through or the plastic encapsulant.

Soldering Instructions:

- Use a soldering iron with a tip temperature of 300°C max.
- Consult with your preferred solder manufacturer to determine a solder alloy and flux combination, as well as the reflow profile appropriate for your application.

General Precautions for all Devices

1. Moisture Prevention:

Ensure devices are stored in a dry environment to prevent moisture ingress, which can cause damage during soldering. Refer to J-STD-20 for guidance on proper baking procedures to prevent moisture related damage.

2. Lead Splaying:

If required, carefully splay the leads of the devices according to the specific application needs. Be cautious when splaying leads, as improper techniques may damage the device. Consult technical support or device datasheets for guidance on lead splaying.

3. Mechanical Stress:

Handle devices with care throughout the installation process to prevent damage.

4. Circuit Protection and Layout:

Optimize the circuit design and layout to ensure proper functioning and prevent damage to the devices. Include appropriate protection measures like ESD protection diodes, current-limiting resistors, and voltage regulation.

5. After-Sale Support:

For troubleshooting and device-specific inquiries, please consult with our technical support team. They can offer valuable guidance and suggestions on handling, operation, and application-related questions. To reach them, please contact the Advanced Photonix Applications group at Techsupport@advancedphotonix.com.

Legal Disclaimer

Information in this data sheet is believed to be correct and reliable. However, no responsibility is assumed for possible inaccuracies or omission. Specifications are subject to change without notice.

